

EM/409031

Report on
Visit to John Bedini

With Comments by Tom Bearden
And Additional Experiments by Eike Mueller

3 September 1984

By: Eike Mueller

FOREWORD

Following an invitation by John Bedini, I went with him to Los Angeles immediately after the Colorado Springs Tesla Symposium on 10-12 August 1984. We had two days together to work on the Kromrey Converter and the Tesla Switching Device.

One thing came out very clearly: every time when we locked into the "free energy" all commonly known physical laws are no longer valid. The things happening react directly opposite to what one would expect. Specifically the more we loaded a specific circuit, the more output energy we gained, while using a constant input energy level. I will come back to this effect later, when I describe the experiments in more details.

At this point I want to take the opportunity and thank John Bedini and his lovely wife for their hospitality and assistance. It takes persons like John to get the "free energy" rolling. Without his publication [1] of the detailed plans for his free energy device, we would definitely not have seen the free energy devices demonstrated during the Tesla Symposium.

Also many thanks to Tom Bearden, who took his time and explained the results of the tests performed on 13-14 August 1984. His comments are contained in the concluding chapter of this report.

Kromrey Converter

John Bedini found that the material generally available concerning Kromrey's Converter had been altered. Rebuilding the Kromrey Converter from the patent papers ended up in a non-functioning device. Bedini found the necessary modifications which made this machine perform.

Our first goal was to determine the converter's efficiency. We found this to be quite difficult as the efficiency changes with the load applied.

FIGURE K-1 shows the first setup we used. We drove the Kromrey Converter from a 12 V motorcycle battery. We connected at the output of the converter a condenser and a rectifier bridge in parallel. The rectified current was then put back into the motorcycle battery. To detect any current flow, we connect into the positive line a 12 V light bulb.

The result of this test was that the light bulb was lit up. However, after 15 minutes the battery voltage had dropped from 11.05 V to 9.10 V. The speed of the converter was stable at 1020 rpm.

[1] "Bedini's Free Energy Generator" by John Bedini, Tesla Book Company, Millbrae, California 1984

BEDINI, MUELLER 13 AUGUST 84 TEST # 1

KROMREY DEVICE

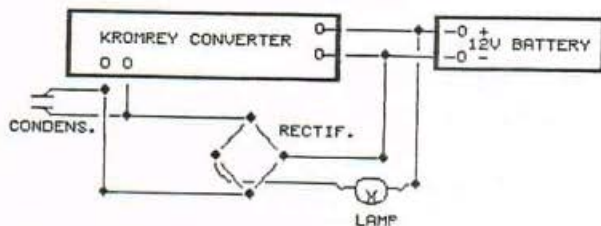

SPEED OF CONVERTER: 17 RPS.

VOLTAGE AT BEGINNING: 11.05 V AFTER 15 MINUTES: 9.10 V

FIGURE K-1
KROMREY CONVERTER
TEST SETUP

In the next test we introduced a separate battery (BATTERY #2) for charging from the converter.

We recharged the battery #2 from 12.30 V to 12.40 V within 4 minutes, and we measured a current into battery #2 of 0.8 amperes.

BEDINI, MUELLER 13 AUGUST 84 TEST # 2

KROMREY DEVICE

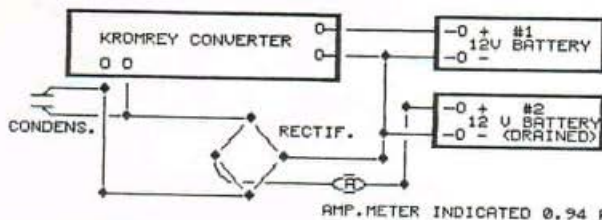

AMP. METER INDICATED 0.94 A

CHARGING OF BATTERY #2 VIA KROMREY CONVERTER AND BATTERY #1
VOLTAGE BATT. #2: 12.35 V, AND AFTER 4 MINUTES: 12.40 V

FIGURE K-2
KROMREY CONVERTER
SETUP 2

PICTURE C-1.1 shows the second test setup. On the left side is the Kromrey Converter, powered by an electric motor (center). Battery #2 is the battery in the front (center right) and battery #1 is the one behind it. The voltmeter shows the voltage of battery #2. The 12 V light bulb is on the table in front of battery #2.

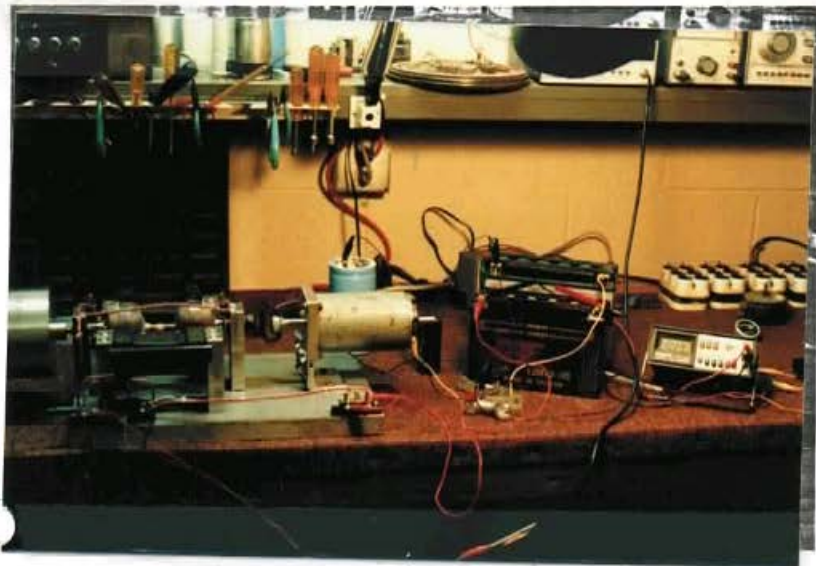

PICTURE C-1.1
KROMREY CONVERTER
SECOND TEST SETUP

Because the Kromrey Converter turned too slow on one 12 V battery, we decided to drive the Converter using 24 V via two 12 V batteries, connected in series. PICTURE C-1.2 shows this setup.



PICTURE C-1.2

Next we wanted to find a correlation between the normal charging of battery #2 using a commercial battery charger, and charging this same battery with the Kromrey Converter. We drained the battery #2 to 8 V, connected it to the Kromrey Converter, and after reaching 11.51 V, we measured the time it took to charge the battery from this voltage level of 11.51 V to 12.45 V. We reached this voltage (12.45 V) after 11 minutes. The indicated current into the battery was 0.94 A.

We then repeated these steps using the commercial battery charger. Because we ran out of time after nearly 2 hours, we disconnected the battery from the charger. The battery voltage had reached 12.41 V. The measurement is depicted in FIGURE K-3.

BEDINI, MUELLER 13 AUGUST 84 TEST # 3

KROMREY DEVICE

COMPARISON MEASUREMENT USING A
CONVENTIONAL BATTERY CHARGER

FIGURE K-3

BATTERY #2 VOLTAGE: 11.51 V

AFTER 119 MINUTES: 12.41 V

CHARGING CURRENT AT BEGINNING: 0.60 A; AT THE END: 0.37 A

NOTE: HE DID NOT REACH 12.45 V EVEN AFTER 2 HOURS.

We wanted to find the correction factor for the Kromrey Converter by comparing the same effect, i.e. the charging of the same battery from one specific voltage to another specific voltage. The calculation of this factor is shown in FIGURE K-4. This correction factor C_K was determined by dividing the area Y (amperes over time, for charging with the commercial battery charger) through area X (amperes over time, Kromrey).

BEDINI, MUELLER 13 AUGUST 84 TESTS # 2 + 3

KROMREY DEVICE

DETERMINATION OF CORRECTION FACTOR

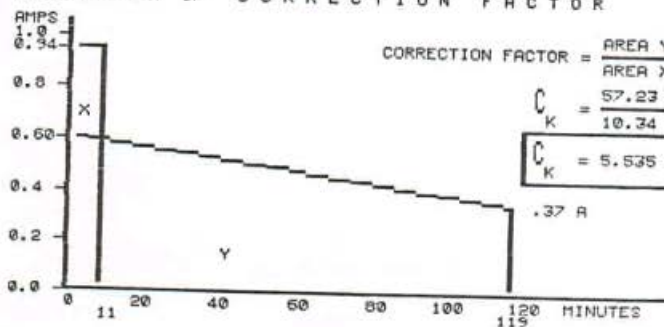

FIGURE K-4

TABLE K-1 shows the combined test results. Because we detected an increase in the speed of the Kromrey Converter as well as a decrease in the input energy when we increased the output load, we decided to measure the input energy and speed when the output was shorted. Again, the input energy dropped and the speed increased.

MEASUREMENT	NO LOAD	LOADED WITH BATTERY	SHORTED	CORRECTED FACT. 5.535
- INPUT VOLTAGE	25.30	25.00	24.90	
- INPUT CURRENT	3.90	3.00	2.20	
WATTS IN	98.67	75.00	54.78	
- SPEED IN REV/SECOND	40.00	65.00	73.00	
- OUTPUT VOLTAGE (DC)	48.00	10.80	N/A	
- OUTPUT CURRENT	N/A	0.95	1.05	
WATTS OUT	N/A	10.26	N/A	56.78
WATTS IN/OUT		7.31		1.32

TABLE K-1

Using the earlier determined correction factor of 5.535 we calculated the energy we put into the battery to 56.78 Watts (from 10.26 * 5.535). Looking at TABLE K-1 we see that it takes only 54.78 Watts to run the Kromrey Converter when the output is shorted. This result led us to continue with these tests and load the converter output even more. The results of these tests can be seen in TABLE K-2 on the next page.

Here again, we detected that we will get a higher efficiency of the total device, the more we load down the output side. This effect is totally contradictory to the conventional laws of physics.

MEASUREMENT	NO LOAD	LOADED WITH LAMP & BATT.	LOADED WITH RESISTOR 13.5 OHM	LOADED WITH RESISTOR 0.63 OHM
- INPUT VOLTAGE	25.40	25.30	20.00	21.90
- INPUT CURRENT	3.90	3.90	3.39	2.30
WATTS IN	99.06	98.67	67.80	50.37
- OUTPUT VOLTAGE (DC)	48.00	28.00	50.00	20.00
- OUTPUT CURRENT	N/A	0.75		
- RESISTANCE (OHM)			13.50	0.63
WATTS OUT	N/A	21.00	185.19	634.92
WATTS OUT (CORRECTED)		116.24		
WATTS IN/OUT		0.85	0.37	0.08

TABLE K-2

We used the Kromrey correction factor for the first case, when we had connected the battery to the converter output. We did not use this factor in both other cases when we used resistors in the output circuit.

These above test results show that the efficiency of the Kromrey Converter is well above 100%.

The Tesla Switch

We used as a starting point for our experiments, the switching device John Bedini had built for the Tesla Symposium (FIGURE T-1). Our goal was to upgrade this switching device for ordinary car or motorcycle batteries.

To get a better understanding of this system, we first built only one half of the circuit. FIGURE T-2 shows our first arrangement.

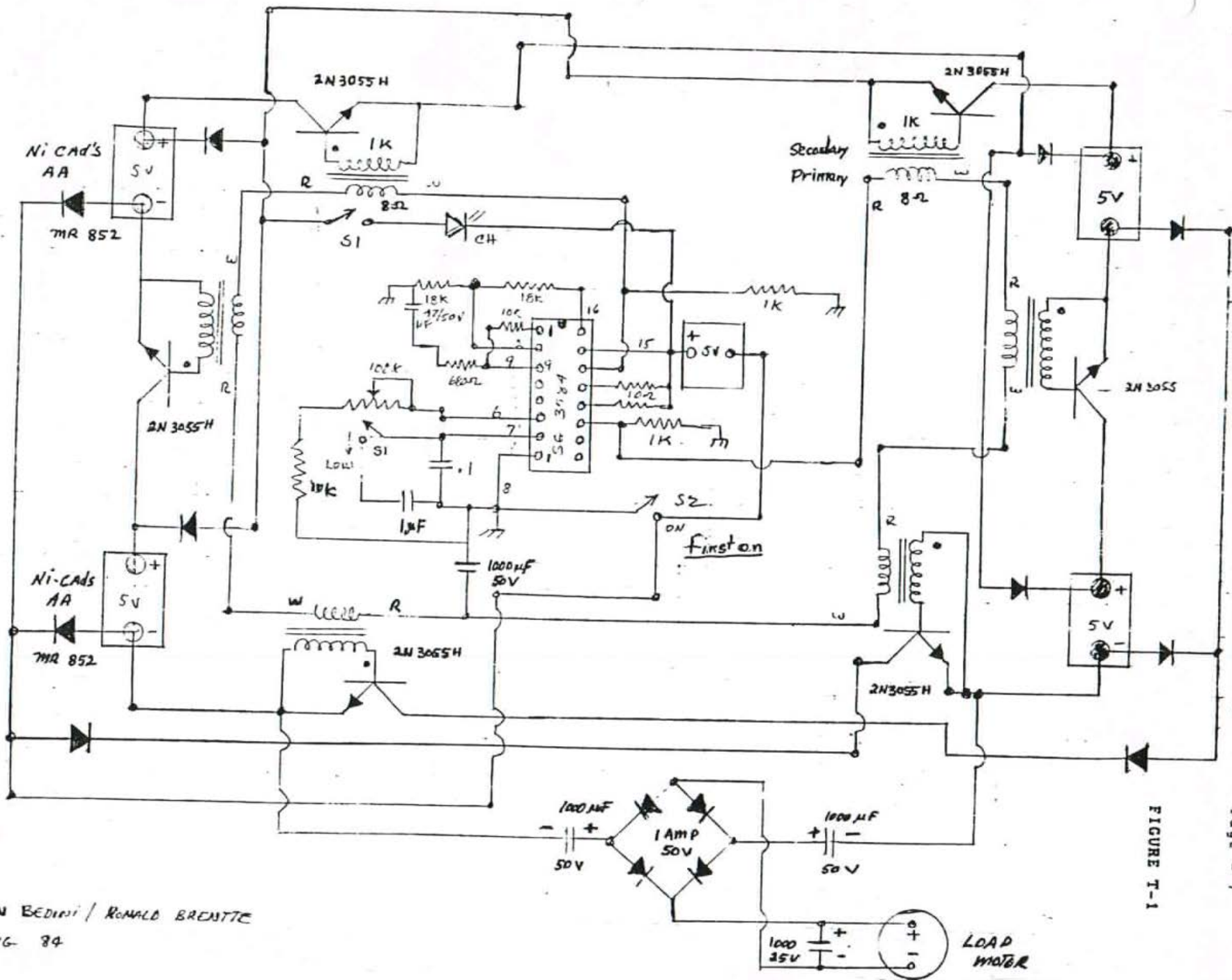

JOHN BEDINI / RONALD BRENTTE
AUG 84

FIGURE T-1

BEDINI, MUELLER

13 AUGUST 84

TEST # 11A

TESLA SWITCH

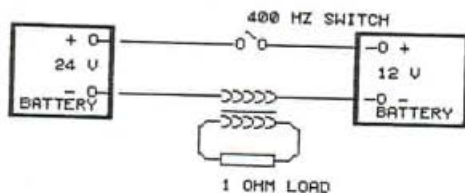

FIGURE T-2

TO RAISE THE VOLTAGE FROM 11.51 V TO 12.45 V TOOK 5 SEC.
 COMPARE THIS RESULT WITH TESTS # 3 AND 5. FIG. K-4
 NOTE: 1 OHM RESISTOR REMAINED COLD AFTER 15 MIN. RUN TIME.

Using the setup shown in FIGURE T-3, we performed the same kind of test we did earlier, using the Kromrey Converter. This time we used a 12 V battery with one dead cell as if it were a 10 Volt battery (dead cell not in the loop). The supplying battery was a freshly charged 12 V battery.

In the first step we drained the 10 V battery. When we connected this battery to the conventional battery charger it showed a voltage of 1.7 Volts. After 12 minutes 20 seconds we had reached a voltage level of 10.24 Volts.

Again, we drained the battery and then connected it to the Tesla Switch. After 1 minute and 24 seconds we had reached 10.24 Volts. We detected that the temperature of the battery was higher than it was before, when we had used the conventional battery charger.

BEDINI, MUELLER

13 AUGUST 84

TEST # 11B

TESLA SWITCH

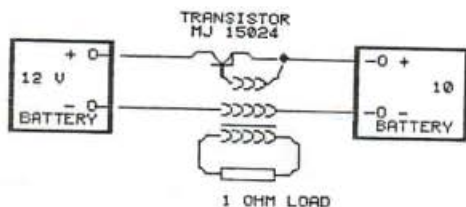

FIGURE T-3

TO RAISE THE VOLTAGE FROM 1.7 V TO 10.24 V TOOK 1 MIN 5 SEC.
 NOTE: 1 OHM RESISTOR REMAINED COLD AFTER 15 MIN. RUN TIME.

Because we had already learned that the efficiency will go up the more we load the circuit (see TABLE K-2), we decided to load this Tesla circuit also. We modified our test setup slightly by introducing amperemeters and two light bulbs. A 110 V, 40 W bulb was used on the secondary side of the transformer, and a 12 V, 280 W quartz lamp was connected in parallel with the 10 V battery. FIGURE T-4 shows the arrangement and the currents we measured. Again, we found that when we connected the quartz lamp, the 110 V light instantaneously became brighter.

BEDINI, MUELLER

17 AUGUST 84

TEST # 12

TESLA SWITCH

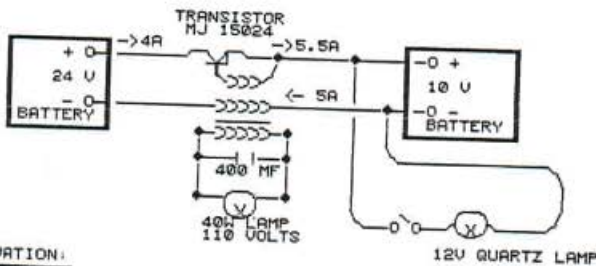

FIGURE T-4

OBSERVATION:

WHEN 12V QUARTZ LAMP WAS ADDED, THE 40W LAMP BECAME BRIGHTER

FIGURE C-2.1 shows this experiment. The quartz lamp is on top of the 10 V battery and the 110 V light bulb is in front of the transformer.

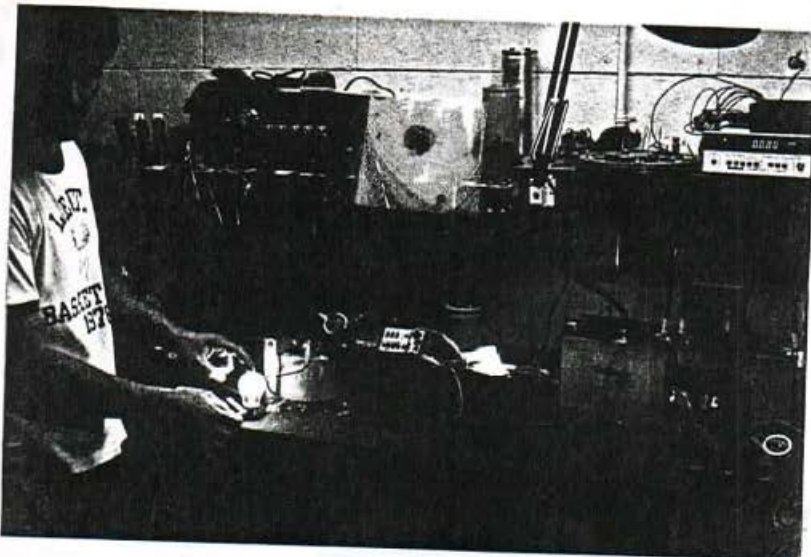

FIGURE C-2.1

When we compare all the measured values we get the following table:

CURRENT FLOW FROM THE 24 V BATTERY:	4.0 A AT 24.0 V	--->	96 WATTS
CURRENT FLOW INTO 10 V BATTERY:	5.5 A AT 10.6 V	--->	58 WATTS
INTO QUARTZ LAMP:	30.0 A AT 9.0 V	--->	270 WATTS
40 WATTS 110 V LIGHT BULB:		--->	40 WATTS

$$\text{WATTS IN/OUT} = 96/368 = 0.26$$

Every time when we disconnected and connected the 110 V light bulb in the setup as shown in FIGURE T-4 we saw a spark about a half-inch long. The light of this spark was noticeably different from the light of sparks observed when experimenting with high voltages. PICTURE C-3 shows such a spark. We discovered that in addition to X-rays we were also generating scalar waves. These were detected using a scalar wave detector built by John Bedini, which was based on a plan by Tom Bearden.

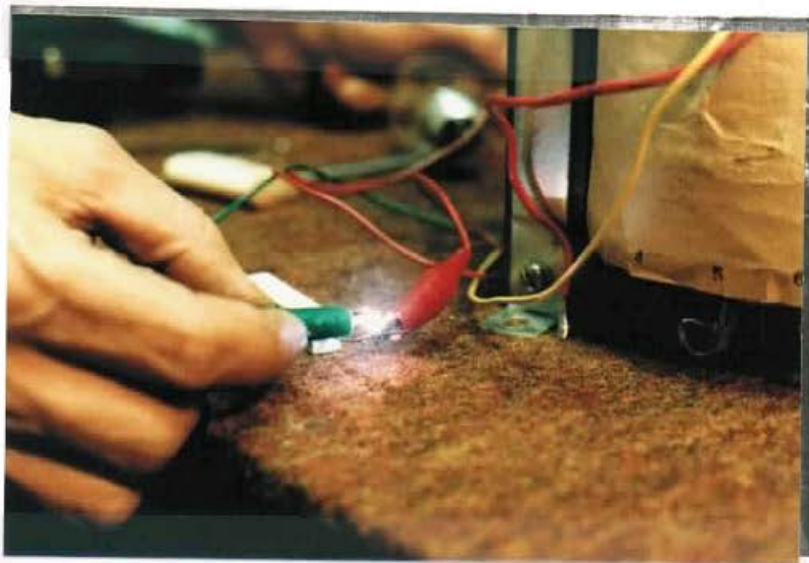

PICTURE C-3

Simplified Diagrams

At the end of this report I now show two simplified switching diagrams. These have been modified from the original diagram of Mr. Ronald Brentte which was given to John Bedini, Ken Moore and I updated the original diagram to make it more understandable to the layman.

BEDINI, BRENTTE, MUELLER 23 AUGUST 1984 PICTURE 5
TESLA SWITCH SAME NUMBERS USED AS IN ORIGINAL

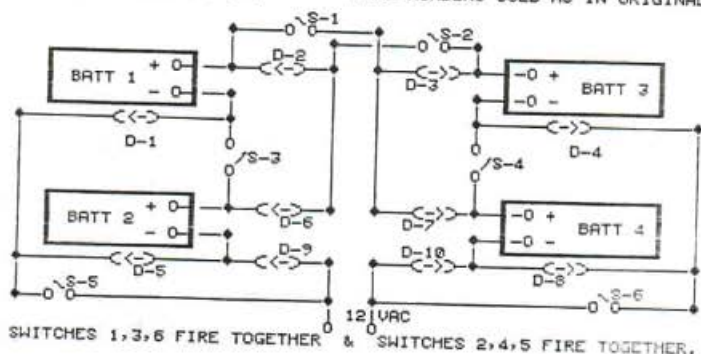

FIGURE T-5
 Original Diagram of
 Mr. Ronald Brentte

FIGURE T-6 shows how a circuit can work using three double-pole relay switches driven by a pulse rate generator (Ken Moore).

BEDINI, MUELLER, MOORE 23 AUGUST 1984 PICTURE 3
TESLA SWITCH - SIMPLIFIED DIAGRAM

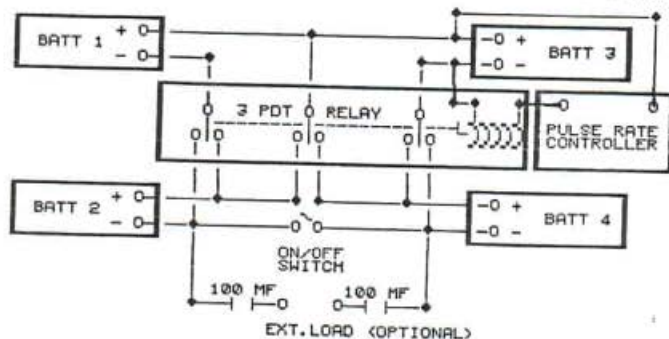
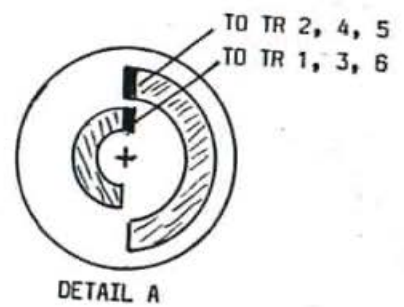
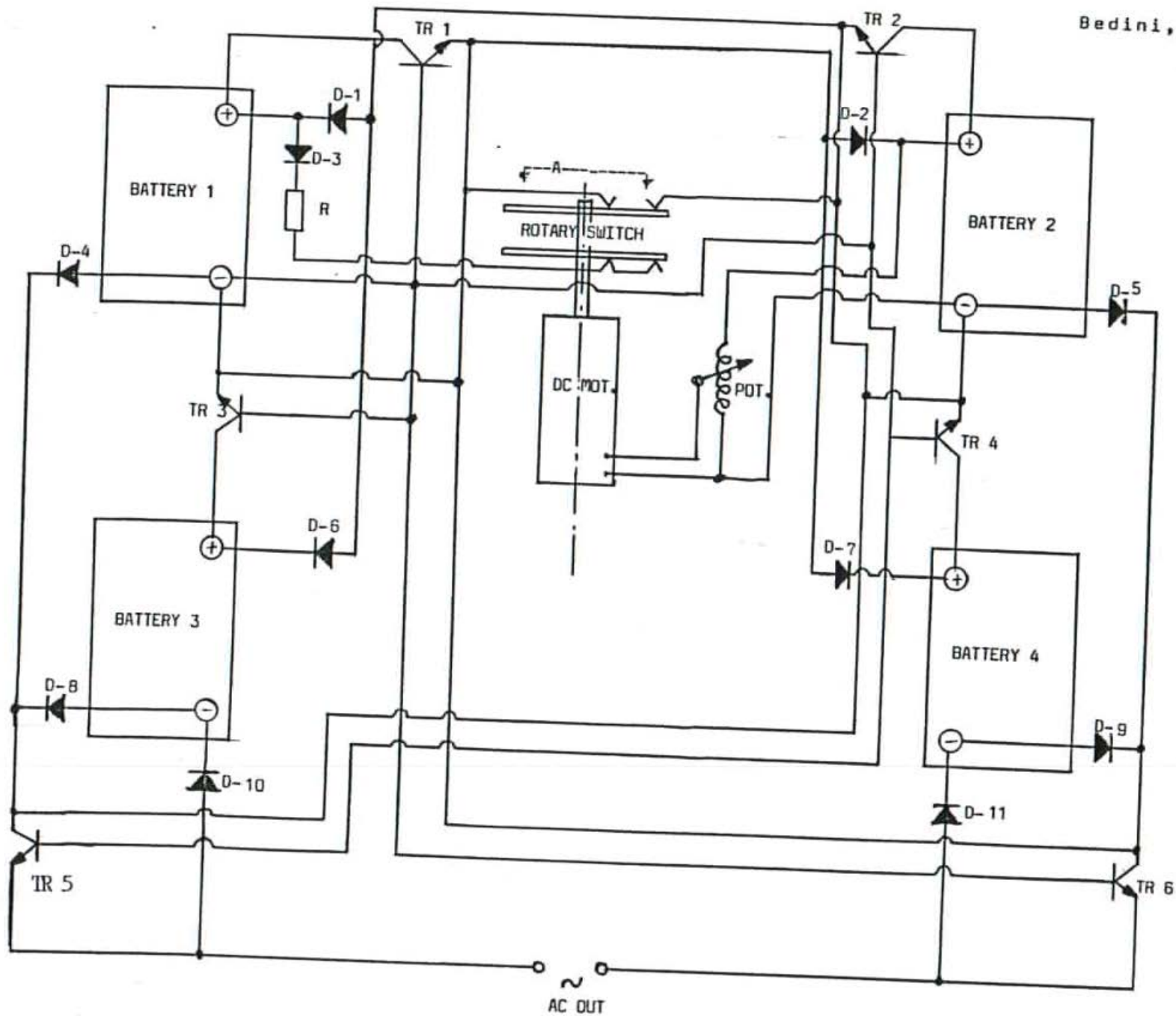

FIGURE T-6

FIGURE T-7 shows the circuit diagram for a setup using MJ 15024 power transistors driven by a rotary switch device.

TESLA SWITCHING DEVICE

Bedini, Brentte, Mueller



Eike Mueller VISIT TO JOHN BEDINI 13/14 AUG. 84

FIGURE T-7

COMMENTS BY TOM BEARDEN

- The Observation/Detection Process -

From the standpoint of modern physics, the "universe" we detect, measure, and see is always the "output" of an interaction between the detector/observer and "that unobserved reality" that is really there before the interaction. The "basic reality, before observation/detection" is comprised of something referred to as "action," having the units of angular momentum. That is, unobserved reality is composed of "energy multiplied by time," or "momentum multiplied by length," or the product of two other "locked together" (canonical) variables.

The best way to visualize a photon -- the basic electromagnetic quantum -- is to think of it as "a little piece of energy welded to a little piece of time," with no seam in the middle. In other words, the photon is a sort of "fusion of energy and time, without separation in any fashion." When we speak of "energy," ultimately we speak of photon exchange, whether the photons are "virtual" (smaller than can be individually detected) or observable (large enough to be individually detected).

Even with the macroscopic mechanical interactions, ultimately the forces are generated not by colliding objects but by exchange of virtual photons, in the view of modern quantum physics.

At any rate, when we make a "detection," the smallest amount of change involved in the unobservable universe is one "quantum" of action. However, we do not actually detect a whole quantum: instead we detect one piece of the quantum and lose the other piece. In other words, if we detect all the little piece of energy in the quantum, we lose all the little piece of time. If we detect a little piece of momentum, we lose all the little piece of length. The point is, one can imagine that we "split" or "fission" the quantum when we "detect", and we only detect one part of it. FIGURE 1 shows the operation of the detection process. Specifically, according to quantum mechanics we can never directly detect or observe the piece of "time" at all. Time is not observable, even in principle, in quantum mechanics.

In my first crude paper along these lines [1], I pointed out that quanta do not superpose; instead, a single quantum change occurs at a time, and a single detection occurs at a time. In conceptually modeling the fundamental detector itself, it was necessary to utilize a "fusion" process on the fragments of the quantum resulting from the fission/detection process. In other words, one has to clear out the residue before another "fragmenting" can occur. The way this happens is that the two pieces are fused together, back into a full quantum, disappearing into the basic action continuum.

Thus the passage through time of a body occurs in little time jumps. (FIGURE 2). And each little piece of time helping to make an individual jump is removed before the next jump occurs. That is, our march through time is not at all through a continuous time dimension as

Minkowski spacetime and relativity model it. Instead, we march through time like a peculiar sewing machine, one stitch at a time, and each stitch made is removed before the next one is made. This explains precisely why we cannot "see through time" as we see along the physical dimension. The time dimension is continually fragmented and destroyed.

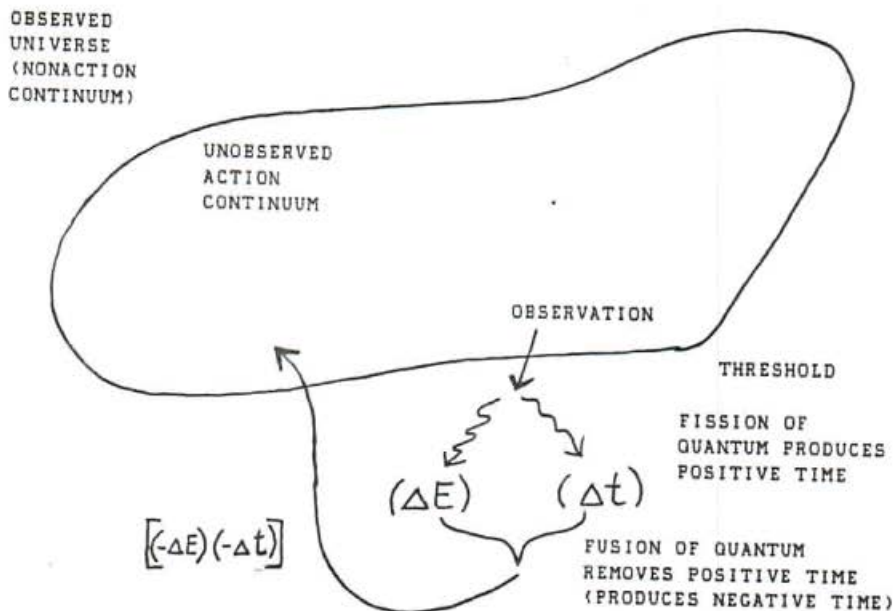

FIGURE 1. The Operation of Physical Detection at the Quantum Level.

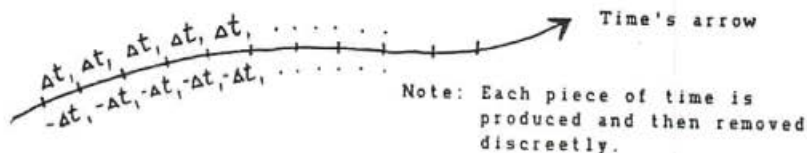

FIGURE 2. Passage of Object Through Time Occurs in Discrete Jumps

FIGURES 1 and 2 show the situation. Note that we can consider the "successive ripping out of time stitches" as the negative stream of time.

In this model, everything exists in both positive and negative time streams that usually are balanced. In this fashion, a completely new definition of mass was obtained, Newton's laws of motion (relativistic form) were derived, and the square law of gravitation was derived, albeit crudely. [2]

Now notice that, when an action quantum is split into conceivable energy and time, it may be split in two ways: a) it can be split into positive pieces of energy and positive pieces of time, or b) it can be split into a negative piece of energy and a negative piece of time. FIGURE 3 shows these possibilities of splitting. Note that, if we consider both the fission and fusion processes, both splits actually occur, depending upon which time stream one chooses to observe from.

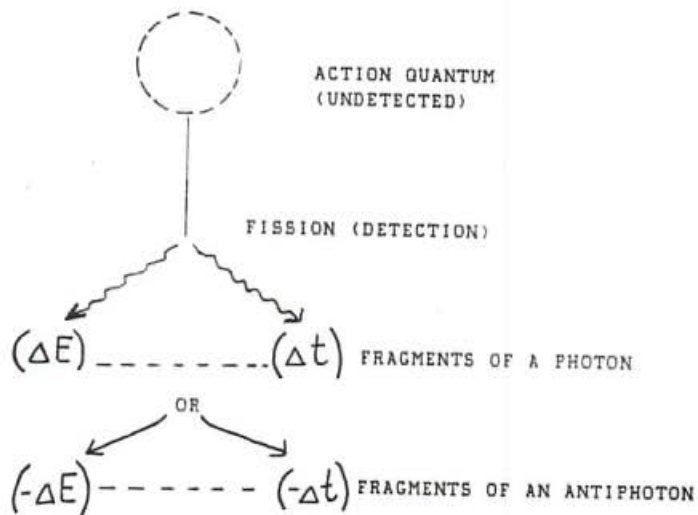

FIGURE 3. Two Possibilities of Action Quantum Fissioning

This is most interesting. We now have a concept whereby each object is passing through both the negative time flow and the positive time flow in an interweaved manner; to the microscopic observer, this appears to be simultaneously.

So an object may be said to possess both positive and negative energy, simultaneously, as a first order approximation. It possesses positive energy in positive time, and negative energies in negative time. In all normal processes, we have considered and developed only positive time processes. However, we point out that negative time operation is well-known in modern physics. Feynman diagrams involve extensive negative time travel. Originally Dirac did not predict the positron as a positive particle travelling forwards in positive time. Instead, he predicted a negative particle (traveling in negative time, in our

view), which we could only observe (with positive time instruments!) as a positive particle traveling forwards in time. In the view of modern physics, real particles already travel backwards in time sometimes.

But if we can actually produce some extra negative time in a device which normally is observed only to produce positive time, we shall obtain a reversal of entropy. Systems which tend to disorder in positive time, tend to order in negative time. Such an effect (production of negative time) involves the concomitant production of negative energy. However, negative electromagnetic energy will still run motors and burn light bulbs. The photon, you see, is its own antiparticle: and an antiphoton is just observed as another photon.

We will choose to regard an antiphoton as consisting of negative energy and negative time, and producing these two fragments if detected in the laboratory frame. The production of antiphotons and negative time will yield negentropy and additional or "free" negative energy, appearing to us to violate the ordinary "conservation of energy" law. This is no problem; production of unbalanced time streams, and hence the appearance of negative energy and negative time, is itself a "curved spacetime" phenomenon. Any system exhibiting this effect is existing in a locally curved spacetime (FIGURE 4). That is, it is now a general relativistic system, and energy need not locally be conserved. The system can appear to contain either a source or a sink, depending upon the individual system's functioning, to an external laboratory observer. We will return to this effect shortly.

Note the two time lines are of equal length. The negentropy device is producing negative energy and negative time, with respect to the lab observer.

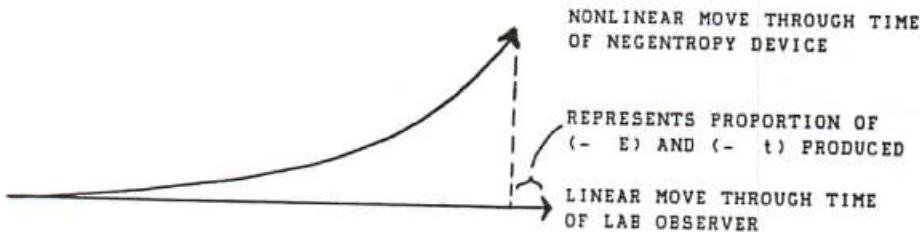

FIGURE 4. Production of Negentropy by Local Curvature of Spacetime Vacuum.

Three Kinds Of Electromagnetics

There are actually three types of electromagnetics (TABLE 1), as I pointed out in my paper [3] to the IEEE Colorado Springs Tesla Centennial Symposium on 11 August 1984:

- a) The ordinary kind of EM, described in classical electromagnetic theory. In classical EM theory, the vector force fields are considered primary and causative, and the potentials are considered to be only mathematical figments. In a region where the force fields are zero, classical EM theory assumes that all the electromagnetic effects cease.
- b) Quantum mechanics, which holds quite a different view of EM. In QM theory the potentials are considered to be real and fundamental, and the EM force fields are merely created from them by differentiation. That is, QM considers the force fields such as E and B to be derived effects, not fundamental causes. Further, when these derived force fields are zero, this only means that the gradients of the potentials are horizontal and hence "zero vectors." The potentials are still there, however, and their interference in a region of zero EM force fields can and does still cause effects. Thus, when classical EM effects reduce to zero, QM EM effects can still exist due to the potentials. In addition to violating classical EM theory, this also violates classical mechanics. It is true and experimentally proven nonetheless. [4] [5]
- c) An extension to the EM view of quantum mechanics, which I have named "scalar electromagnetics." The view of a potential by QM is essentially that it is composed of randomly fluctuating little virtual flux vectors, each representing a moving virtual particle and hence a moving virtual force. That is, QM fundamentally assumes that the virtual vector substructure comprising a potential stress of spacetime is totally statistical and sums to zero. My own contribution, arrived at by noting the work of many unorthodox researchers, is to point out that the virtual substructure need not to be random at all. We can simply form EM force field vector zeros by opposing or summing ordinary E and B vectors, for instance, to a zero vector. In this case, the sum of the absolute values of their magnitudes represents an artificial potential, an artificial stress in spacetime, but one that now has a rigorously deterministic substructure. This represents a deterministic ordering placed into the virtual state (inside the zero vector, in its substructure). We have therefore violated one of the fundamental assumptions of quantum mechanics. We have deliberately ordered and formed the stress of spacetime itself. In other words, we have accomplished general relativistic warping or curving of spacetime as we deliberately chose, and partially ordered the otherwise statistical disorder of the virtual-flux vacuum-ether. The third kind of electromagnetics allows us to transcend many of the limitations of classical EM and of quantum mechanics.

TABLE 1

THREE KINDS OF ELECTROMAGNETICS

CLASSICAL

- > POTENTIALS JUST MATHEMATICAL CONVENIENCES
- > ACTIONS CAUSED BY NONZERO FORCE FIELDS
- > NO ACTION WHEN FORCE FIELDS ZERO

QUANTUM MECHANICS

- > POTENTIAL REAL
- > STATISTICAL SUBSTRUCTURE
- > FORCE FIELDS BY DIFFERENTIATIONS
- > ACTIONS WHEN FORCE FIELDS ZERO

ARTIFICIAL POTENTIALS

- > POTENTIALS REAL
- > FORCE FIELDS EXTERNALLY ZEROED, INTERNALLY ACTIVE
- > ZEROS INDIVIDUALLY DIFFER
- > SCALAR INTERFEROMETRY
- > SCALAR RESONANCE

TABLE 2 shows the specific characteristic features of each of the three kind of electromagnetics. The first two EM's are already proven; the third follows by simple summation of ordinary force field vectors to zero, to produce artificial potentials.

Note what an astounding change this simple vector summation-to-zero, to make an artificial potential, represents to physics. In deliberately forming order in what was previously vacuum disorder, we have accomplished -- simply and directly -- the production of negentropy. We have reduced disorder and increased order.

If so, we must inevitably have produced negative time and negative energy, as seen by the external, linear laboratory observer, as was shown in FIGURE 4.

TABLE 2

COMPARISON OF EM CONCEPTS

Characteristic	Theory Classical EM	Present linear Quantum Mechanics	Scalar EM (Artificial Θ)
Vacuum spacetime	Linear no charge	Linear. Charged (virtual) statistically.	Nonlinear. Charged (virtual) with deter- ministic components.
virtual substructure	none (fluid equations)	yes statistical	yes, statistical deterministically weighted
force in vacuum?	cause yes	effect yes	effect no
zero force fields	no effect	Bohm-Aharonov effects	substructure effects engineerable
potentials	fictionous	real, primary statistical substructures	real, primary deterministic substructures
causative agent	force fields	potentials	potentials and infolded fields of substructures
charge	with mass	with mass	massless
relativistic effects due to	velocity	velocity interfering potentials	interfering potentials
hidden variables	no	statistical negligible	deterministic major role
vector theory applied to EM	okay	okay	requires revision
vacuum EM wave	transverse	transverse	longitudinal with swirls
energy/mass conservation	yes	yes	not necessary anenergy conserved
charge conservation	yes	yes	not necessarily
action at a distance	no	no, except Bohm-Aharonov	yes, scalar interferometer

TABLE 2 (continued) COMPARISON OF EM CONCEPTS

Characteristic	Theory Classical EM	Present linear Quantum Mechanics	Scalar EM (Artificial θ)
scalar (zero-vector) resonance	no	no	yes
inertia is electrical	no	no	yes
gravity is electrical	no	no	yes
mass is electrical	no	no	yes

Negative Time Effects

Eike Mueller's tests of John Bedini's free energy devices directly demonstrate the effects of the production of negative time. That is, the Bedini devices produce some negative time and negative energy, during any macroscopic interval in which they produce positive time and positive energy.

For example, in all three devices Bedini has built to date, a battery is used as an accumulator for the energy, whether it be positive energy or negative energy. By feeding back some "negative potential current" (or δ -dot) to the battery, the battery accumulates -- and charges up with -- negative timespace energy. The battery can furnish the extra negative energy to motors and light lights, with certain peculiarities to be mentioned shortly.

First, however, a most unusual effect occurs in the battery. Note that in modern theory the vacuum is considered to be filled with little "holes" or negative energy states, each normally filled by the electron. (FIGURE 5). This "sea of little negative energy electrons in holes" is called the Dirac sea, after the eminent scientist P.A.M. Dirac, who conceived the theory.

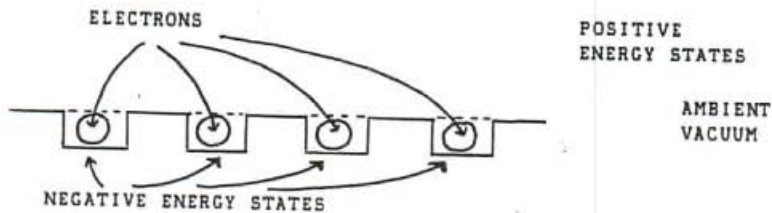

FIGURE 5. The Normally-Filled Dirac Sea

Now, in the negative time portion of the machine's operation, we shall consider that the Dirac sea is inverted. That is, the negative energy electrons will now "fall out of" the holes during the negative time portions, producing negative energy. This of course is real energy, and drives motors and lights. However, a battery which has been charging with negative energy has accumulated a pool of emptied holes in its Dirac sea (FIGURE 6). Everything seems normal, until we remove the battery from the negative-entropy device and hook it up to a normal battery charger. Now we find an amazing effect: the battery will at first "eat" or consume electricity, while the electrons in the charging current are filling the empty Dirac holes. During this filling time, the battery will not recharge to recover its voltage. After these Dirac holes have been filled again with electrons, the battery will start to charge up normally, and will contain normal, positive energy when charged (FIGURE 7).



FIGURE 6. The Partially-Emptied Dirac Sea

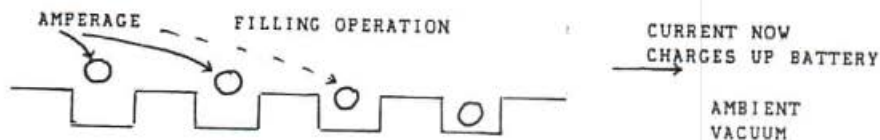

FIGURE 7. Filling The Dirac Sea Holes

On one test, a Bedini battery removed from the operating Kromrey-type device consumed electrical current for 110 minutes before the Dirac holes were filled and the battery started to charge normally.

At the Colorado Springs Tesla Centennial Symposium, the battery from Tom Watson's Bedini-type free-energy device was stolen -- probably by agents who know of the effect, and wanted to see if the battery exhibited the "Dirac fill time" effect. That is, they could absolutely ascertain whether or not his device was real, simply by testing the battery to see if it exhibited the effect.

On any free-energy device which is powered from a recharging battery, this is a positive test to ascertain whether the device is genuine or a fake.

Other negative time effects are evidenced by a motor running at least partially on negative energy. The way to understand these effects is to reverse in our minds what would happen to a normal motor running on positive energy and positive time.

For example, one may visualize a motor running at constant speed as containing some constant value of energy at any given time. If all the energy is positive and the time passing is positive, when one shorts the terminals one removes positive energy. The motor thus dies. On the other hand, if the motor contains a negative energy and negative time, shorting the terminals removes negative energy and negative time. This is equivalent to increasing negative energy in positive time. Therefore the laboratory observer will observe the motor to increase its speed when the terminals are shorted. Eike Mueller directly observes this effect in the Bedini device.

Similarly, if one adds additional loads to a negative energy/negative time motor, one is again removing negative energy and negative time, which is identical to adding negative energy in positive time. Thus again the motor increases its speed precisely as Eike Mueller's tests showed.

Additional negative time effects are exhibited. Utilization of negative energy produces IR² cooling instead of heating. Thus resistors and semiconductors run cold. The more load added, the more negative energy current drawn -- and devices get cooler, even though the lights get brighter and the motor runs faster. Also, to the negative energy/negative time operation, the frequency/temperature spectrum appears to be inverted. That is, instead of "heating up" through infrared, into visible, into ultraviolet, and into X-rays and gamma rays, the negative energy device exhibits "cooling down" from gammas to X-rays to visible to infrared. In this manner one finds that a simple low voltage (positive instrument measurement!) spark exhibits profoundly unusual effects: Its negative time/negative energy/"voltage" may be extremely high. The spark therefore may appear of extraordinary length for the (seemingly) low voltage indicated by positive-time instruments. In addition, the spark may be unusually rich in UV emission or X-ray emission. For uncontrolled very high-energy negentropy devices, even gamma emission may be observed from seemingly

"low voltage" devices. The long-sought X-ray laser and gamma ray laser should be easily constructable along negative entropy device principles.

These are just some of the exciting effects that have become apparent in the negentropy devices built by John Bedini. Further, John has magnanimously released sufficient details so that other experimenters can produce working models of two of his devices. Tom Watson has already successfully replicated the first Bedini motor, and scaled it up into a much larger device. In addition, Eike Mueller himself has replicated a simplified version of Bedini's Tesla switch device.

We are on the threshold of a new science, a new world, and a new life, given to us by the pioneers such as Tesla, Moray, Bedini, and others.

Let us get on with it and put it to immediate use to power our cities, our homes, and our industries.

References

- [1] Bearden, Thomas E., "Guiton/Perceptron Physics: A Theory of Existence, Perception, and Physical Phenomena," March, 1973, NTIS # AD 763210
- [2] Ibid.
- [3] Bearden, Thomas E., "Tesla Electromagnetics and Its Soviet Weaponization," presented to the IEEE Tesla Centennial Symposium, Colorado College, Colorado Springs, Colorado 11 August 1984
- [4] Y. Aharonov and D. Bohm, "Significance of Electromagnetic Potentials in the Quantum Theory," The Physical Review, Second Series, 115 (3), August 1, 1959, pp. 485-491.
- [5] R.G. Chambers, Phys.Rev.Lett., Vol.5, 1960,p.3.

ADDITIONAL TESTS BY EIKE MUELLER

30 August / 1 September 1984

In the first series of tests I used the rotary switch. The batteries were labeled as #1 and #2 (left side) and #3 and #4 (right side).

Here are the major events.

- EVENT 1 Start at 12:25 pm; voltage measurements taken.
- EVENT 2 At 12:45 pm voltage measurements taken.
- EVENT 3 At 1:00 pm the 12V, 75W lamp replaced by a 110/10V transformer.
- EVENT 4 At 1:15 pm voltage measurements taken.
- EVENT 5 At 1:30 pm test stopped, voltage measurements taken.

TABLE 1 shows the detailed voltage measurements during the conduct of this test.

TIME	12:25	12:45	1:00	1:15	1:30
EVENT	1	2	3	4	5
VOLTAGE					
BATT.#1	12.0	12.0	12.1	12.1	12.1
BATT.#2	11.9	11.9	12.2	12.2	12.2
BATT.#3	12.2	12.1	12.7	12.8	12.8
BATT.#4	12.2	12.2	12.7	12.7	12.8

TABLE 1 TESLA/BRENTTE/BEDINI SWITCHING DEVICE FIRST SERIES

PICTURE 1 shows the conduct of this test. The batteries were labeled from #1 to #4 from left to right. In the center the rotary switch, and to the left of it the potentiometer for its speed control (frequency control of circuit), can be seen. To the right of the rotary switch is the relay which switches the battery banks. To the right of the relay is the 12 V, 75 W quartz lamp which is connected to the negative terminals of batteries #2 and #4.



PICTURE 1 FIRST SETUP OF TESLA SWITCH EXPERIMENT

At 3:00 pm the Tesla switch was reconnected. This time the relay was driven by the timer which was built by Louis Pollaehn of COMTEC. FIGURE 1 shows the circuit diagram for this timing device and PICTURE 2 shows the solid state timing device in operation.

LOUIS POLLAEHN'S TIMER

30 AUG. 84

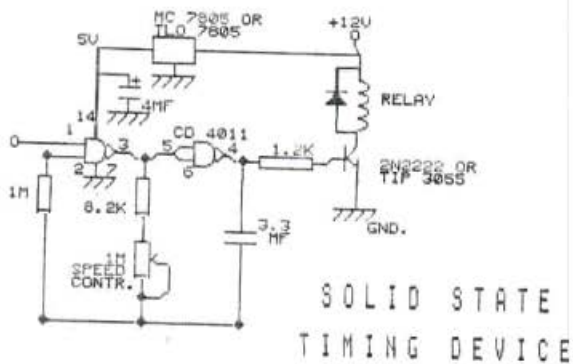
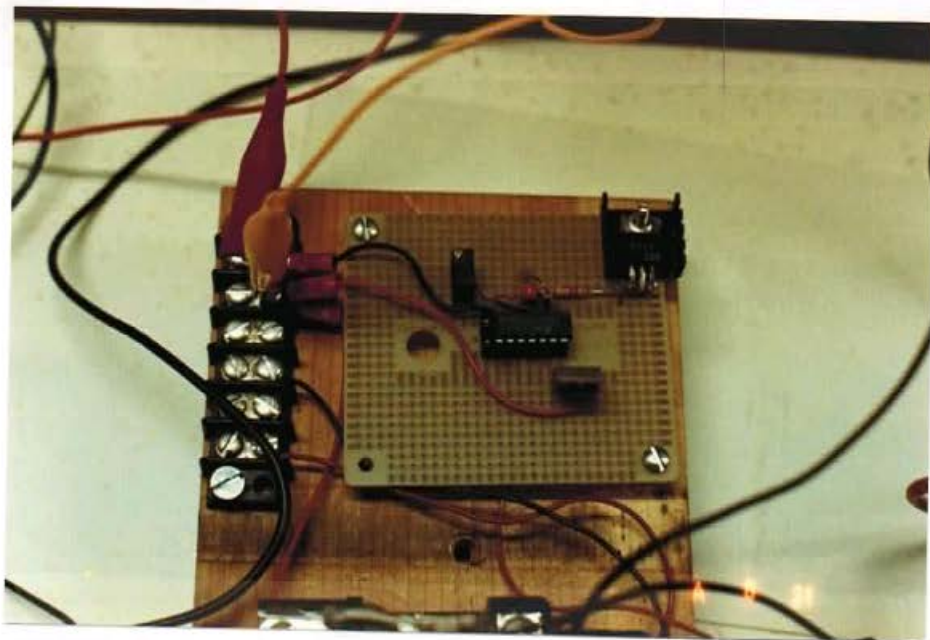

FIGURE 1 CIRCUIT DIAGRAM OF TIMING DEVICE BY LOUIS POLLAEHN



PICTURE 2 THE SOLID STATE TIMING DEVICE IN OPERATION

Test history:

- EVENT A At 3:10 pm test started, load was a 110/110 V transformer between the two negative terminals of batteries #2 and #4. The secondary side the transformer was connected to two 40W, 110V light bulbs in parallel.
- EVENT B At 4:00 pm voltage measurements taken.
- EVENT C At 4:30 pm a small 110 V fan was added in parallel to the two 110 V light bulbs.
- EVENT D At 5:40 pm a 12 V, 75 W quartz lamp was connected to Battery #1.
- EVENT E At 6:00 pm voltage measurements taken. PICTURE 3 shows this setup. At left is the quartz lamp connected to battery #1. In the center foreground are the two incandescent lamps. To the right of the lamps is the 110 VAC fan. Behind the fan and out of sight is the relay. Next is the 110/110 V transformer, hooked up to the two negative terminals of batteries #2 and #4. The solid state timing device is located between the transformer and battery #4.



PICTURE 3 Tesla/Brentte/Bedini Switching device loaded with two 110V light bulbs, 110V fan and a 12V 75W quartz lamp.

- EVENT F At 6:30 pm voltage measurements taken
- EVENT G At 7:00 pm one 110 V light bulb disconnected
- EVENT H At 7:25 pm the same 110 V light bulb connected back into the circuit

TABLE 2 shows the results of this test.

TIME	6:15	6:30	6:30	6:40	6:00	6:30	7:00	7:25
EVENT	A	B	C	D	E	F	G	H
VOLTAGE								
BATT #1	14.0	12.7	12.1	12.3	12.2	11.7	11.8	11.9
BATT #2	13.1	11.3	11.5	11.4	12.0	11.1	12.1	12.1
BATT #3	14.1	14	12.8	13.0	10.9	12.7	11.4	11.3
BATT #4	13.3	11.7	12.4	11.5	12.4	12.5	11.4	11.3

TABLE 2 TESLA/BRENTE/BEDINI SWITCHING DEVICE SECOND SERIES

TABLE 3 shows the continuation of above measurements.

Here again first the events:

- EVENT I 8:30 pm voltage measurements taken.
- EVENT J 9:15 pm voltage measurements taken.
- EVENT K 10:30 pm voltage measurements taken.
- EVENT L 11:05 pm voltage measurements taken.
- EVENT M 11:30 pm voltage measurements taken.
- EVENT N 10:30 am (1 Sep) discovery after unit has been operated during all night that both 110 V lamps were out and that one wire was broken due to overheating. Voltage measurements taken.
- EVENT O 11:30 am voltage measurements taken.
- EVENT P 3:00 pm all lights again out, voltage measurements taken. The low voltage of battery #2 - marked with (*) in the TABLE 3 - is most probably caused by the back EMF from the transformer. The ideal transformer would be an inverter transformer 10 V to 110 V.

The summary of this test can be seen in TABLE 3 which is a direct continuation of TABLE 2.

TIME	8:30pm	9:15	10:30	11:05	11:30	10:30am	11:30	3:00pm
EVENT	I	J	K	L	M	N	O	P
VOLTAGE								
BATT #1	11.7	11.8	12.0	11.8	12.0	12.5	12.5	12.0
BATT #2	12.1	12.0	12.1	11.9	11.7	12.5	12.5	5.0 (*)
BATT #3	12.4	12.4	12.4	12.5	12.5	12.5	12.5	12.5
BATT #4	12.4	12.5	12.5	12.4	12.5	12.5	12.5	12.0

TABLE 3 CONTINUATION OF MEASUREMENTS SHOWN IN TABLE 2

The total test run is summarized in GRAPH 1 on the following page. In this graph I show the voltages of all batteries over the test time in hours.

TESLA/BRENTTE/BEDINI SWITCHING DEVICE TESTS

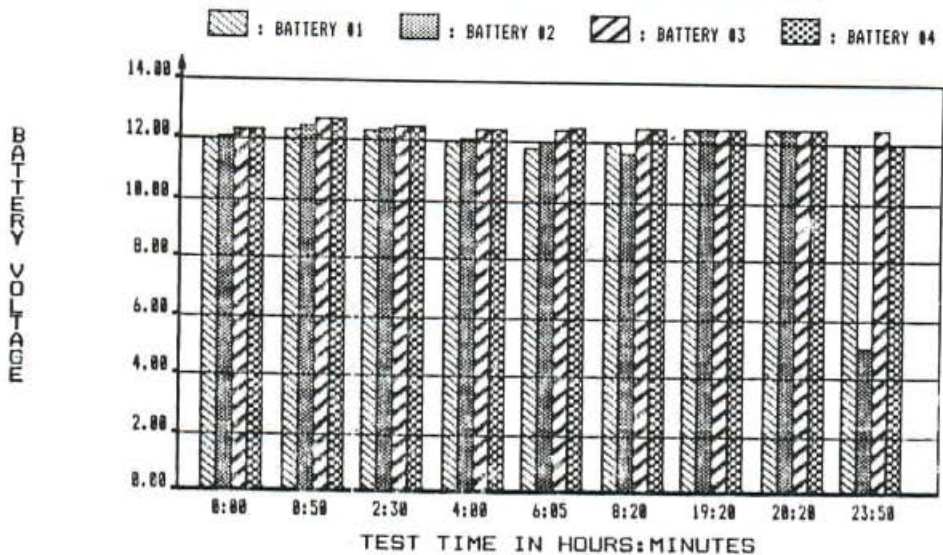

GRAPH 1 TESLA/BRENTTE/BEDINI SWITCHING DEVICE TEST SUMMARY

EM/506281

Gravity Field Generator

Manufactured by

John Bedini

An Interpretation by

Tom Bearden, Tom Herold and Eike Mueller

June 1985

A Gravity-Wave Generator

This precision device is not a so-called "free energy" machine, and it is not a "perpetual motion" machine. In our opinion it is an unusual gravity-wave generator (or gravity field converter). It utilizes the zero-summed electromagnetic stress of the vacuum to oscillate the magnitude of the stress energy tensor of the vacuum. In other words, it directly converts electromagnetic waves/energy to gravitational waves/energy. Our interpretation is based primarily on the first Bedini G-field system which Eike Mueller tested and Tom Bearden examined. The present device is a scaled-down version of the generator portion of that system, to allow experimentation by independent researchers. Note that the inventor himself makes no claims for the device whatsoever. The researcher must make his own tests and draw his own conclusions, which may or may not agree with our interpretation here.

- Ordinary General Relativity/Unrestricted General Relativity -

Ordinary general relativity assumes a Lorentz frame at the observer's location. Thus, under this assumption one has special relativity locally, and not general relativity. Such a situation retains the conservation laws for the observer, including the conservation of energy law. In other words, ordinary general relativity is normally restricted to only a special case of Einstein's full and unrestricted general relativity. On the other hand, if the local spacetime of the observer/instrument is curved so that the local frame is not a Lorentz frame, then conservation laws need not apply locally. This includes conservation of energy, conservation of charge, conservation of momentum, etc. This is the unrestricted and general case of general relativity. It is the case upon which the Bedini G-field generator deliberately capitalizes.

Theoretically, the Bedini G-field generator, by producing a gravitational wave, is producing a local oscillation in the curvature of spacetime. Thus it applies unrestricted general relativity to the local frame. The purpose of the Bedini G-field generator is to show that, far from being just a theory, unrestricted general relativity is eminently engineerable, as are gravitational waves themselves.

- A Vector Principle Missing from Physics -

The Bedini G-field generator applies a vector stress principle which has been inadvertently omitted from physics and electromagnetics. Missing from ordinary physics and electromagnetics is the case where electromagnetic force field vectors in a vector field system remain dynamic and yet always sum to zero-resultant electric field and zero-resultant magnetic field. Note that such a zero-vector (scalar) system has infolded energy, in deliberate and dynamic vacuum polarization patterns. These are occurring "inside" the vector zero, directly in spacetime itself. A priori, the individual components of the zero-vector summation in such a system polarize the vacuum in a deterministic manner, and together they produce a gravitational wave since they oscillate the vacuum stress energy vector itself. In fact, such an "artificial potential" forms three distinct artificial potentials in vacuum: (1) electrostatic scalar potential; (2) magnetostatic scalar potential; and (3) gravitostatic scalar potential. This can easily be seen by examining such a "zero vector" scalar system in Kaluza's 5-dimensional geometry (published in 1921), which unified electromagnetic field and gravitational field into one common field theory.

- The Generator Viewed in Kaluza Geometry -

In Kaluza 5-dimensional geometry, the 5-dimensional gravitational field intersects our normal world in two manners: First, the 5th dimensional aspect of the 5-dimensional gravitational field is seen by us as our electromagnetic field; and second, the remaining aspect of the 5-d gravitational field we see as our normal gravitational field. This is graphically illustrated in Figure 1. Passing to Figure 2, it can now be seen that an internally "pumped" vector-zero scalar electromagnetic system constitutes a direct conversion of electromagnetic energy into gravitational energy and vice versa. That is, by holding the electromagnetic "leakage" to zero, and pumping the zero with energy in and out, the 5-d gravitational field is pumped outside its 5th dimensional aspect, resulting in the direct pumping of our 4-dimensional gravitational field.

GRAVITY AND ELECTROMAGNETICS

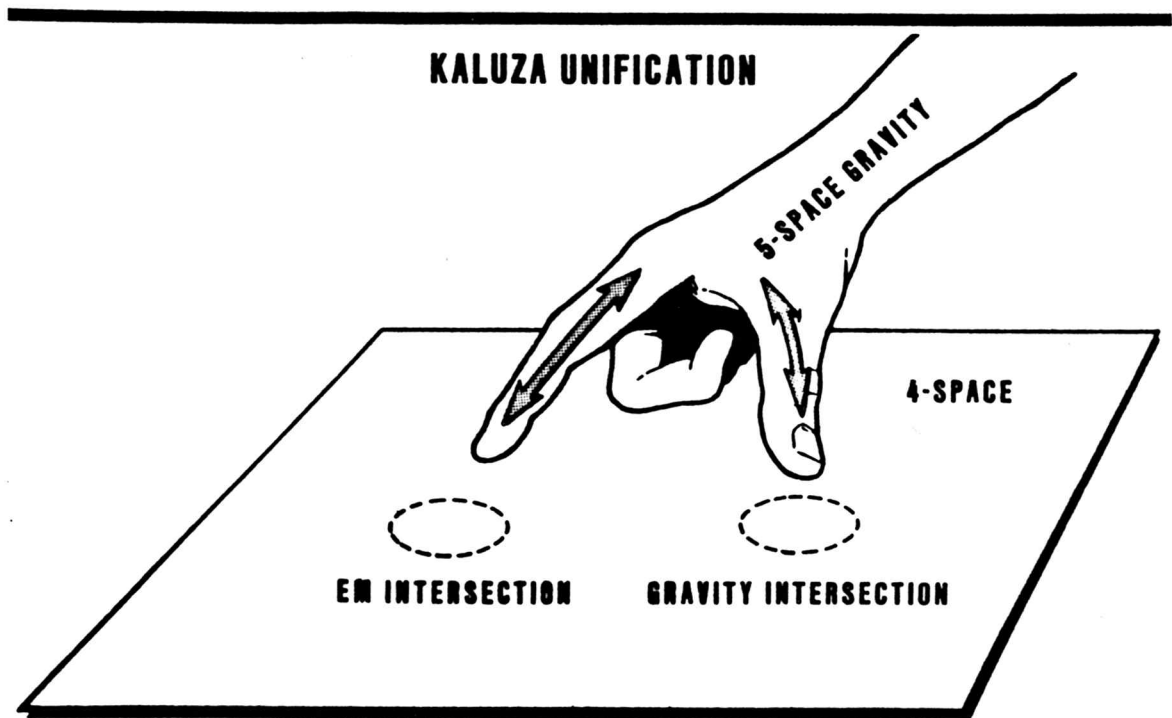

FIGURE 1

This model is diagrammatic only. Actually, both the electromagnetic intersection and the gravitational intersection exist at the same point in our world.

HOW SCALAR EM AFFECTS GRAVITY AND CURVES SPACE TIME

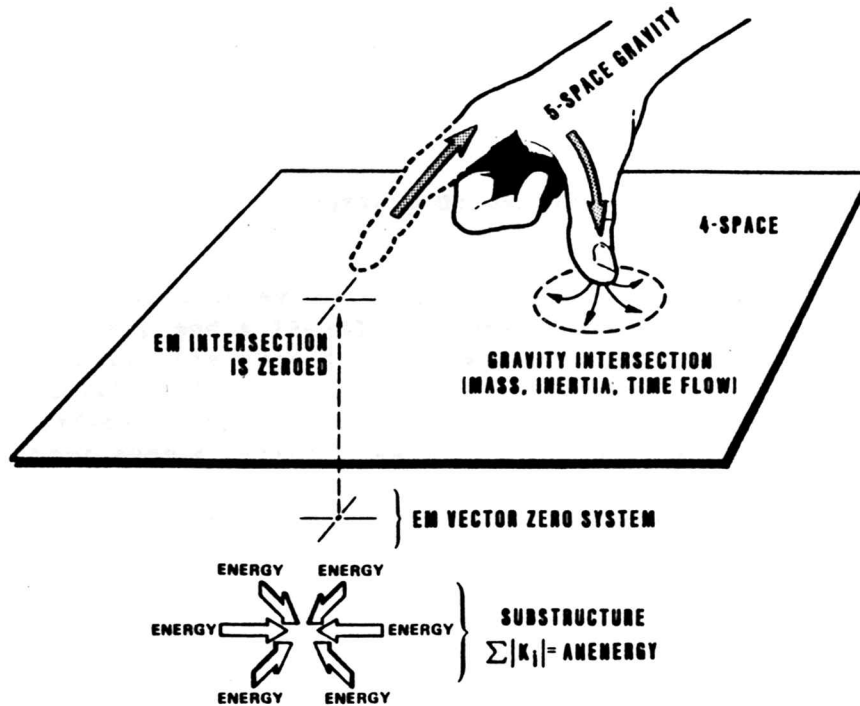

FIGURE 2

- Zero-Vector Currents -

The Bedini G-field generator is an educational research tool to allow experimentation with the effects of such electro-gravitational waves on materials and equipment. It also allows many phenomenology experiments to be performed. For example, the "zeroed current" (scalar current) output component of this generator will not run an induction motor, nor can it be accurately measured by ordinary "electron movement" instruments. This is because the scalar currents do not directly involve the electron shells of the atoms. Instead, they arise in the nucleus, pass through the electron shells, and interact with other nuclei. Electron shell effects in the atom occur only as an entrainment result of changes induced directly in the nucleus by scalar currents and waves. This "nuclear electricity" is not presently in the conventional textbooks or literature. (Note that the device is not perfect, and the sum zeroing is not perfect in any real machine. Thus a small "normal" component is produced in addition to the scalar currents of gravitostatic stress directly in the nuclei.)

On the other hand, the scalar current will power resistive loads by an internal magnetostrictive and electrostrictive microscopic effect. Essentially, small micro-currents in random directions are induced in the resistor by magnetostriction and electrostriction, due to oscillation of the magnitudes of the induced vacuum polarizations and due to oscillation of the magnitude of the vacuum stress energy tensor. General relativists will immediately see the implications for change of local gauge, etc.

- A Battery-Driven System -

A 12-volt DC permanent magnet motor is the preferred drive motor for the generator, and a 12-volt battery is the preferred power source for the drive motor. The experimenter may also wish to adapt or alter the design by addition of a flywheel, and a rectifier to recharge the battery during the off-cycle time, which can be provided by a controller-switcher. Figure 3 shows such a typical system. It is also advisable to install a flywheel of several pounds. When such a system is properly tuned, the battery will run the system for a much longer time, prior to needing recharge, than in the normal mode (without the G-field generator).

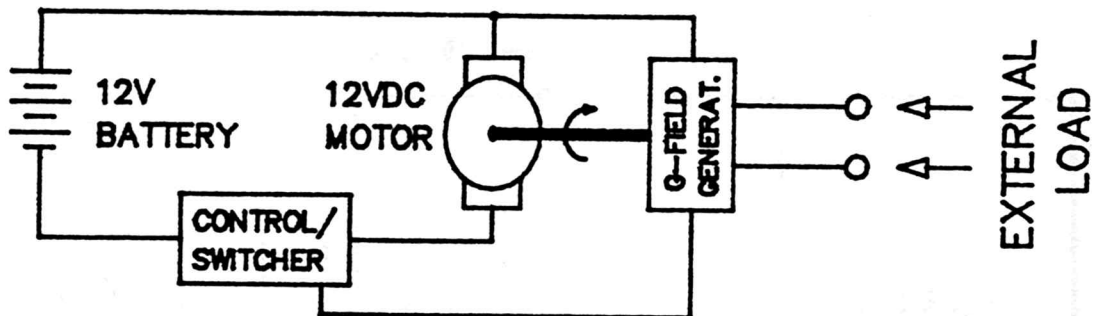

Schematic of
Bedini's G-Field Device

When operated in such a system, the unit will demonstrate several major anomalies, such as:

- (1) The greater the load drawn from the generator, the faster and easier the generator runs and the less drive power is consumed by the 12-volt DC drive motor.
- (2) The generator will run even more easily and faster with its output shorted, and will not be quickly damaged by this operation.
- (3) A resistive load can be supported through even a 40 or 42 gauge wire, and it will be very difficult to measure any appreciable normal current, or power, going through this fine wire to the resistive load. Normal instruments will usually record far less power going through the wire to the load than can be seen or measured being actually radiated away from the load and thrown out of the system in the form of light and heat. Figure 4 shows a typical result for the larger unit tested by the authors.

BEDINI'S G-FIELD GENERATOR (KROMREY-TYPE DEVICE)

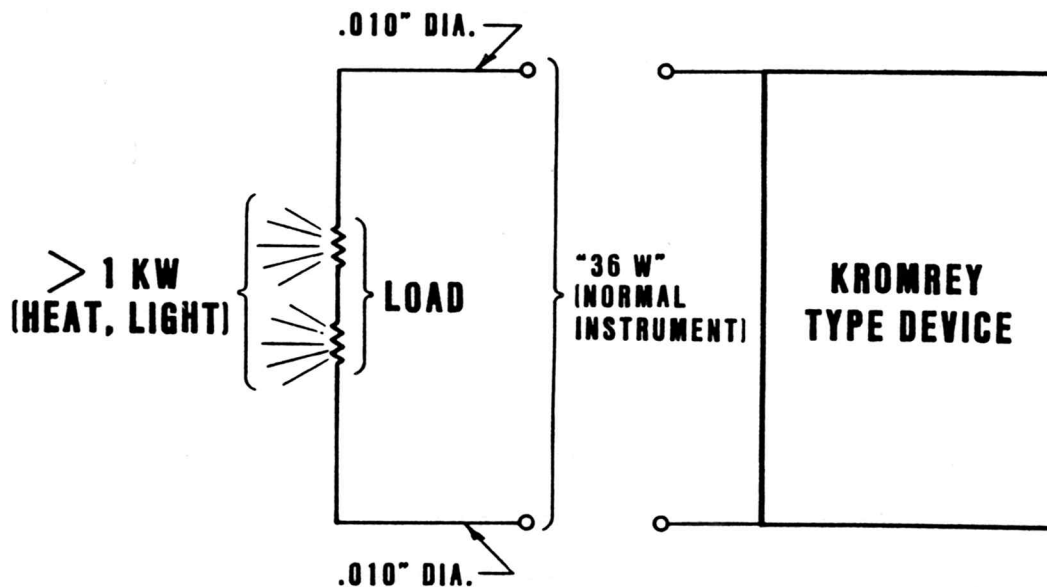

FIGURE 4

- A Final Remark -

The G-field generator thus can be used to demonstrate the "weak principle" of local spacetime curvature and "local violation" of the conservation of energy law. According to the normal electromagnetic theory and special relativity, the resistive load itself seems to be producing more output energy than is being furnished to it. The extra energy, of course, is coming from the local curvature of spacetime, from the conversion of spatiotemporal potential to ordinary electromagnetic energy. The "extra energy" is contained in a "zero-summed" electrogravitic current flowing in the wire to the load, and in the load, this so-called "anenergy" is converted to ordinary electromagnetic energy and thrown away, out of the system.

The Bedini G-field generator provides a general relativistic system at the load itself, and thus the local load is not operated in a Lorentz frame. Other anomalies can be found in various experiments, limited only by the ingenuity of the experimenter.

Disclaimer

The Bedini G-field generator is intended to be a research and educational tool ONLY. No claims whatsoever are made for it by John Bedini or by Bedini Electronics, Incorporated. The generator is not warranted as to merchantability, or as to suitability for any particular purpose or use.

NEITHER JOHN BEDINI NOR BEDINI ELECTRONICS, INCORPORATED SHALL BE LIABLE FOR ANY DIRECT, INDIRECT OR CONSEQUENTIAL DAMAGES OF ANY KIND, RESULTING FROM THE SALE OR USE OF THIS PRODUCT.