

**Correcting the Lie of Physics ~ Energy is not Always Conserved**

**The Conservation of Energy is not a Law. It is a Condition.**

**Vinyasi**

**2022 April 12**

## **Table of Contents...**

### **Introduction in Two Parts followed by an Appendix**

Chapter One: What is the Limited Jurisdiction of the Conservation of Energy?

Chapter Two: What is Gravity versus Levity? And where do UFO's come from?

### **Appendix in Three Parts**

Free Energy is the Non-Saturation of Inductor Current

Figures for Text, which follows, of my application for Provisional Patent

Text, for the preceding Figures, of my application for Provisional Patent

# Chapter 1: What is the Limited Jurisdiction of the Conservation of Energy?

Abstract – “Free Energy” is *not* a fantasy. Reactance, alone, is adequate to make up the difference for whatever environmental power, or manmade source of power, is not adequate for powering all of our devices.

The conversion of the unlimited resourcefulness of reactive power into consumer friendly real power, and at an adequate rate of their accumulation over time, makes the use of reactive power a profitable enterprise. This conversion can be effected by at least three different methods...

1. Resistance – reassembles the oscillating phases of voltage and current reducing their angular difference to zero degrees of separation within the confines of a resistor.
  - (a) The efficiency of this method is detracted by the generation of heat and light, etc.
  - (b) Yet, it is *this inefficiency* which can replace all nuclear power plants if we do not also insist upon perpetuating the myth that the nuclear production of plutonium is a necessity of modern life.
    - i. Nuclear power plants give us no energetic (A), nor conversion (B), advantage over reactive power.
      - A. Reactive power can accumulate to any amplitude within any desirable time frame, from: a minimum of nanoseconds to a maximum of tens of thousands of seconds.
      - B. A resistive heating element (powered by reactive power) is adequate for boiling water into the production of steam to drive turbines and rotate electric generators.
    - ii. This avoids the massive manufacture of plutonium for nuclear warheads. Plutonium is the unavoidable result of the operation of *any* nuclear reactor.
      - A. Most of the plutonium *is never used* for anything *other than* the manufacture of nuclear warheads.
      - B. None of our nuclear warheads are attached to the head-end of our missiles. They are simply tallied as part of our arsenal in the game of “Nuclear Detente”, ergo: who has how many warheads determines who can saber-rattle the loudest.
    - iii. This also avoids the risk of another: Three Mile Island, Chernobyl, Fukushima, etc. These risks have proven to be far greater than any threat of attack which might necessitate a nuclear detente. We are our own worst enemy.
    - iv. If every country is capable of becoming well-endowed with enough reactive power technology to satisfy all of its need for electricity, then what is the excuse for *continuing to increase* a nuclear arsenal and ignore the fallacious secrecy behind freely available reactive power.?
2. A full bridge rectification, of A/C into D/C, brought about by four diodes, cancels any separation between the phase of voltage versus the phase of current in an oscillating circuit. This unification is brought about by the eradication of oscillations when direct current is

converted into an alternating current. Oscillations precede any possibility for separation to occur. *{Without oscillations, the angular separation of voltage phases from the angular position of current phases cannot occur.}* Efficiency is, likewise, affected by losses (due to conversions) into heat and light, etc. But this is a simple remedy which neutralizes the criticism that “it is useless to utilize lossless reactive power”.

- (a) By its very nature of “losslessness”, reactive power of negative wattage (possessing  $180^\circ$  of separation between its voltage phases and its current phases) can do nothing other than accelerate its escalation to an infinite accumulation of amplitude until it is converted into real power (which will put an immediate halt to this escalation).
- (b) But a circuit may be segregated into different areas which insures that each area specialize in one characteristic or another. In other words, the accumulation of reactive power can proceed, indefinitely, and we can still make use of it by way of its conversion into real power, by the use of segregation. This way, the production of reactive power in one area can be protected from its termination while the conversion of real power can be “drawn off” into a second area (of the union of voltage and amperage) to insure the continuation of the accumulation of reactive power in the first area.
  - i. The conventional wisdom of transformers breaks down since there is no “draw” of power taken from the primary coils and transferred to the secondary coils since there is no “throughput”. So, how can there be any “draw” of power from one place which is transferred to another place? For these reasons...
    - A. One area may be high in voltage while low in current.
    - B. Another area may be high in current possessing no voltage.
    - C. Yet, current continues to exhibit the characteristic behavior of “flowing” within each component.
      - This throughput is broken whenever the orientation of current is diametrically opposed to the orientation of voltage.
      - The consequences are that...
        - Quality factor is no longer relevant since “Quality” is a ratio of the measurements of throughput. Without throughput, there are no measurements of “Quality” which could be proportioned. “Quality factor” literally means, or implies, “a quality of throughput”.
        - “Quality” cannot exist without a foundational concept of a logical throughput which sequences a logical series of causations followed by their effects, followed by more effects, in an endless series of causes and their consequential effects.
          - Only the brutal application of voltage can insure “throughput”, namely: an endless series of logical causes followed by their effects.
          - On the other hand, without brute regulation from a regulated source of voltage, or a regulated source of current, the endless trend of the accumulation of reactive power becomes possible. This process (of reactive

accumulation) invalidates a sequentially logical “quality” of throughput.

- We can no longer delude ourselves into believing that a potential of voltage “pushes” current and maintains its movement if current can “travel” from areas of low or no voltage (pressure) towards areas of higher voltage (pressure) whenever current is oriented with a polarization which is opposed to the polarity of its voltage.
- This reversal of current opposes conventional logic. Conventional logic believes that the purpose of current is to reduce the difference of voltage occurring between the source of current versus its target.
- This reversal of current insures the continuous *increase* of voltage difference between the areas of high voltage pressure versus the areas of low voltage pressure.
- This begs the question, “Is current real or is current a fiction”? One of the versions of Ohm's Law claims the latter, in that...
  - The application of voltage results in a change in voltage (over time) due to resistance. Or put another way (mathematically speaking), “voltage is squared and then it is divided by resistance for it to equal power” measured in watts.
  - This phrases our definition of Ohm's Law in a manner that encourages an honest appraisal of: “How does electrostatics operate regardless of whether or not it is operating without the “authority” of an overbearing source of voltage (directly via a voltage source or consequentially via a current source)”?
    - Because, *without* an overbearing source of voltage, current is free to arise from a circuit's reactance arising from the lack of an authoritative source of voltage.
    - But, *with* an overbearing source of voltage, current is not free to “do its own thing” and must conform to the “Conservation of (Kinetic) Energy” espoused by physics. In other words, any reactance of a circuit supplied by an overbearing source of voltage (or a current source masquerading as a source of voltage) is prevented from generating its own current without assistance from an externalized prime mover. Ergo, a coil may not generate current in a manner which is not recognized by our present-day understanding of Faraday's Law of Induction, because this generation is *external* to a circuit and outside of its reactive components.
- Current is merely a tool, an artifice, of the technician who wants to simplify a current-free version of Ohm's Law by substituting a single variable (known as current) to replace the more complicated voltage divided by resistance ratio rendering Ohm's Law into an elegantly simplified version known as, “current times voltage equals power”.
- This creation of an oversimplified and fictional concept, known as “current”, presupposes another fictional artifice emanating from the mind of man called: the photon, which facilitates the transference of voltage from

the tail-end of current and moves it towards the target of current.

- All of this arises from an age-long brainwashing promulgated by the experiences of primitive man (and maintained in modern society) regarding a mass of water streaming down a river and what it feels like to stand in the middle of that and feel the pressure which this flow exerts against the body.
- But the valence electrons of neighboring atoms of copper (in a coil of wire) share the electrons of their valence shells. It is this mutual agreement to simultaneously share their valence electrons (among each other) which makes possible our creation of a fictionalized appearance of a flow of current.
  - Yet, all they (these valence electrons) are doing is communicating with one another – without any flow of electrons moving among them – since all of these valence electrons are already being mutually and simultaneously shared among the entirety of electrically connected copper atoms.
  - This communication causes ripples of waves to manifest within electromagnetic materials prompting the modernized mind of man to seek an explanation for these ripples.
    - The mind of man is oriented towards seeking patterns.
    - Yet, patterns can mistakenly replace the cause for those patterns within the mind of man. In other words, we (more often than not) misappropriate the ripple as its own causation when in fact it is merely the result of voltage states (of the valence electrons of successive atoms of copper, for instance) rising and falling in a pattern which suggests lateral “rippling” movement when no such movement occurs. *{See, Laithwaite footnote, below.}*
    - The duty of every scientist is to remain free of prejudice. Yet, we are not free from prejudice.
    - For, if we were free from prejudice, we'd see a magnetic ripple (occurring within a conductive medium) and recognize it for what it is, namely: a successive rise and fall of electron volts within the valence shells of copper atoms along the length of a transmission line or within a coil of wire.
- Thus, the more massive is a copper wire, then the larger is the stockpile of shared valence electrons and the total potentiality of charge which is available for reactance to occur or for the fictional transmission of a rippled pattern of changing states of voltage (misabeled: current) occurring along the length of a transmission line (for instance).
  - Since the valence charge is what binds copper atoms together as a wire or a coil,...
    - No external source of voltage (or frequency) can supersede this limit, for that would necessitate the detonation of that copper wire into nano-fine particles of copper dust.
    - Nor can any reactive voltage supersede this limit, for the result would be the same.

- This is what determines the amplitude of reactive power – not the conventional wisdom of voltage pressure coming from outside of a copper wire and entering into it to infuse it with a power which it did not already possess. This is a fiction and a lie.
- No material substance lacks power. All of matter already possesses all of the power we could possibly need. All it lacks is the a catalyst to initiate its use.
- This catalyst enters into a circuit from outside (of the circuit) in the form of its designer who instills within it a conscientiousness of responding towards changes in the voltage potential of its constituent components. This is the definition of “consciousness” which might be better represented by “conscientiousness”, ergo: responsiveness to change.

3. Two counter-wound coils. The current of coil “A” will be in-phase with the voltage of coil “B” and the voltage of coil “A” will be in-phase with the current of coil “B” if both coils possess any mutual inductance. Their mutual inductance will determine the efficiency of this method of conversion.

The benefits of reactance is only available as a “free potential of energy” if the voltage input of the prime mover at the source is drastically reduced to levels of amplitude similar to the environmental voltage of a few microvolts. Otherwise, anything higher than an input of three volts, more or less, will suppress this abundant potentiality of reactive power to “make up the difference” for any inadequate source of voltage.

For “free energy” to exist, reactive impedance must supersede input voltage. This blocks throughput of current, yet, provides for the possibility – not the probability – of reactance providing an abundance of reactive power in excessive quantities greatly surpassing any finite input. This lack of throughput – intended to overcome impedance (due to an inadequate input) – is only a “design failure” if reactance is not encouraged to accumulate due to the phase separation of voltage from current by one-half cycle of oscillations (or, 180°).

Under conventional conditions of flashlight circuit topology (in which a voltage source overwhelms any impedance or resistance offered to the flow of current), throughput manifests a consistency of polarity in which the orientation of current is consistent with a passive sign convention. In other words, current possesses the same polarity of orientation as does voltage if it is considered outside of any voltage “source” of the real input of power.

But if non-conventional conditions of elevated impedance supersedes a scanty voltage input, then it is possible to take advantage of this “apparent challenge” and generate reactive power in an endlessly, escalating quantity.

The net result will be a total denial of a logical throughput. Power will be consumed by some components of this type of circuitry at a rate far in excess of its generation at other locations within this circuit. Overall power (consumed or generated) will steadily and consistently increase at an exponential rate. And all of this occurs apart from any significant input from a voltage “source”.

*For example... Quite frequently, I'll find myself constructing an input predicated upon a voltage division intended to throw away a large percentage of the input of voltage (coming from a sine wave source) by passing this excessive voltage (excessive by my standards) to a grounded node (separate from any other grounded node) so as to insure the lack of reactive suppression.*

This defies reason if we assume that a throughput of current is required for *all* types of power supplies. But I am suggesting a denial of the throughput of current, as brought about by a reduction of input, so that this denial of throughput will provoke an abundance of reactive impedance and resistive impedance and replace the need for a transmission of power from one location to any other location.

The consequence is that only information travels through this style of circuitry; not current. This information manifests as a change in state of neighboring components, such as: a change in the voltage (potential) among the valence electrons among immediately adjacent copper atoms in a coil of wire.

The laws of physics and chemistry deny the copper atom any free will. The valence electrons of copper atoms *must* perform their lawful duty of responding to a change of state among their neighbors since their neighbors are not strangers: atoms of copper drifting aimlessly out in space. No. These neighbors share their paltry valence charges so as to incorporate their neighbors into a cooperative dance of ripples effecting the movement of electrodynamic matter without requiring any movement of energy down the length of a piece of copper wire as demonstrated by Eric Laithwaite in his video lecture (cited, below).

But this does not require a throughput of current to carry this information from the valence electrons of one copper atom to the valence electrons of another copper atom. The dielectric medium of empty space is adequate for servicing the need for informational *storage* between the valence electrons of adjacent copper atoms. And each copper atom possesses the necessary dynamics to register a voltage potential within their valence electrons indicating a charge of potential exists across the empty space between those two copper atoms in a manner similar to how the conductive plates on either side of a capacitor's dielectric medium does, likewise.

Photons are an unnecessary “hypothesis” which does nothing to explain electrodynamics and does everything to confuse it!

Thermodynamics is a phenomenon of throughput. It cannot address the “broken” condition of current and voltage phases of oscillation separated by one-half cycle of temporal distance.

Thus, there is no law of physics which *requires* a transference of energetic throughput for energetic dynamics to occur. Thermodynamics merely specifies the mechanisms of losses and conversions *predicated upon throughput*, yet is silent whenever throughput is overwhelmed by reactance.

What follows (in Appendix A) are screenshots of the segregated analysis of a few circuits to exhibit:

1. A throughput – which is consistent with an energetic output equal to its input, or...
2. A non-throughput of inequalities between input and output.

Since the logic behind a throughput of current has been destroyed by the separation of the phases of voltage from the phases of current by one-half cycle of oscillations, then the logic of accountability is also shattered since we can no longer account for the logical causations of all energetic movements.

Energetic movement is a consequence of throughput. Without throughput, energetic movement cannot occur. Instead, we get characteristic behaviors which are *indicative* of the consumption versus the generation of power whenever power is positively signed (as positive wattage) versus negatively signed (as negative wattage). But this is a presumption on our part misappropriating one set of conditions onto another,



namely: *superimposing a presumption of throughput under all circumstances even when it has not been “authorized” by an overwhelming source of voltage!*

I have seen spark gaps “authorize” the transformation of inductors – originally intended to consume power as an “Inductive Load” – convert themselves into producers of reactive power in a manner which is consistent with the passive sign conventional definition of a generator of power. And no prime mover is required to move these inductors through a magnetic field in order to energize the flow of current passing through these coils. All that is needed is to split the proverbial atom of real power into its two fragments of the electromotive force and the magnetomotive force and rearrange their angular relationship with each other into a diametrical opposition of 180° of phase separation. And I have seen these same spark gaps consume power at a rate far in excess of its production at nearby inductors!

All of this will be substantiated with screenshots of simulated circuits located within the Appendix and are also found within my application for provisional patent.<sup>1</sup>

Triangular waves occurring within an inductor is an indication of that inductor's lack of saturation of its current. It is also an indication that inductive impedance is failing to get in the way of current. So, there is no time lag for the current to rise or fall behind any sudden rise or fall of voltage. Instead, there is a time delay for the accumulation of reactive power to occur throughout the circuit.

Furthermore, this condition exhibits a lack of back EMF. Back EMF only occurs upon the saturation of an inductor. But if current and voltage are out of step with each other by one-half cycle of oscillations, then how can any saturation occur so long as voltage is never allowed to be tied to current in a causal relationship of current traveling as a consequence of voltage “pressure” driving current forward?

Instead, current does not travel; it merely points itself in one direction or another to indicate the consumption or the production of power at that particular location with respect to the orientation of voltage at each location. But these consumptions and productions do not occur. These are merely labels we pin to the characteristic behaviors of changing states of voltage within the valence electrons of conductive materials undergoing the conventional throughput of overwhelming voltage arising from a source which exceeds the impedance of the throughput's path. WARNING...These labels do not apply to a broken throughput. This is where the laws of physics breaks down.

To illustrate how fictional is the existence we ascribe to current, imagine a stadium filled with lots of people doing the “wave”. Certain people – at any point in time – stand up and sit down while raising or lowering their arms to accentuate their upward and downward movements. Up close, it looks like people standing up and sitting down. Yet at the other side of the stadium, it looks like a wave is rippling across the stadium in a direction which is perpendicular to the upward and downward movements of the audience.

This is the basis of a camshaft, or cam drive, mechanism found to be so familiar within locomotive steam engines and internal combustion engines in any standard automobile.

Professor Eric Laithwaite, of Imperial College at London, England, did some videos which are on YouTube. One of his videos<sup>2</sup> distinctly exhibits this phenomenon in which a series of rods moving up and down can create such a convincing illusion of movement rippling

1 “Mho's Law Justifies Free Energy” – figures, vol. 2 of 2: <https://www.amazon.com/dp/B098GM2LMQ/>  
Full text: <http://vinyasi.info/mhoslaw/Provisional%20Patent%20Application%20-%2063221840.pdf>

2 “Professor Eric Laithwaite: Magnetic River 1975” on YouTube at...  
[https://www.youtube.com/watch?v=OI\\_HFnNTfyU&t=607](https://www.youtube.com/watch?v=OI_HFnNTfyU&t=607) = <https://is.gd/onejuh>

sideways that it manages to “convince” a sphere to move along with the ripples! Energy has not been transferred and converted from reciprocating motion into rotary motion. Instead, data has communicated among the components of that setup to convince, and evince, a reaction among them in a coordinating manner. I call this: cooperation; not energy transfer.

Electricity is an indication of consciousness; of life responding to changes in its environment. And these responses result from an intelligence of reactivity which may negatively or positively impede a circuit. Since negative impedance generates reactive power and positive impedance consumes it, it is safe to say that reactance is an intelligent force to reckon with. On the other hand...

Any indication of throughput is *not* an indication of intelligence. Instead, it is an indication of brute force and its responsive consequence of submission to that brute force if the full amount of voltage is supplied to completely satisfy an “appliance” (load) by overcoming its various impedances.

## Chapter 2: What is Gravity versus Levity?

### And where do UFO's come from?

I, like William Lyne<sup>3</sup> before me, do not believe in aliens being responsible for UFO technology.

The technology is so simple, that Nikola Tesla figured it out while he was enrolled in university and then implemented its proof of concept around 1894.

He converted an aluminum potbelly stove into a one-man craft and tootled around the skyline of New York City at night from his lab atop a multistory hotel.

But, then, fate dealt a harsh blow to Tesla. For, in the following year of 1895, Germans stole all of his technology and hid the theft by instigating an arson of his lab.

Many devices were stolen, his: liquefaction of air, his Special Generator,<sup>4</sup> his UFO propulsion system, etc. We know this is true due to the patenting of one of his devices, the liquefaction of air, by a Carl Linde of Germany that same year after the fire destroyed his lab.

He never recovered from that event. Instead, he ignored all of those developments and moved on to others.

But, by 1903, he was commercially dead. No new invention of his ever made it to market. And for the next 40 years, until his death, he tinkered with many profitable ideas for which he could not find a backer (but not for lack of trying).

---

3 “Occult Ether Physics”, 4<sup>th</sup> revised and expanded edition: Tesla's Ideal Flying Machine and the Conspiracy to Conceal it, by William Lyne, <https://www.amazon.com/dp/0985452714/>

4 Part Two of Chapter 18 of William Lyne's book, “Pentagon Aliens”, <https://www.amazon.com/dp/0963746774/> and Chapter 43 of Thomas Commerford Martin's book, “The Inventions, Researches and Writings of Nikola Tesla”, <https://www.amazon.com/dp/1493646281/>

As he said of himself, “the world is not ready for me”. He belongs to the future.

---

Since the acceleration of an object, due to gravity, cannot be initiated by a electrostatic charge whose polarity is shared among the group of objects which are falling together, and because all objects generally share the same polarity of charge, it is impossible for electrostatics to explain gravity....unless.... stellar and planetary gravitational force is caused by an opposing charge located on the underside of every hollow star or hollow planet effectively rendering these hollow celestial objects into spheroidal and ellipsoidal capacitors.

All objects of opposing polarity of charge (measured in voltage potential) fall together. But celestial gravitational force is the result of buoyancy causing material objects of similar polarity of charge to repel each other and, thus, counteract the attraction which all planetary or stellar matter has towards the underside of their hollow shells. Thus, a hollow shell of a planet or star “floats”, ie. levitates, above its geometric center.

This is how a UFO manages to float above the surface of the Earth: by repelling itself from the Earth to the same degree as molecules of air at a similar altitude repel themselves from the surface of the Earth.

Whatever is the charge potential of neighboring molecules of air are equivalent to the polarity of charge of a UFO craft which is hovering at the same altitude as are those molecules of air, then at that altitude will both the neighboring molecules of air and a UFO craft hover alongside each other. The difference between them is in the frequency of reactive electrostatic voltage which is grounded out to the air molecules which are immediately adjacent to a UFO craft. This elevated frequency must compensate for the UFO craft's density.

Since the natural tendency of the materials (which are used to construct a UFO) will want to fall to the Earth to equalize their density of atomic number with that of the density of the atomic numbers of the materials which comprise the surface of the Earth, the UFO craft utilizes a different frequency more in alignment with materials which are denser than the materials at the surface of the Earth along with utilizing a polarity of charge which is more similar to that of the air molecules at a specific altitude rather than mimic the same charge potential as is found at the Earth's surface.

This will neutralize gravity, or buoyancy, and maintain the UFO's altitude.

These two factors of frequency (representing atomic density) and polarity of charge are not equal across the surface of the Earth. The Earth possesses a topography of differentiation which distributes these two factors in varying amounts across the surface of the Earth which makes it possible for a UFO craft to suddenly reorient itself from one location above the Earth's surface to another by suddenly altering its own frequency and electrostatic potential.

Even the Earth falls towards a raindrop. It's just that we don't see much movement in the Earth since the raindrop is so small possessing a minute charge potential. Instead of seeing movement in the Earth, we see movement occurring in the raindrop. Why? Because the raindrop appears to have less inertia than the Earth. But that is a false presumption.

If truth be told, the raindrop has less inertia because it has less mass. Yet, that mass is determined by its size as much as it is determined by its density.

The raindrop doesn't weigh less than the Earth due to the Earth having more mass than the raindrop. Nor is it because the Earth is more dense than the raindrop. It is because the Earth has a greater diameter than the raindrop. And if we were to judge the difference between two objects whose diameter were the same, then their difference of mass is determined by their frequencies.

Every object shakes; it wiggles in place. It doesn't go anywhere. Yet, its energy is expended in vibrating at a certain frequency and moving (ever so little) back and forth, or around and around a geometric center, which is the average point in space around which it is wiggling.

This tendency to vibrate overcomes inertia to a limited degree. It facilitates the movement of objects towards one another once the electrostatic force initiates this movement. Vibratory rates of: wiggling side to side, or around and around, throttles how fast an object will accelerate towards another object. So, objects are not dense. They are simply vibrating faster than objects which are considered to be less dense.

Consider this “vibration of objects” to be a “slippage factor”. For example...

Take quicksand, for instance.

If you wiggle your body while it is immersed in quicksand, you'll sink that much faster.

But if you remain perfectly still, you might survive long enough until help arrives to pull you out.

Again... During an earthquake, the water table can rise up and turn solid dirt into a sea of quicksand sinking everything, and everyone, into itself in a very short span of time.

This is what we misrepresent as the “density of an object” is really just its “rate of vibration” is faster than other material objects which wiggle a lot slower. So, it has a greater tendency to slip towards other objects since its faster rate of vibration facilitates a faster rate of slippage once the electrostatic force initiates a mutual falling together among a group of objects.

Inertia is not a property of matter. It is a property of space.

It is space which serves as a dielectric medium between any two objects storing a dielectric charge measured as a voltage difference between those two objects. Those two objects are where it becomes possible to measure the voltage which is stored within the empty space, or within any other dielectric medium, between any two objects. But those two objects do not store anything. They merely facilitate our ability to measure the charge which is stored inside the space between them.

It was Nikola Tesla, himself, who invented the vacuum tube capacitor. It did not become available as a commercial product until a year before he died.<sup>5</sup> Nonetheless, it proves the point wherein our silly notion as to where is a dielectric charge stored? It is not stored within the conductive plates surrounding a dielectric medium. Nor is it stored within matter. It is stored in the space between matter.

This empty charged state is called Prana, also known as the life force. But...

The life force is not a current. Current kills the life force.

And the life force is not voltage. Voltage stagnates the life force.

---

<sup>5</sup> Vacuum variable capacitor – Wikipedia, [https://en.wikipedia.org/wiki/Vacuum\\_variable\\_capacitor#Invention](https://en.wikipedia.org/wiki/Vacuum_variable_capacitor#Invention)

The life force is a dance conducted by two diametrically opposing forces whose differences are so contrasted that each is the other half of the other. These two forces are: the electromotive force and the magnetomotive force. Separately, they are life. Together, they are electricity which is death (electrocution) to living beings. In conclusion...

Just as the dielectric medium between the two plates of a capacitor is the only thing standing in the way of those two plates wanting to come together due to electrostatic attraction existing between them when the dielectric medium between them is storing a charge on their behalf, likewise does the dielectric medium of empty space initiates an inertial force which strives to prevent any two objects from initiating a movement towards one another. This inertial force (of space) has to be overcome if what we call gravity is to take effect and accelerate the movement of two objects to come together.

That's gravity defined from an electrical engineering point of view. Notice, there was little if any physics involved. Nor should there be any need for its involvement. Electrical engineering stands fairly stable on its own ground if left undisturbed.

---

So, how does a UFO defy gravity?

By initiating a very high frequency, but of a polarization of electrostatic charge which is opposed to that of the Earth, namely: a positive charge. And if the UFO wants to submerge itself beneath water, it merely flips its polarity to that of being a negative electrostatic charge, yet, still maintain its high frequency of throwing away reactive electrostatic charge in huge quantities to its immediate surroundings.

This is how it neutralizes inertia. By neutralizing the gravitational (ie, electrostatic) influence of heavier objects nearby, such as: the Earth, by mimicking the frequency of much heavier objects than the Earth so as to fly around independent of the Earth's gravitational/electrostatic influence.

For, the Earth's gravitational signature is determined by merely two factors:

1. Its average frequency (which we misinterpret as density), and...
2. Its polarity of electrostatic charge, which is negative.

The Coulomb force is what gives credence to mass. This is why the equation for the Coulomb force is almost exactly similar to that of the gravitational force. Their only difference is the gravitational constant is different than the Coulomb constant. Otherwise, they're exactly the same...

$$|F| = K \times \frac{|q_1 \times q_2|}{r^2}$$

“F” is the Coulomb force of electrostatic attraction/repulsion.

“K” is Coulomb's constant =  $8.988 \times 10^9 \text{ N} \cdot \text{m}^2 \cdot \text{C}^{-2}$

“q<sub>1</sub>” and “q<sub>2</sub>” are the signed magnitudes of the two charges.

“r” is the distance between them. The squaring of “r” indicates that this distance is a pair of vectors.

Compare this with Sir Isaac Newton's gravitational equation...

$$F = G \times \frac{m_1 \times m_2}{r^2}$$

“F” is the gravitational force between two objects, or the electrostatic force between two objects of opposite charges.

“G” is the gravitational constant  $\approx 6.674 \times 10^{11} \text{ m}^3 \cdot \text{kg}^{-1} \cdot \text{s}^{-2}$

“m<sub>1</sub>” and “m<sub>2</sub>” are the magnitudes of two masses.

“r” is the distance between them. The squaring of “r” indicates that this distance is a pair of vectors.

Wilhelm Reich got himself jailed, and all of his American publications burned, and his assassination just before being released from federal prison all because he downed a UFO craft.

If he hadn't ran towards the remnants of the downed craft hoping to find, and help, any of its survivors, he would not have run into the military who showed at the crash site at the same time and promptly arrested him.

He brought down the UFO craft using a device known as his set of rainmaking tubes. The front end of his tubes were open and he could direct towards clouds to evaporate them, for them, move them around the sky at will, and make it rain. The back end of his tubes were connected via conduit to a moving body of water.

On that fateful day, he pointed his tubes towards a cloud he was intending to dissolve. As it dissolved, it became apparent that there was a UFO at its center.

The UFO had been creating a cloud of positively ionized water vapor surrounding itself, both to hide itself as well as levitate itself above the negatively charged potential of the surface of the Earth.

The tubes connected with the dielectric lines of electrostatic force emanating from out of the UFO craft and passed the electrostatic charges of these lines of dielectric force to ionize the water molecules. As fresh water replaced the ionized water moving past his grounded conduit, electrostatic charge was pulled out of the immediate vicinity surrounding the UFO craft and, thus, neutralizing its electrostatic suspension which had been holding it above the Earth.

## **Appendix**

# ***Free Energy is the Non-Saturation of Inductor Current***

## ***Managing the Generation of Reactive Power for its Free Energy***

The Cosine of  $0^\circ$  is a Power Factor of +1 indicating a useful condition of the Consumption of Real Power at its maximum percentage of Positive Wattage.

The Cosine of  $90^\circ$  is a Power Factor of Zero indicating a useless condition of Real Power and its Conversion into Reactive Power.

Thus, the Sine of  $90^\circ$  yields a Leading Power Factor of +1 indicating a useful condition of Reactive Power Generated by Capacitive Reactance.

As with the Cosine of  $90^\circ$ , a Cosine of  $270^\circ$  is a Power Factor of Zero indicating another useless condition of Real Power.

But the Sine of  $270^\circ$  yields a Lagging Power Factor of  $-1$  indicating a useful condition of Reactive Power Consumed by Inductive Reactance.

The simultaneous occurrence of the Sine of  $90^\circ$  along with the Sine of  $270^\circ$  results in a Power Factor of Zero and yields an angular phase difference of the Sine of  $180^\circ$  indicating a useless condition of Reactive Power and its Conversion into Real Power. Its analogous Cosine of  $180^\circ$  indicates a phase separation between the voltage and the current waveforms of an oscillating wave and the Generation of Negative Watts. FYI, Negative Watts is the Passive Sign Convention's definition for Generators and Batteries<sup>1</sup> and could just as easily be applied to *any* Generation of Negative Watts by *any* Reactive Component, such as: Inductors or Spark Gaps, instead of merely applicable to Sine Wave Generators and Batteries.

Two resistors fed by a battery is an example<sup>2</sup> of the distinction between the generation of real power versus its consumption and satisfies the Conservation of Kinetic Energy upheld by physics...

---

1 "Passive Sign Convention" [https://en.wikipedia.org/wiki/Passive\\_sign\\_convention](https://en.wikipedia.org/wiki/Passive_sign_convention)

2 <http://vinyasi.info/hogwash/test/>



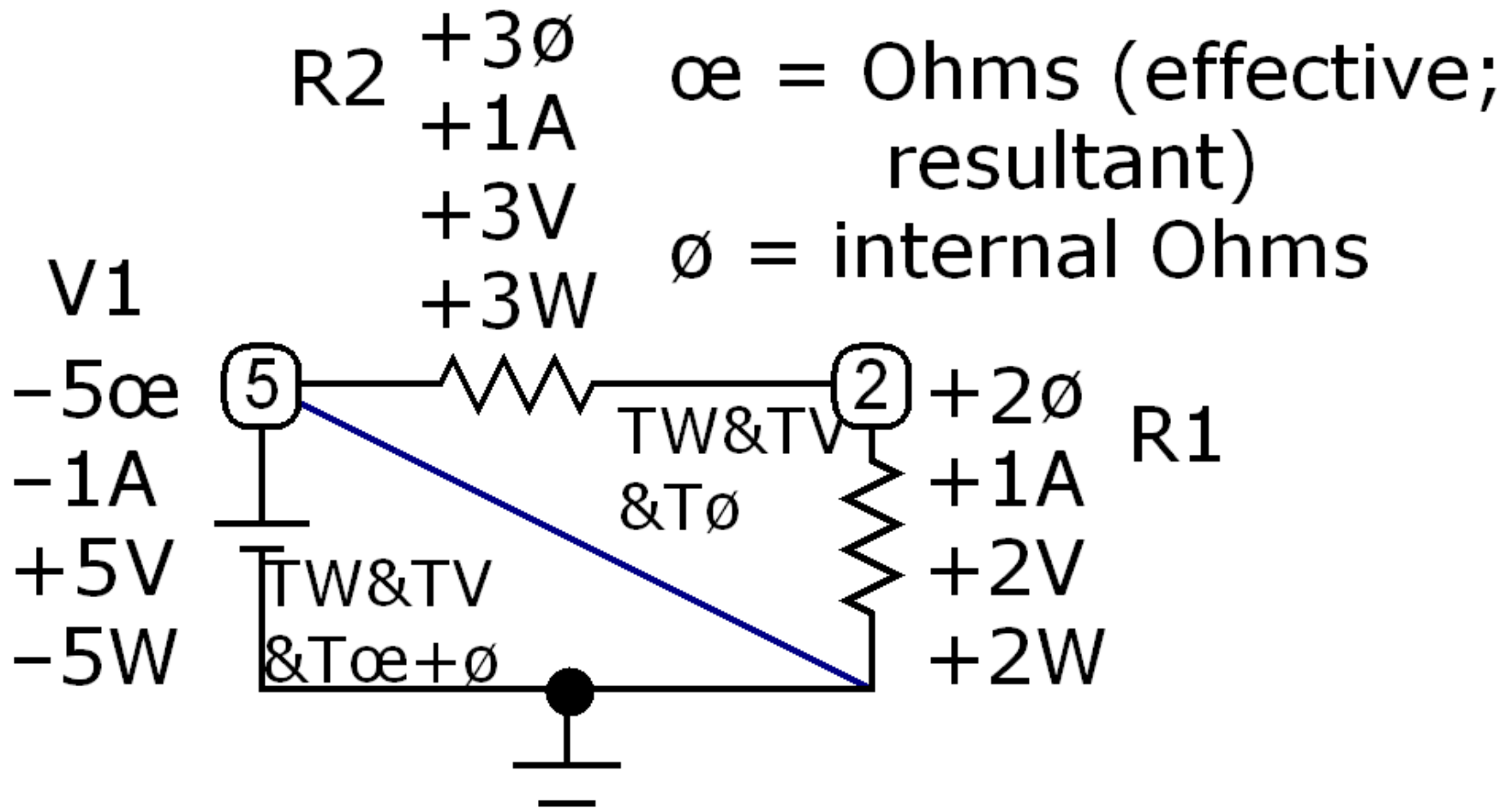

Fig. 1: Schematic of two Resistors fed by a Battery

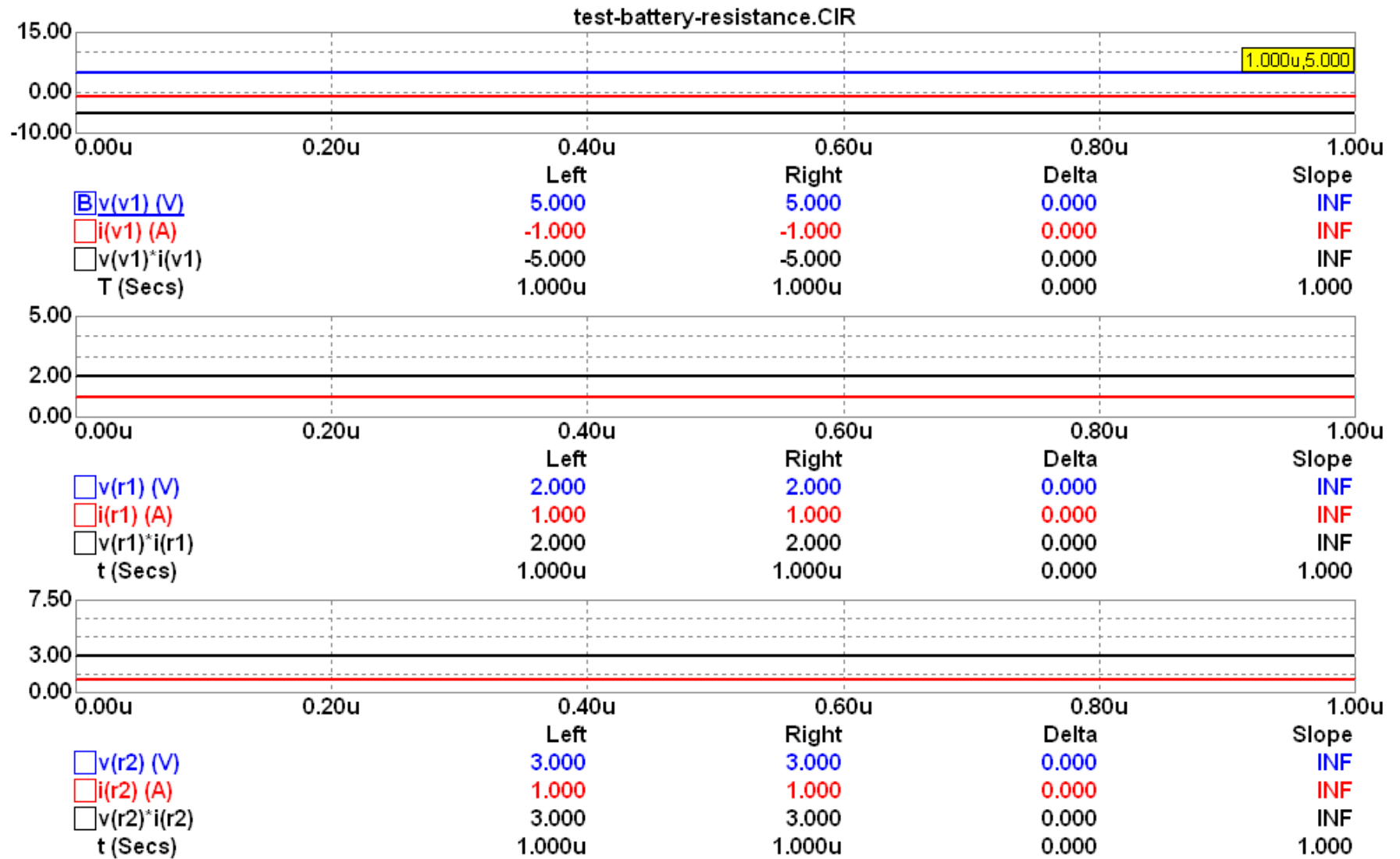

Fig. 2: Output of two Resistors fed by a Battery

When one of its resistors is replaced by an inductor...

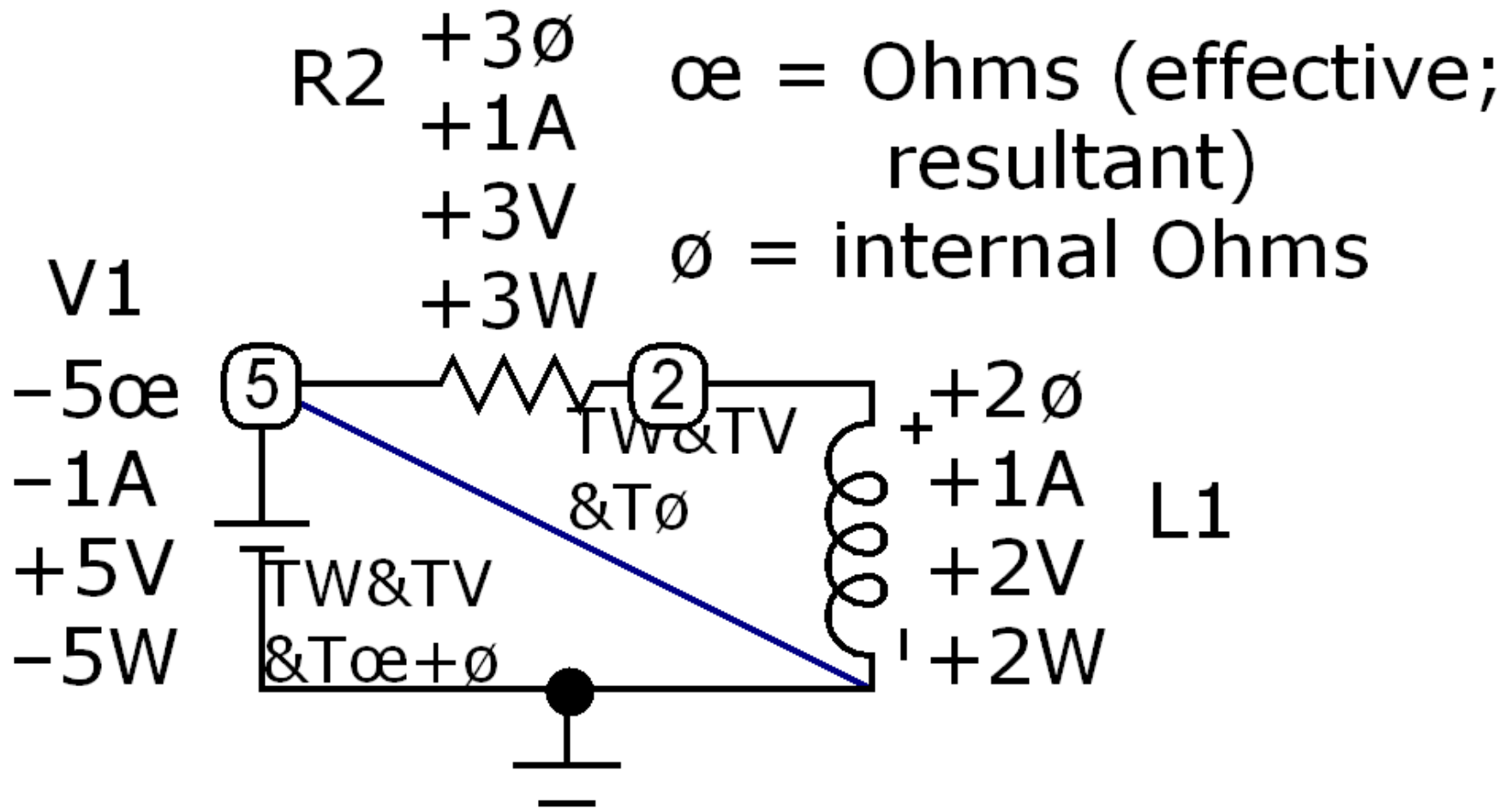

Fig. 3: Schematic of One Resistor and One Inductor fed by a Battery

...the result is exactly the same as if the resistor had not been replaced by an inductor – as per, Figures 1 and 2, above...

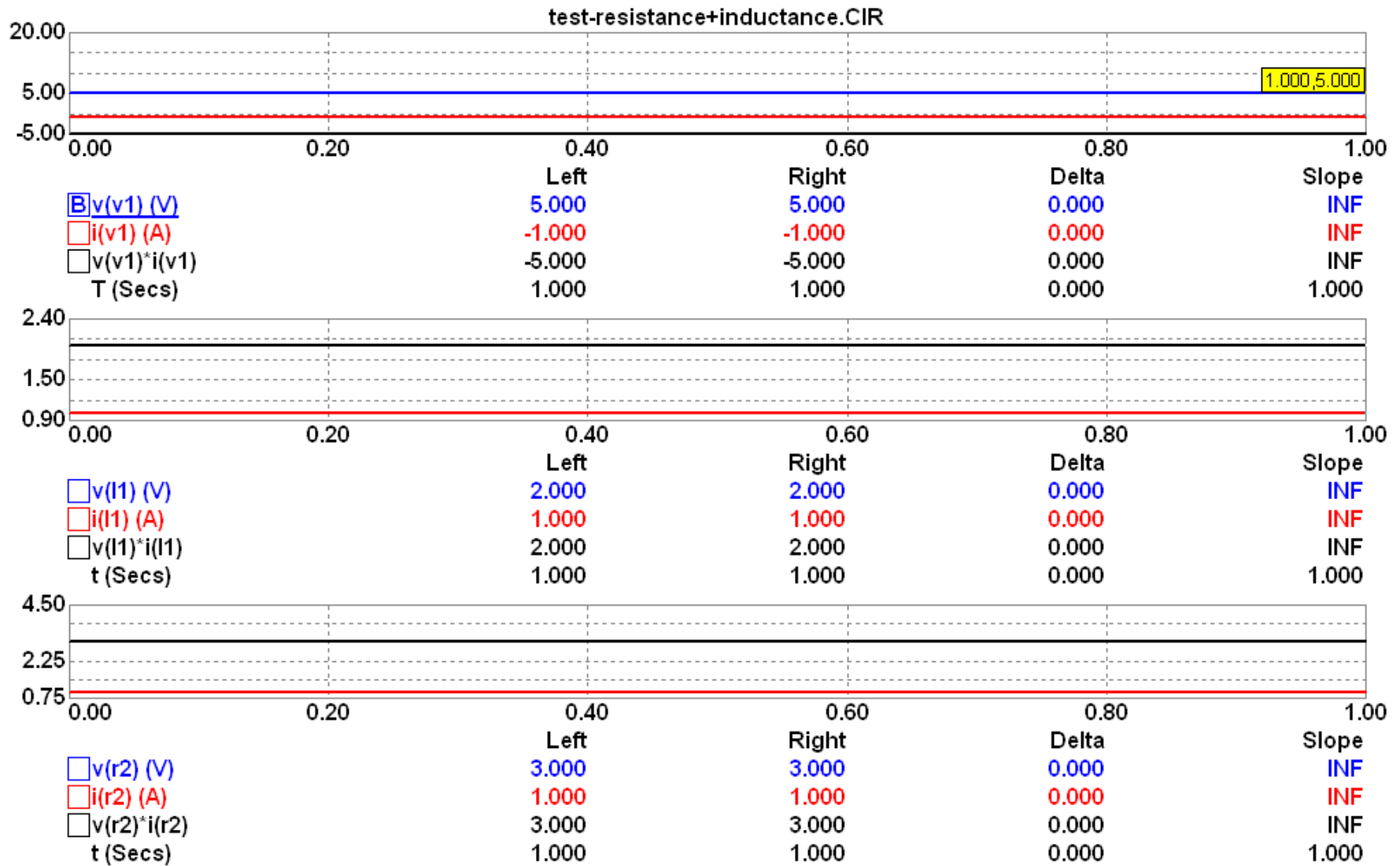

Fig. 4: Output of One Resistor and One Inductor fed by a Battery

It starts to get interesting when a sine wave voltage source replaces the battery...

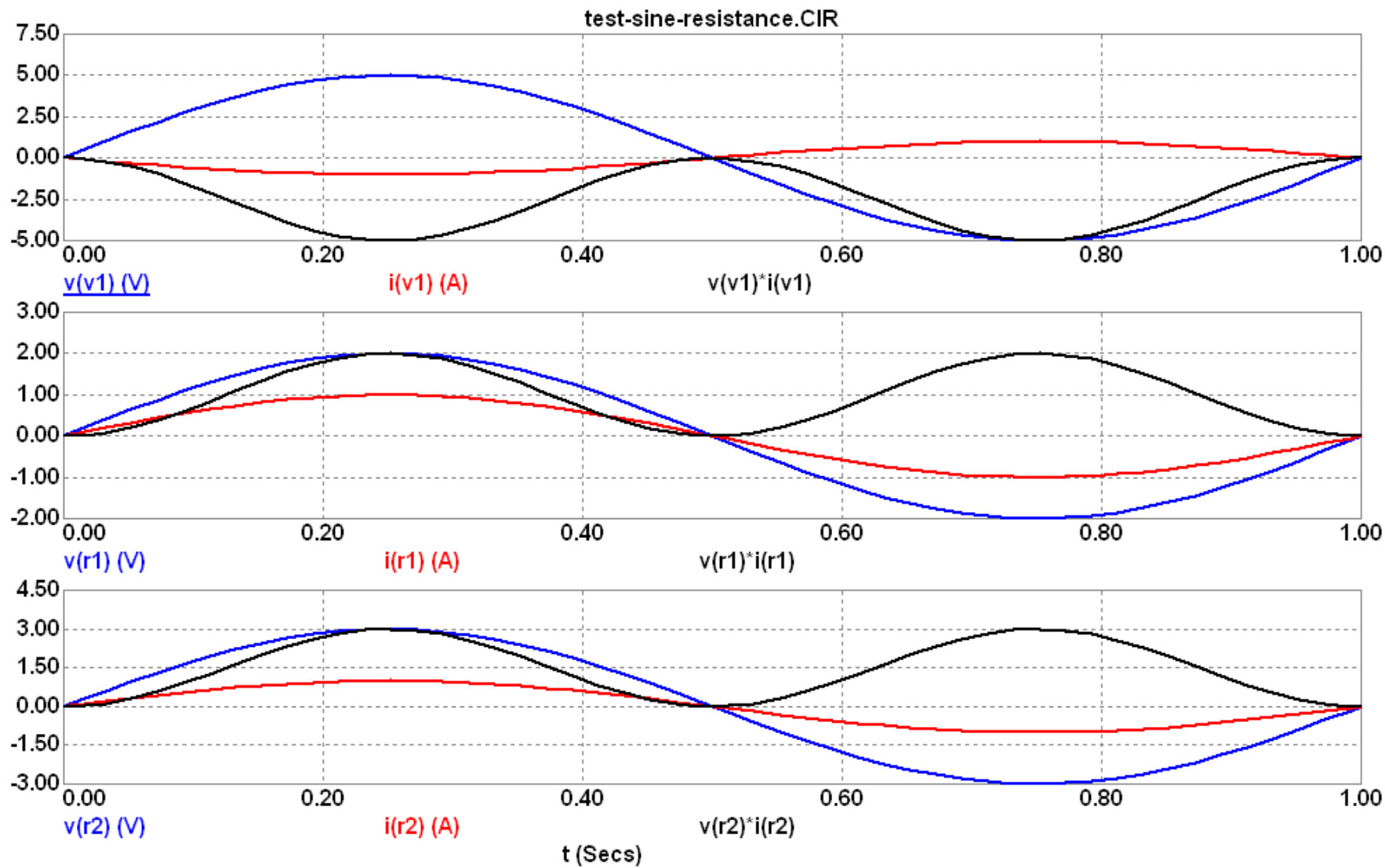

Fig. 5: Output of Two Resistors fed by a Sine Wave Voltage Source.

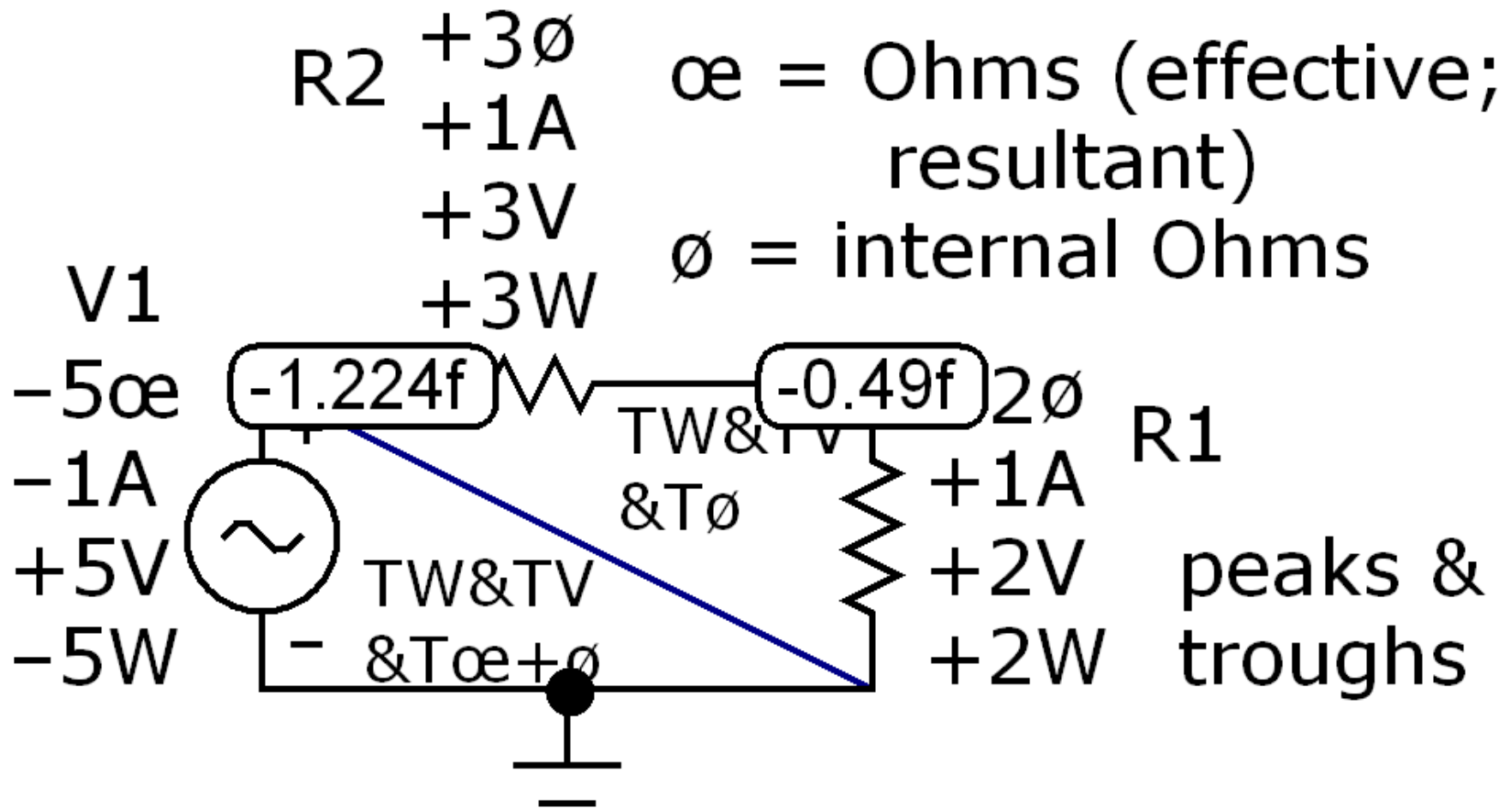

Fig. 6: Schematic of Two Resistors fed by a Sine Wave Voltage Source.

There is a slight momentary surge of current and a rise of voltage in an inductor/resistor load fed by a sine source...

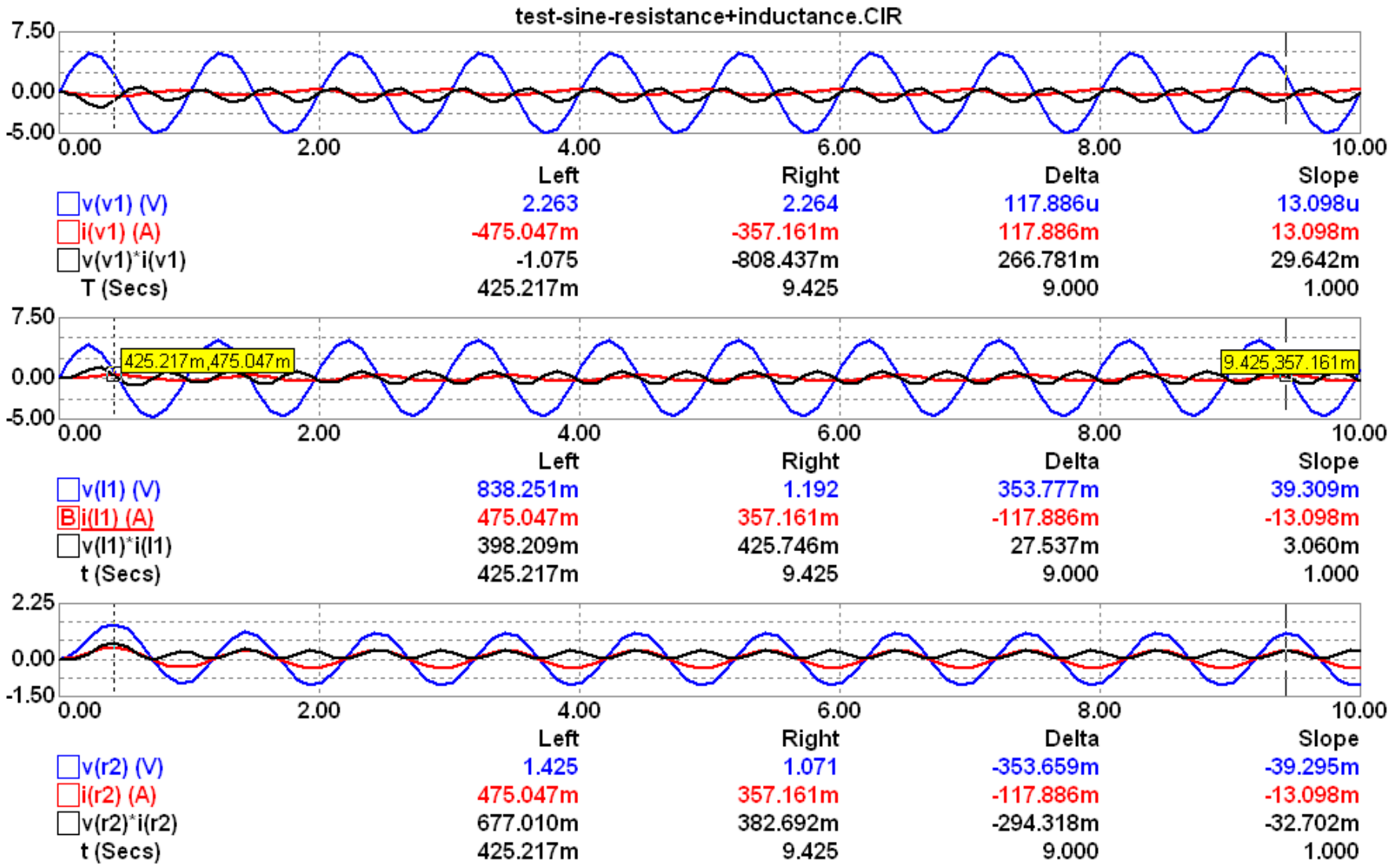

Fig. 7: Numeric Output of One Resistor and One Inductor fed by a Sine Wave Voltage Source.

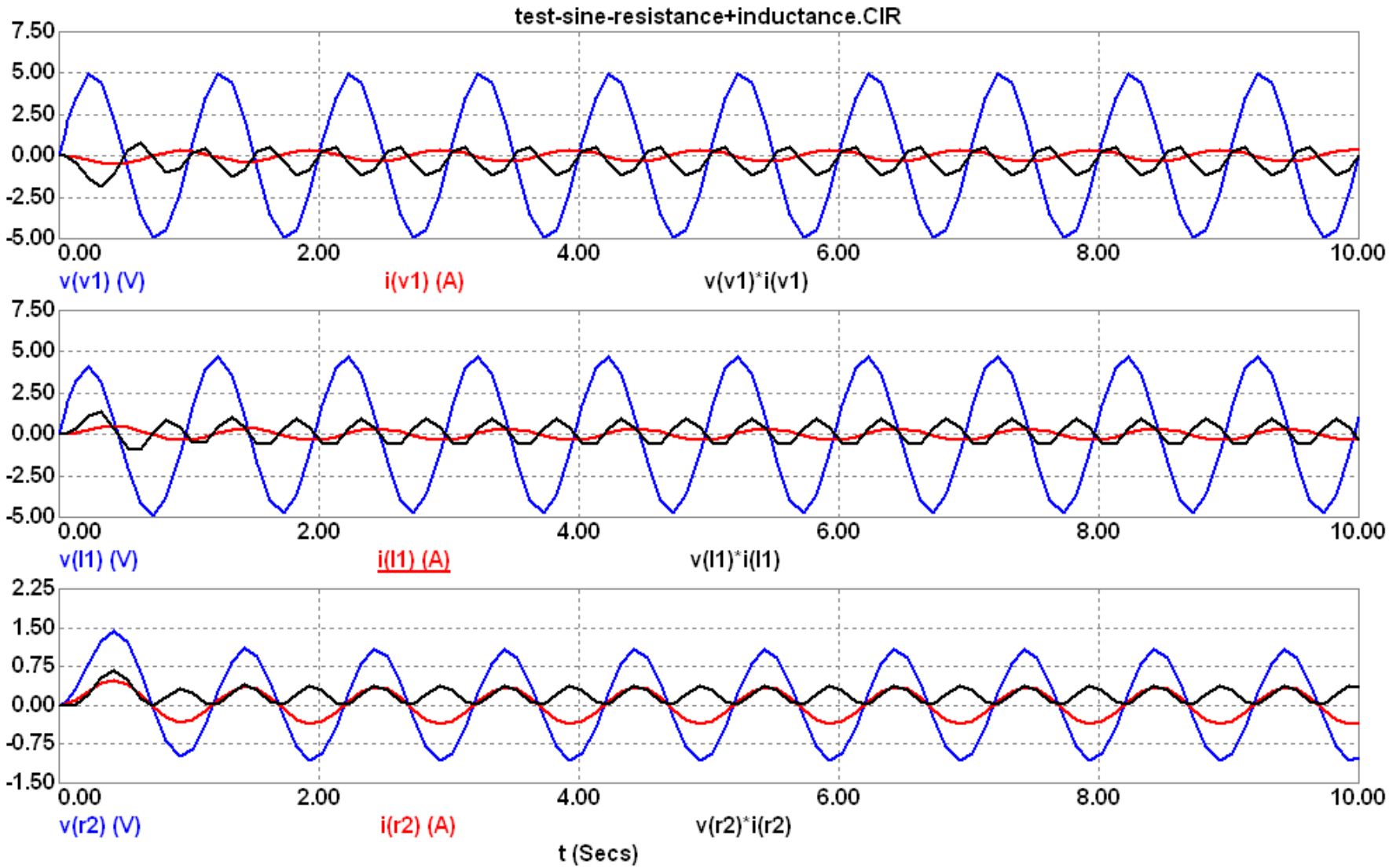
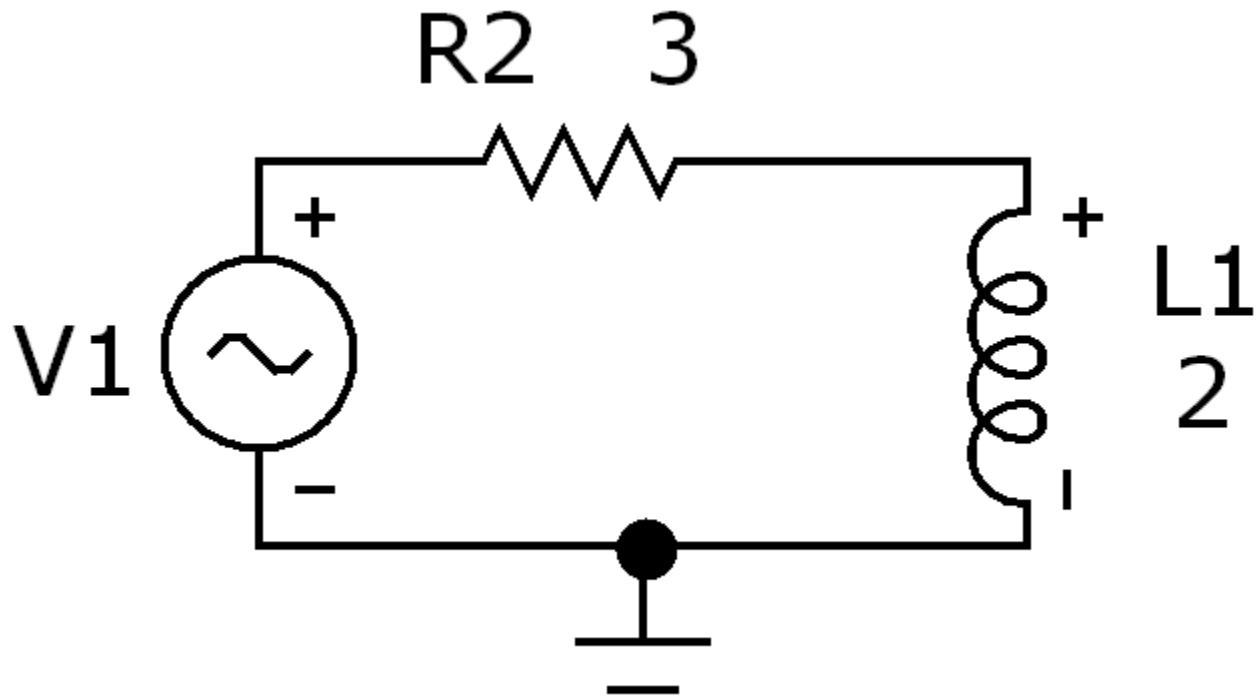

Fig. 8: Graphic Output of One Resistor and One Inductor fed by a Sine Wave Voltage Source.





*Fig. 9: Schematic of One Resistor and One Inductor fed by a Sine Wave Voltage Source.*

The demonstration of a leading current versus a lagging current is considered to be indication of capacitive reactance versus inductive reactance, respectively. But this is only true when current has reached saturation...

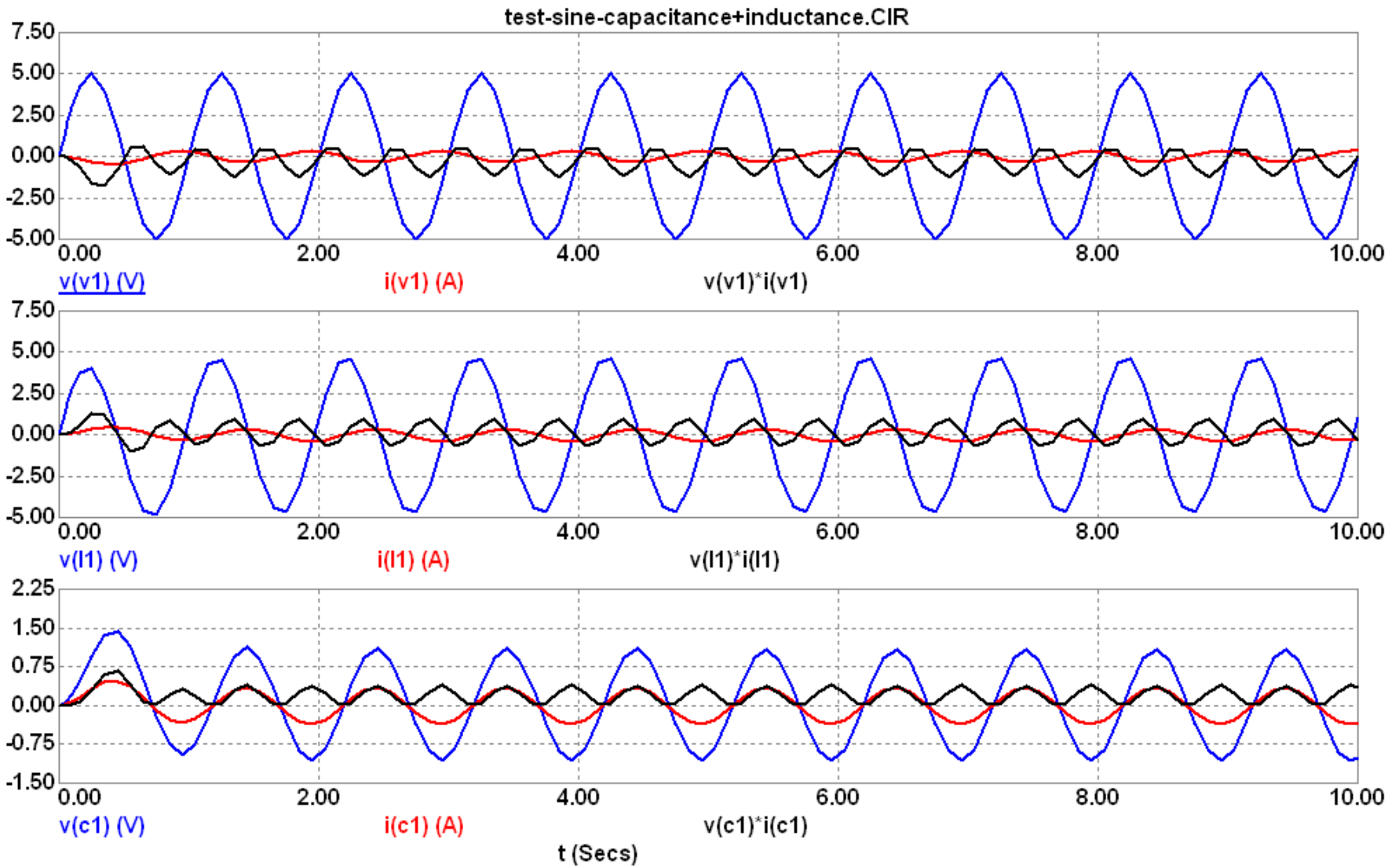
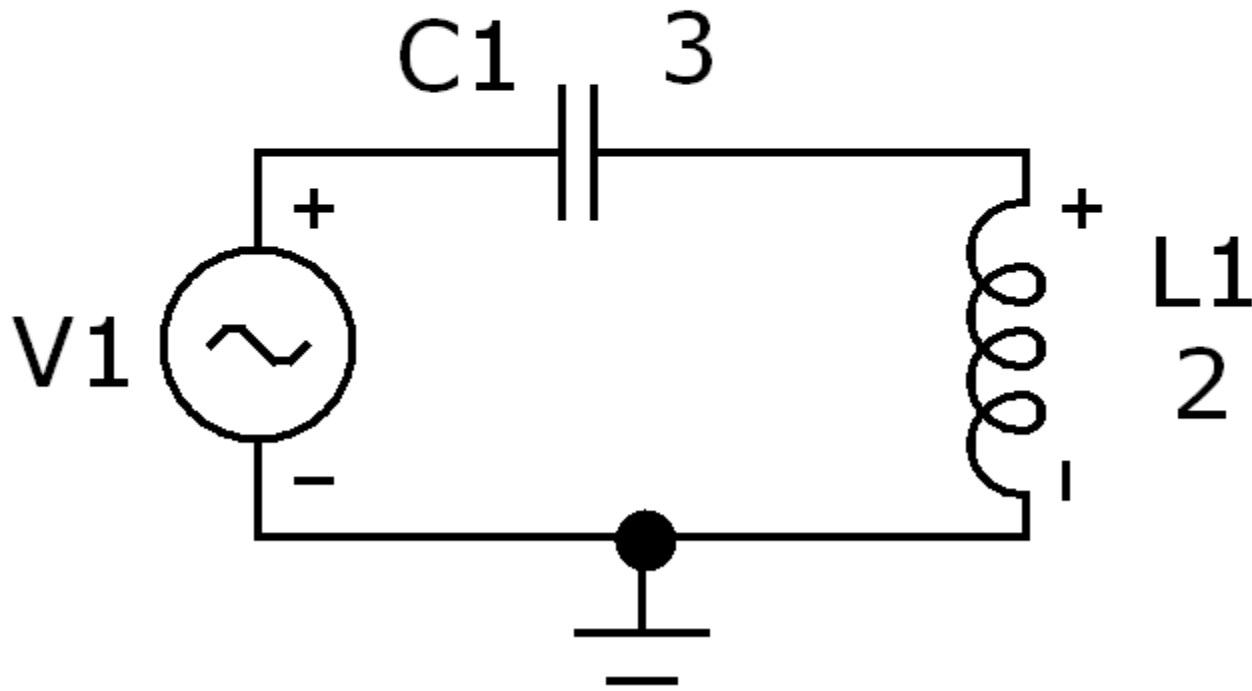

Fig. 10: Output of One Capacitor and One Inductor fed by a Sine Wave Voltage Source.

Inductors possess back EMF,  
Capacitors possess forward EMF,  
But only after current saturation.



*Fig. 11: Schematic of One Capacitor and One Inductor fed by a Sine Wave Voltage Source.*

It's really true what electrical engineering says about capacitive reactance generates reactive power. Its current doesn't merely lead its voltage by  $90^\circ$ . The polarity of the sign of voltage (positive versus negative) versus the polarity of the sign of current are opposite to each other indicating a condition of negative wattage and the generation of reactive power. Meanwhile, inductive reactance consumes reactive

power due to its voltage and current polarity of signs are the same as each other. But these conditions are only true whenever the phase of voltage and the phase of current are not out-of-phase with each other by a half-cycle of oscillation ( $180^\circ$ )...

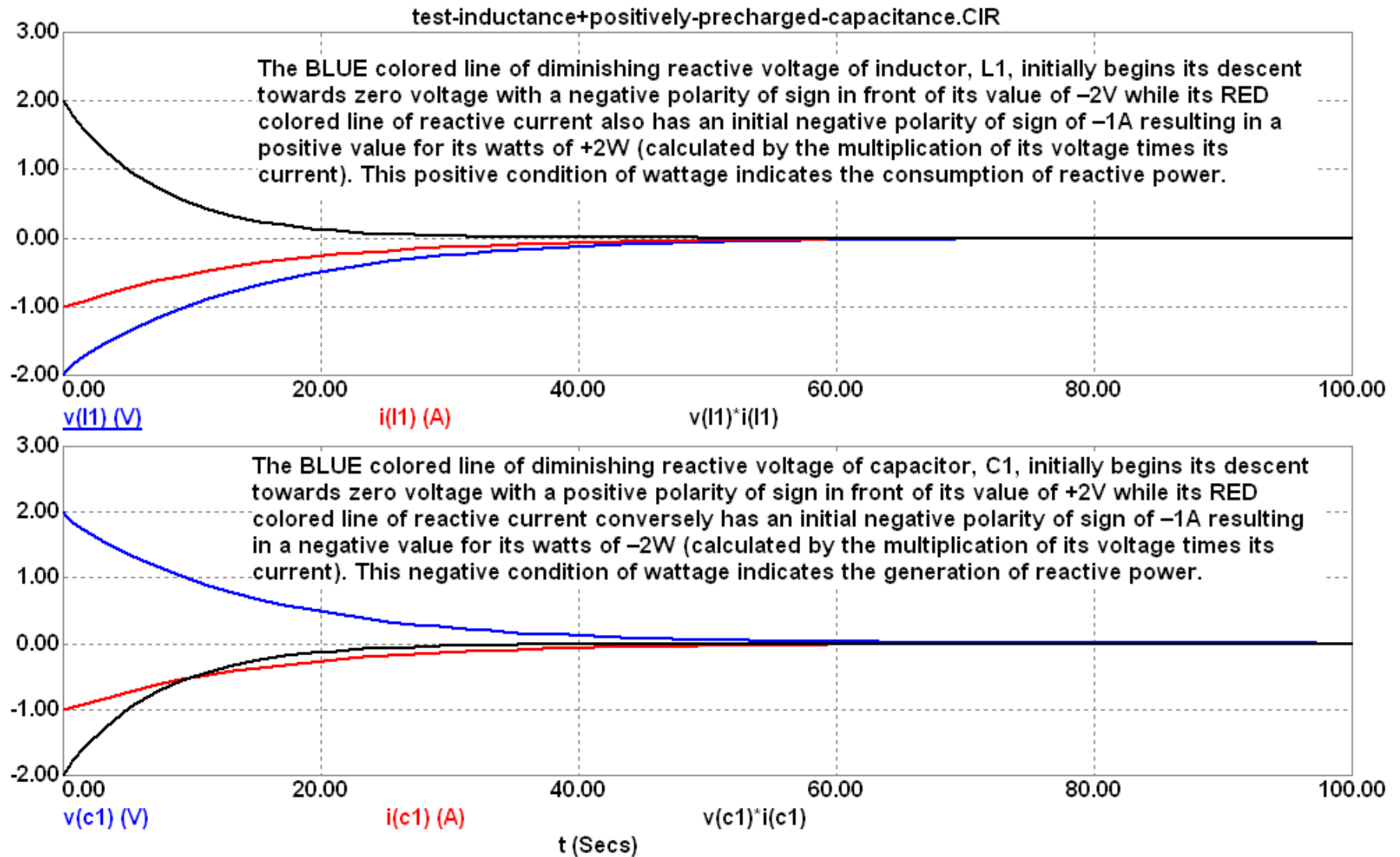
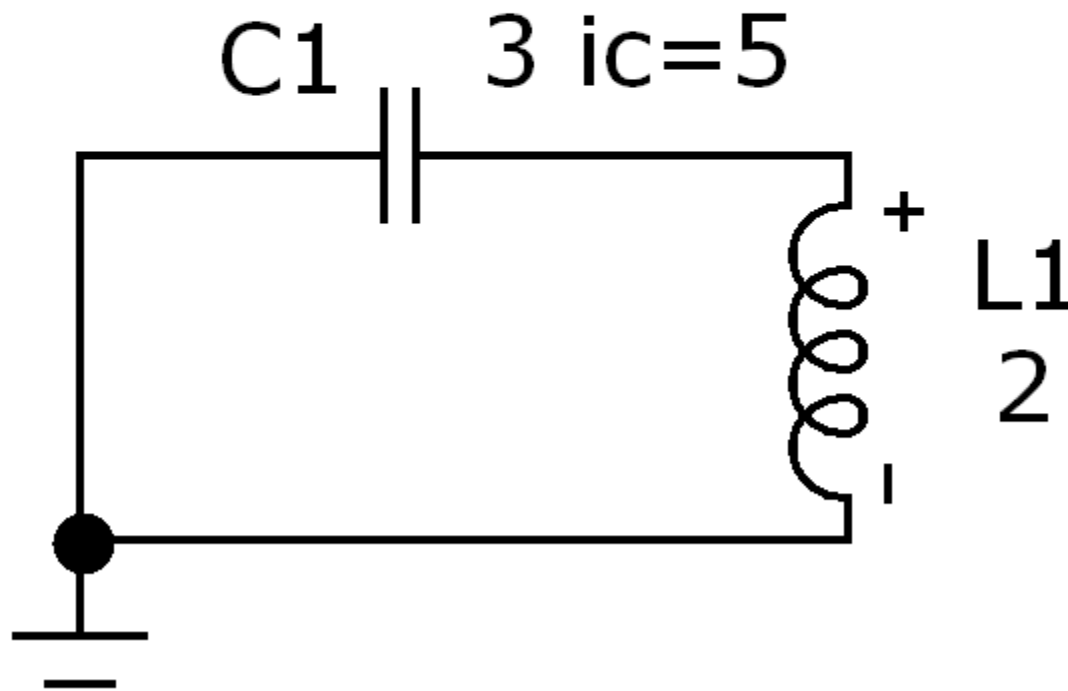

Fig. 12: Output of One Capacitor, Precharged with Five Volts, and One Inductor.

Capacitors generate negative wattage,  
Inductors consume positive wattage,  
And both diminish towards zero  
outputs when merely a tank circuit.



*Fig. 13: Schematic of One Capacitor, Precharged with Five Volts, and One Inductor.*

It doesn't matter if the capacitor is precharged with negative volts. The result is the same in both instances (above and below)...

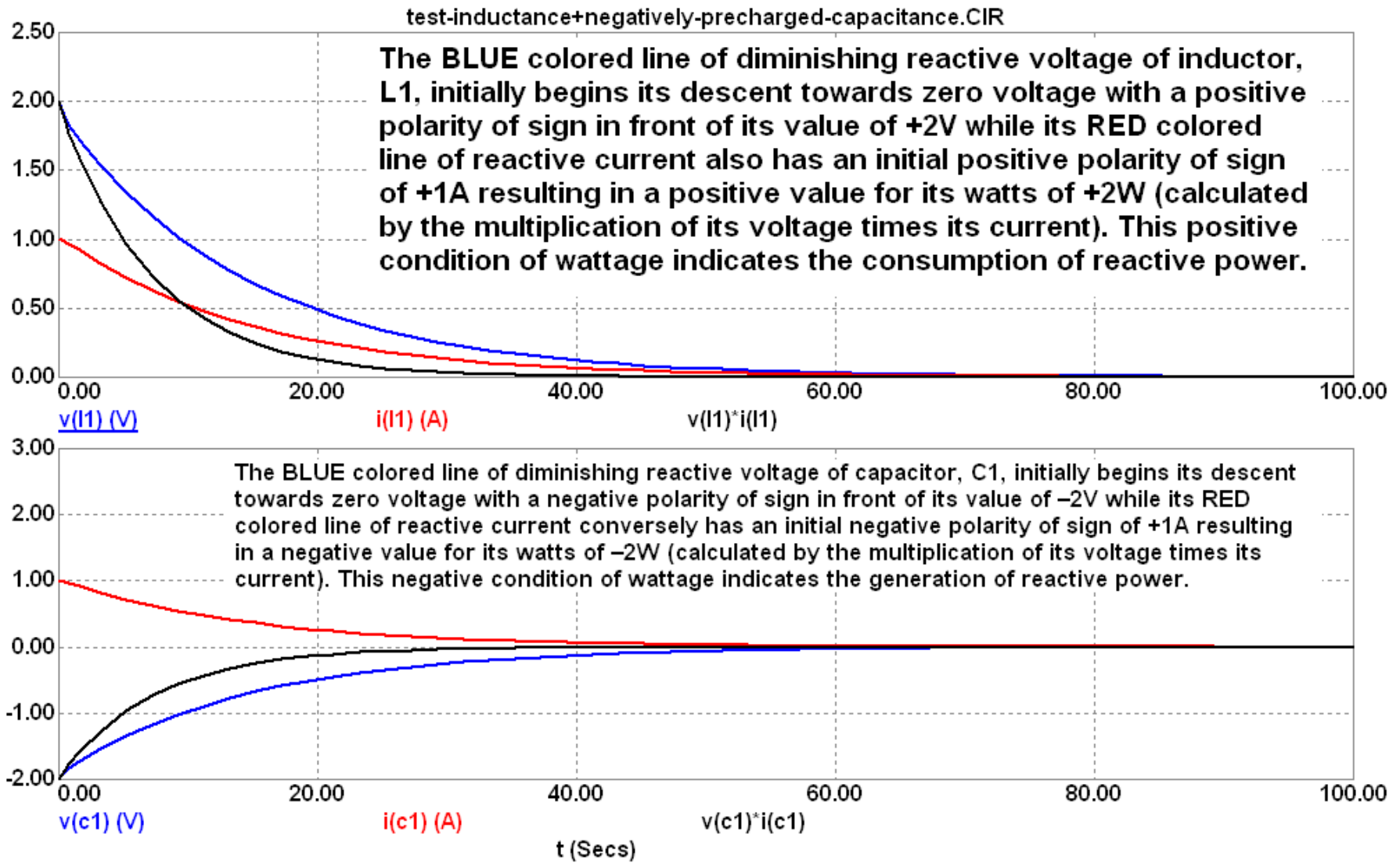
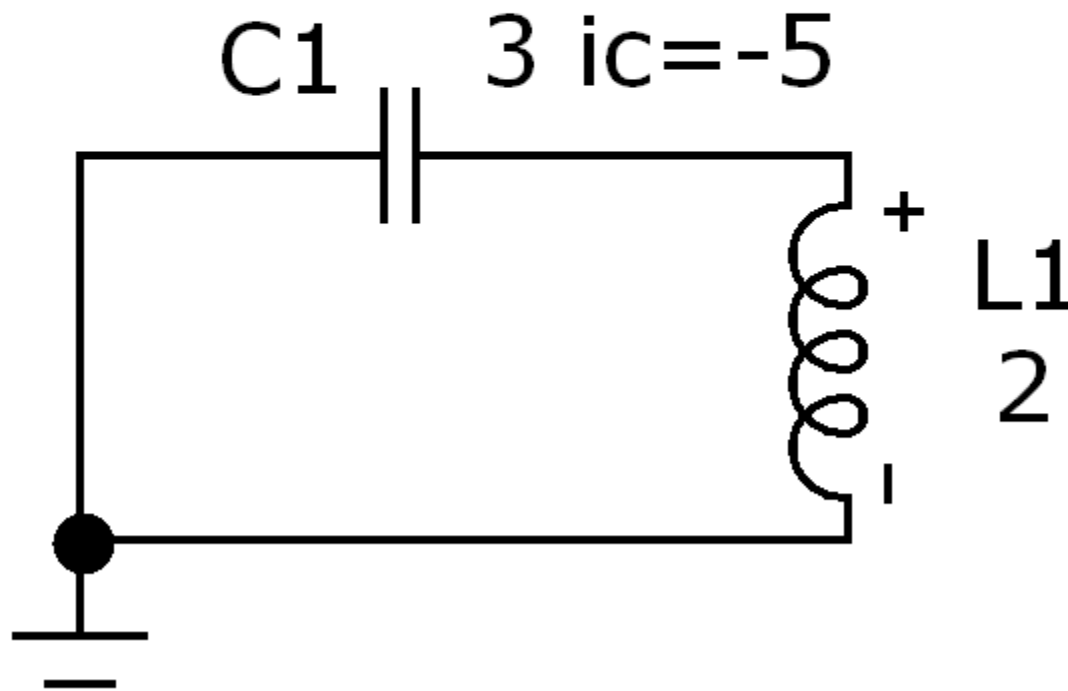

Fig. 14: Output of One Capacitor, Precharged with Negative Five Volts, and One Inductor.

Capacitors generate negative wattage,  
Inductors consume positive wattage,  
And both diminish towards zero  
outputs when merely a tank circuit.



*Fig. 15: Schematic of One Capacitor, Precharged with Negative Five Volts, and One Inductor.*

Doubling the capacitors and doubling the inductors alters nothing. Yet, this hints at the high percentage of the reuse of power to which I

am developing this presentation...  $A \text{ Percentage of the Infinite Reuse of Power} = \left(1 - \frac{INPUT}{OUTPUT}\right) \times 100 \text{ percent}$

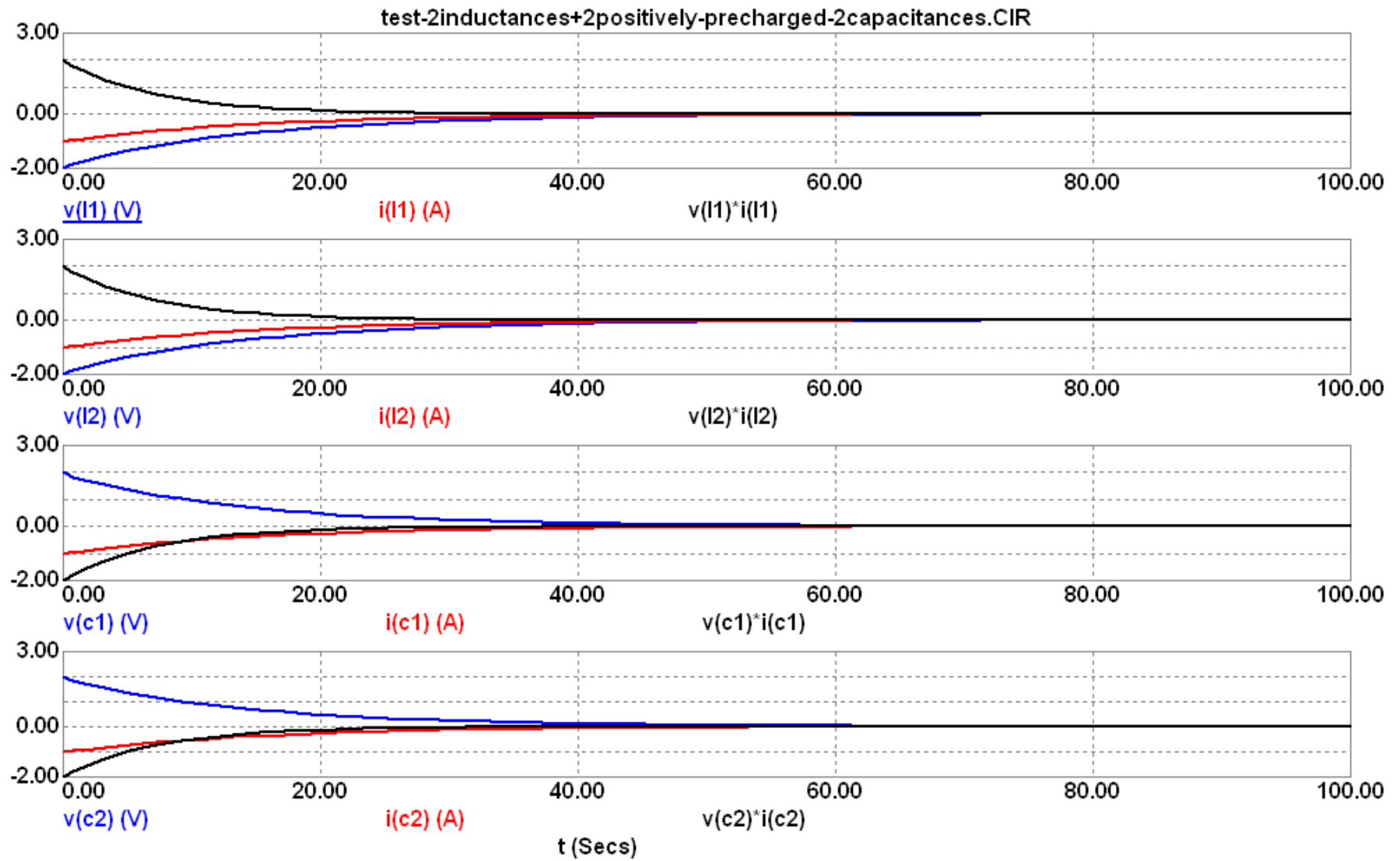

Fig. 16: Output of Two Capacitors, each Precharged with Five Volts, and Two Inductors.



Capacitors generate negative wattage,  
 Inductors consume positive wattage,  
 And both diminish towards zero  
 outputs when merely a tank circuit.

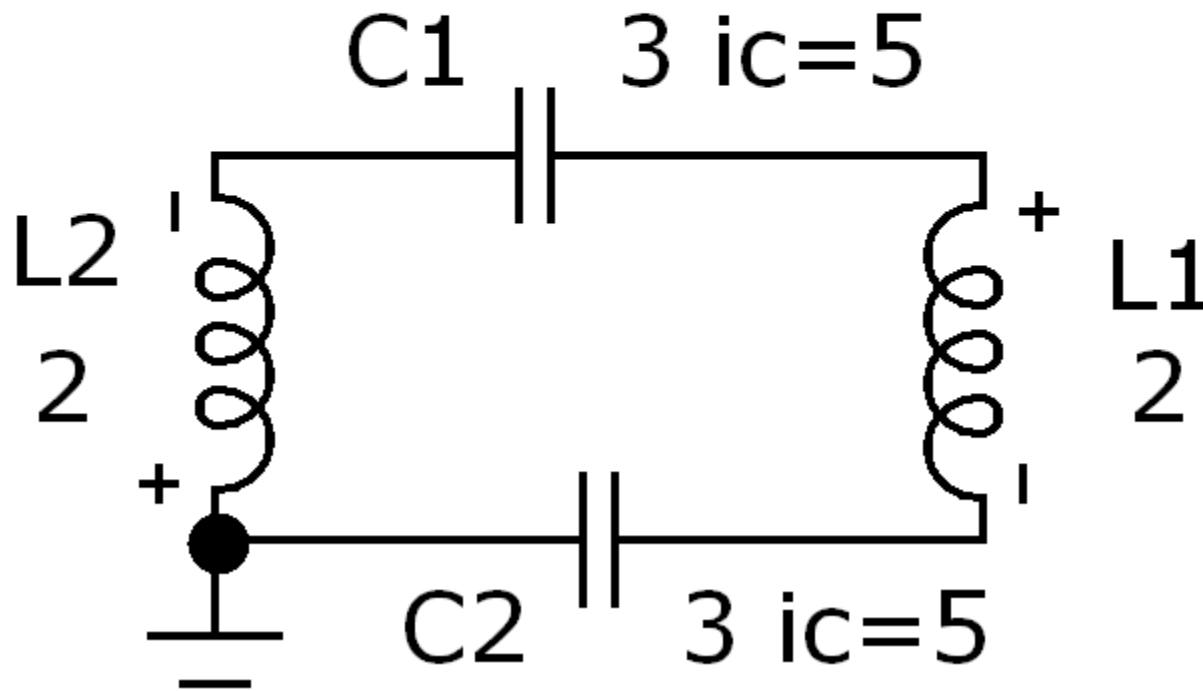

Fig. 17: Schematic of Two Capacitors, each Precharged with Five Volts, and Two Inductors.

**Triangular Waves are an Indication of Back EMF and the Failure of an Inductor to Saturate Itself with Current.<sup>3</sup> This Provides for the Possibility of the Escalation of Reactive Power without Limit. This Limitless Escalation Constitutes “Free Energy”.**

---

<sup>3</sup> “How to Avoid Inductor Saturation in your Power Supply Design”  
<https://www.monolithicpower.com/en/how-to-avoid-inductor-saturation-in-your-power-supply-design>

The triangular waves of this initial output looks promising,...

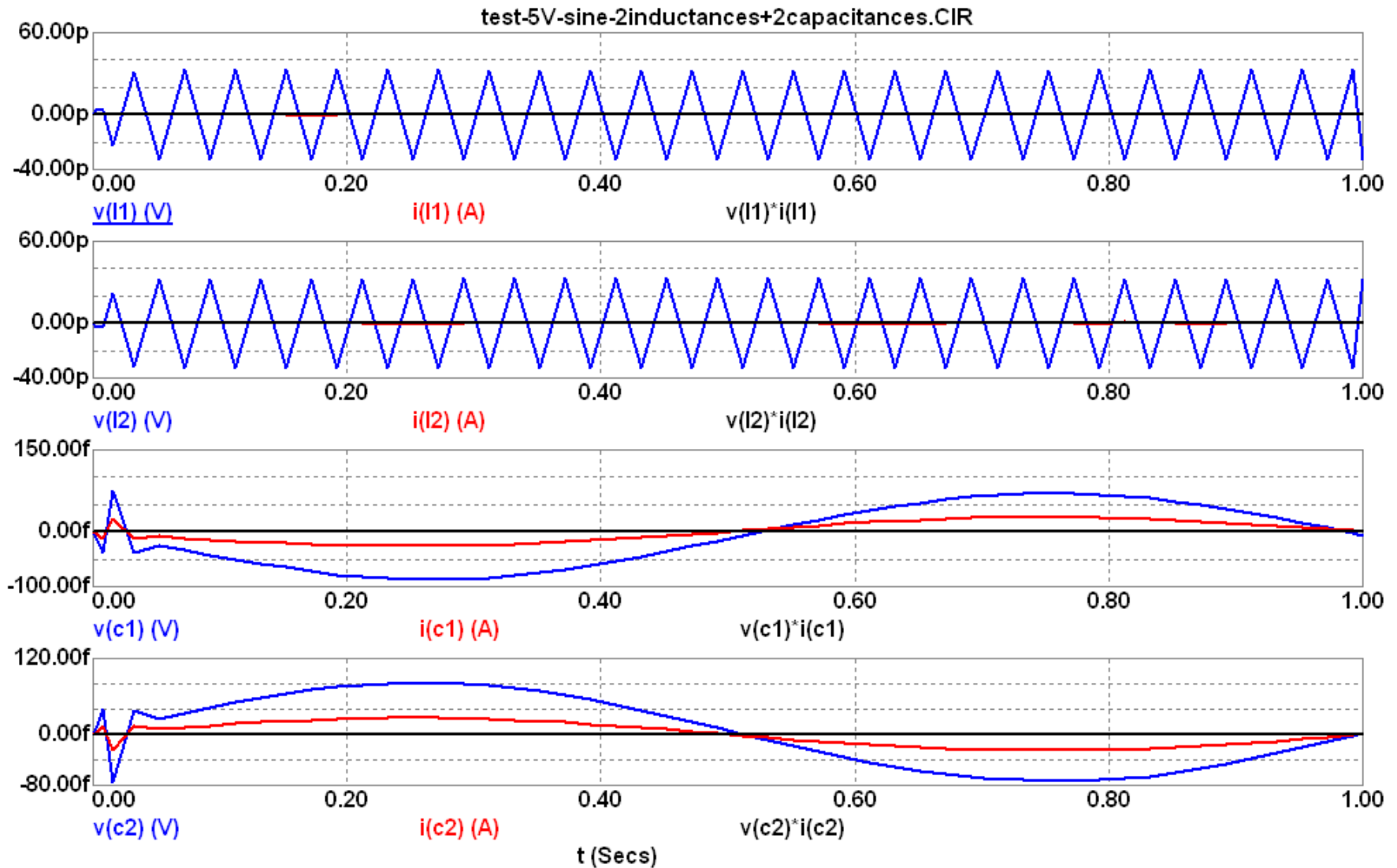

Fig. 18: One second output of Two Capacitors, Two Inductors and One 5V @ 1Hz Sine Wave Generator.

...but I wouldn't want to wait around to see what happens...

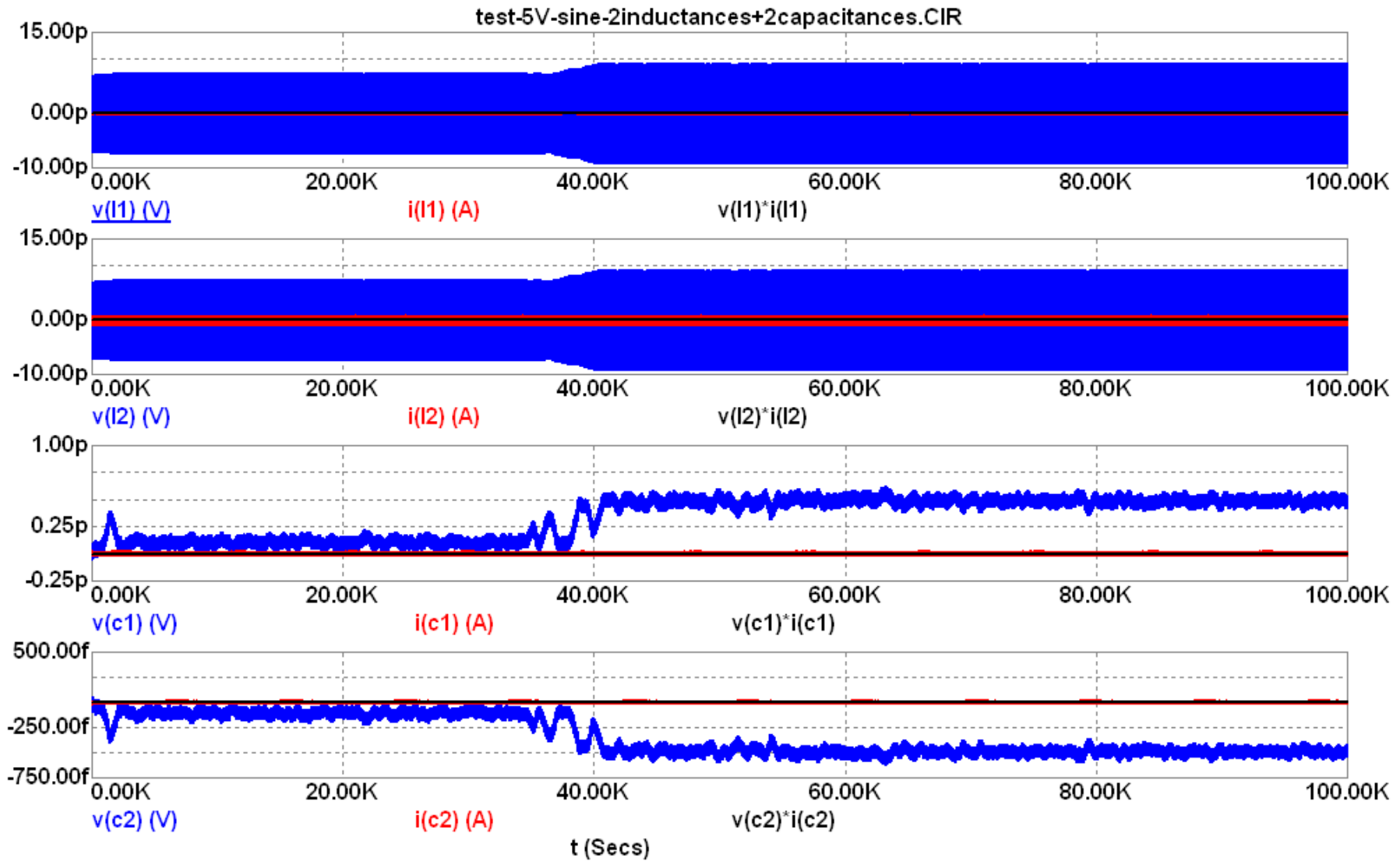
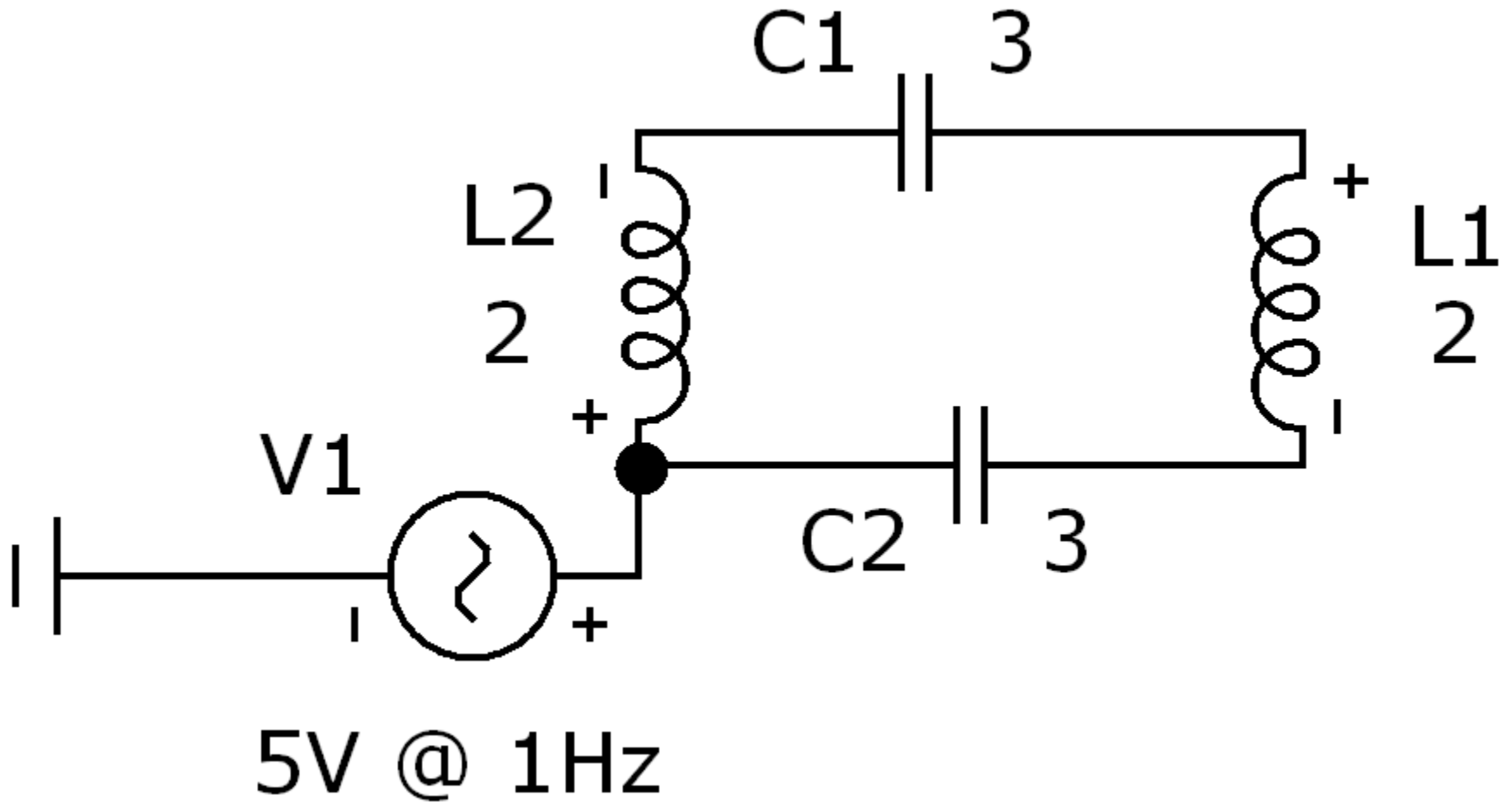

Fig. 19: 100 kilo-second Output of Two Capacitors, Two Inductors and One 5V @ 1Hz Sine Wave Generator.

Here is its schematic...



*Fig. 20: Schematic of Two Capacitors, Two Inductors and One 5V @ 1Hz Sine Wave Generator.*

Here is another initial output...

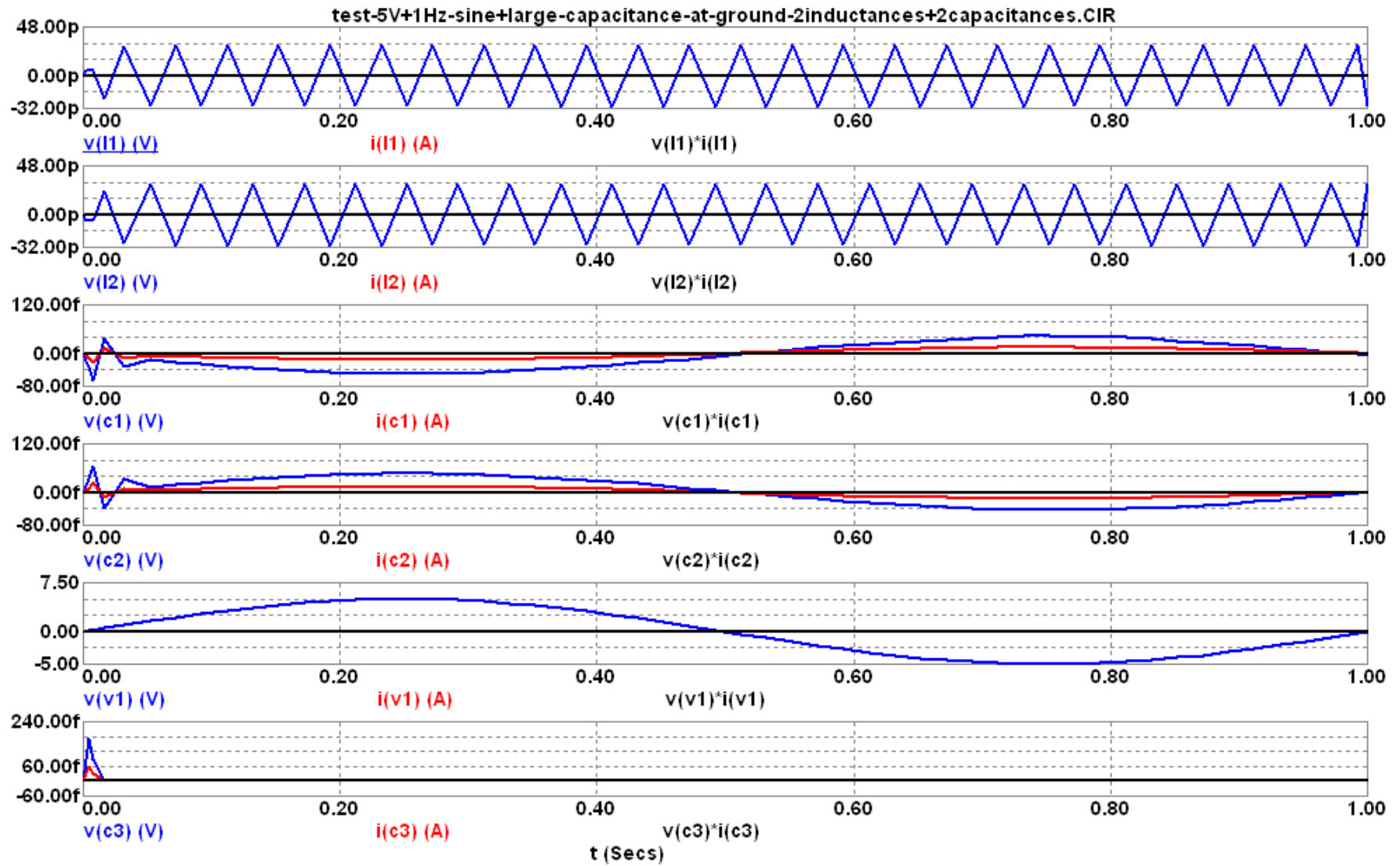
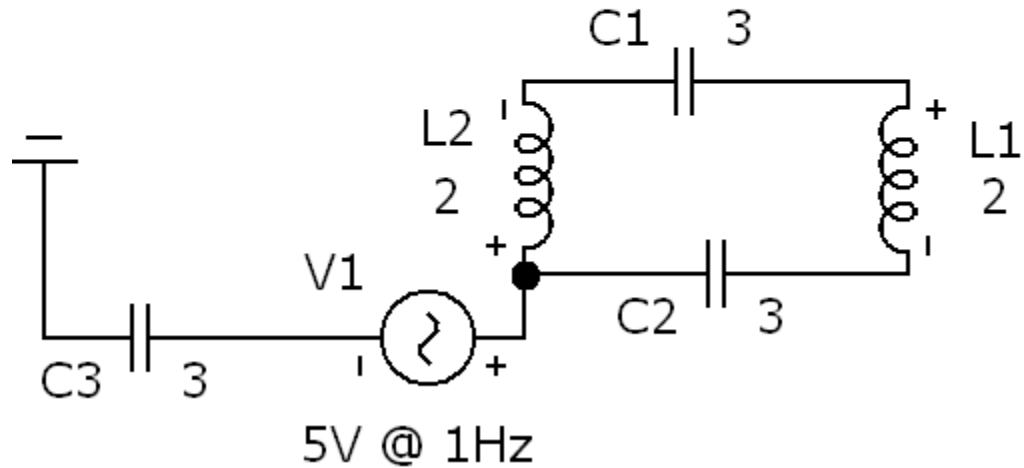

Fig. 21: Initial Output of Two Capacitors, Two Inductors and One Capacitor between Ground and a 5V @ 1Hz Sine Wave Generator.

...of another similarly long wait-time. And here is its schematic...

Inductors possess a triangular waveform of voltage due to their back EMF indicating that they never saturate with current when fed by a sine wave generator.



*Fig. 22: Schematic of Two Capacitors, Two Inductors and One additional Capacitor between Ground and a 5V @ 1Hz Sine Wave Generator.*

This shows promise for amassing lots of voltage *and not much else* reminiscent of a modern-day version of a Tesla Transformer,...

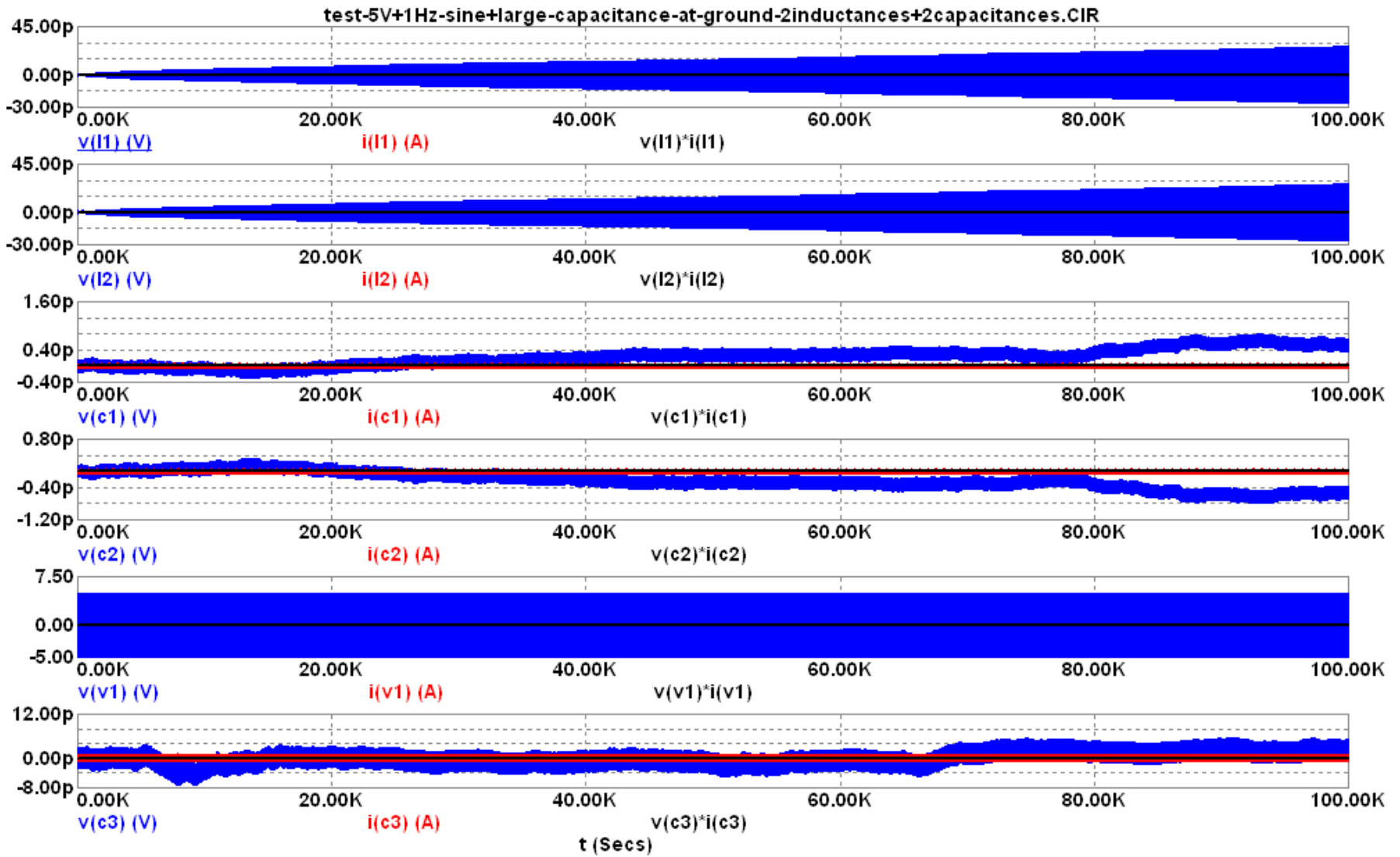

Fig. 23: Schematic of Two Capacitors, Two Inductors and One additional Capacitor between Ground and a 5V @ 1Hz Sine Wave Generator.

...but like before (at Fig. 19), I don't want to wait around for a noticeable gain of voltage! Looks like I'll have to share one more...



Coupled inductors possess a triangular waveform of voltage only at first due to their transient back EMF indicating that they quickly saturate with current when fed by a sine wave generator.

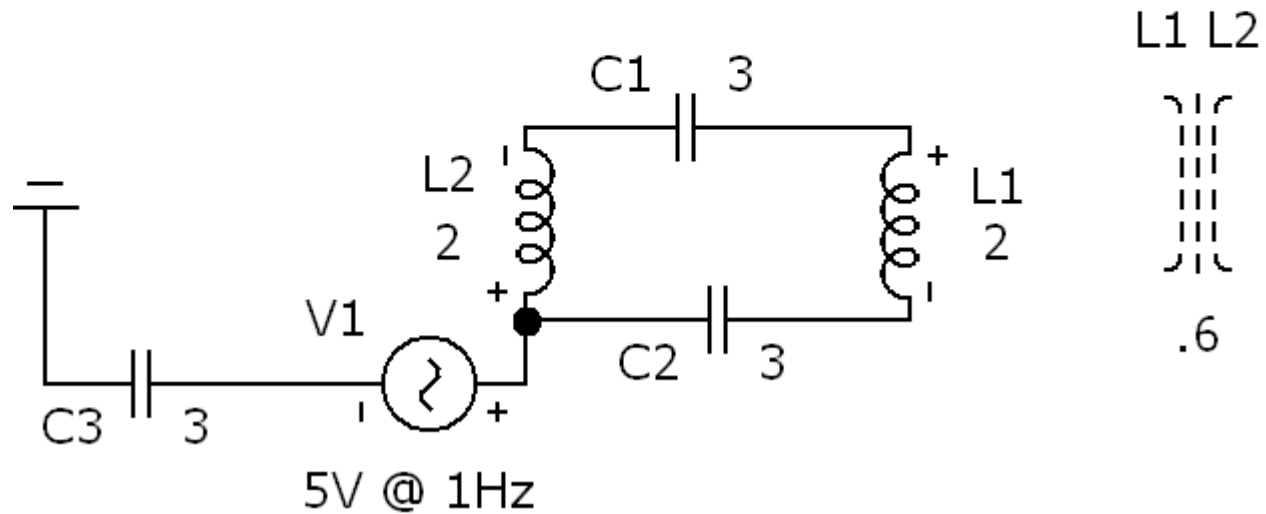

Fig. 24: Schematic of Two Capacitors, Two Coupled Inductors and One additional Capacitor between Ground and a 5V @ 1Hz Sine Wave Generator.

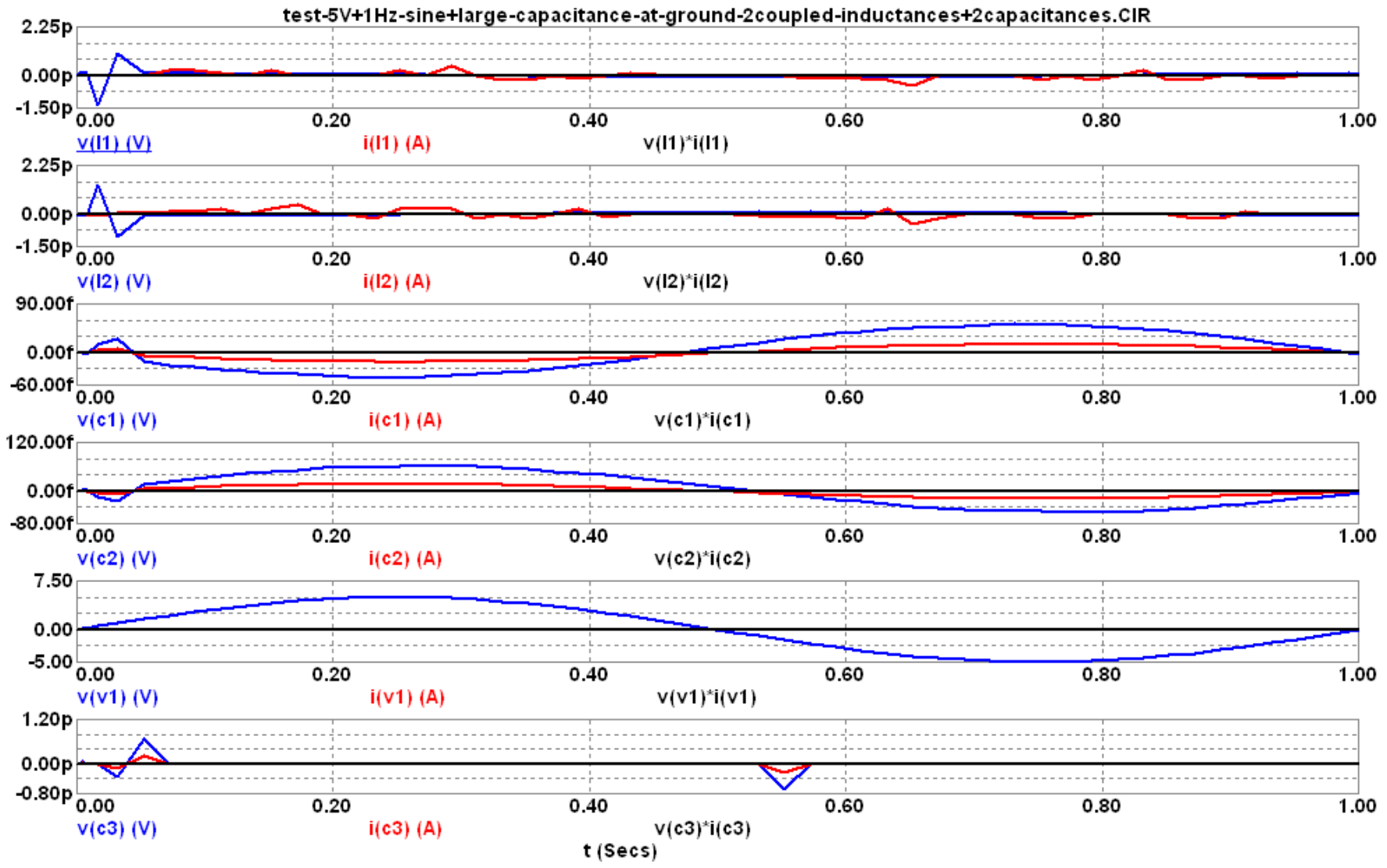

Fig. 25: One Second Output of Two Capacitors, Two Coupled Inductors and One additional Capacitor between Ground and a 5V @ 1Hz Sine Wave Generator.

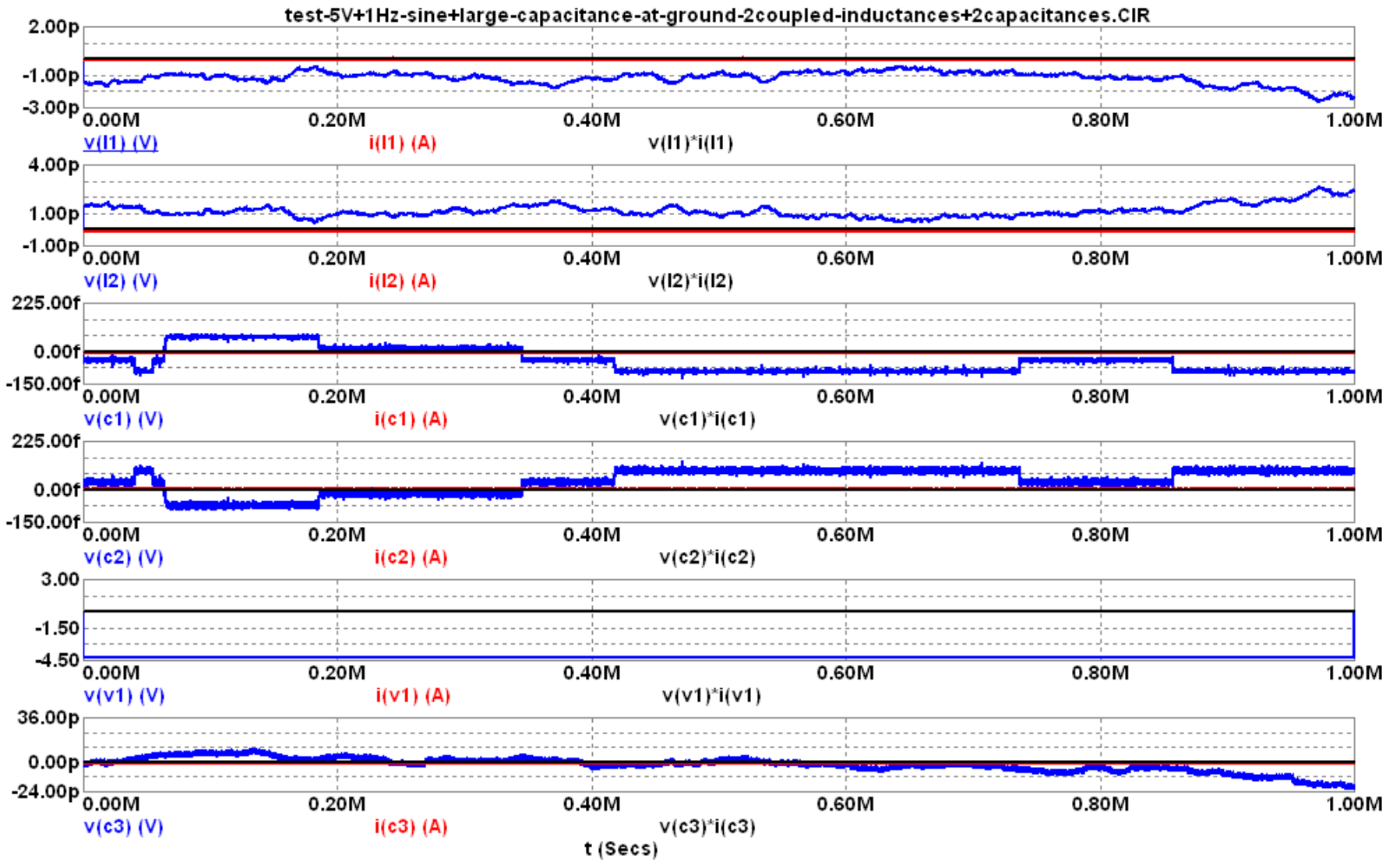

Fig. 26: One Million Seconds of Output of Two Capacitors, Two Coupled Inductors and One additional Capacitor between Ground and a 5V @ 1Hz Sine Wave Generator.

Now, why would I want to torture you with these boring results. To make a point. Sometimes, if you don't have a technique, all you can hope for is to raise the input frequency...

Coupled inductors possess a triangular waveform of voltage due to their back EMF indicating that they refuse to saturate with current when fed by a sine wave generator.

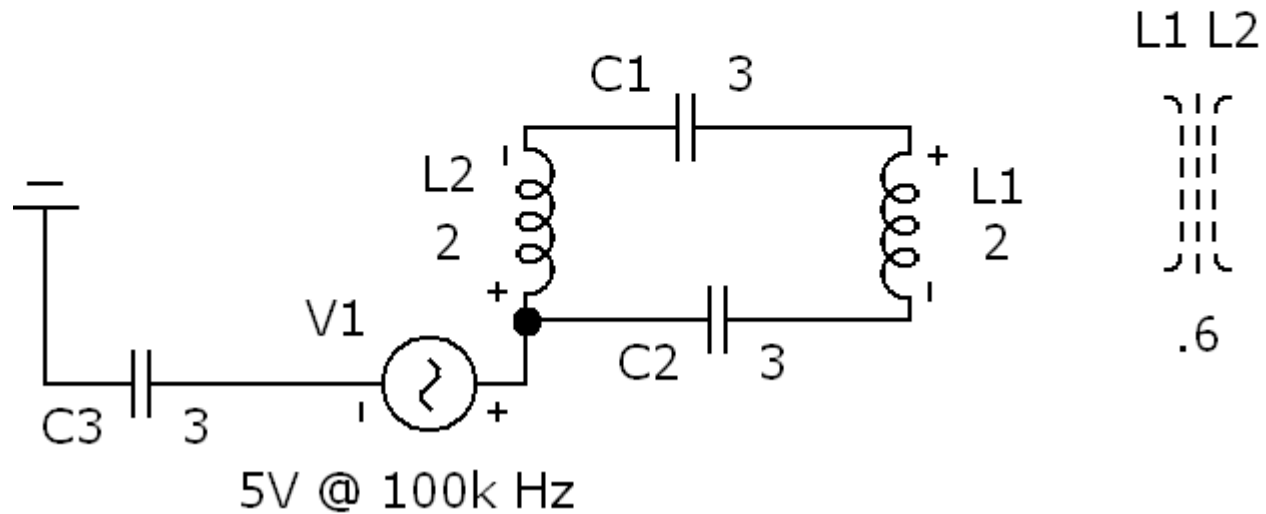

Fig. 26: Schematic of Two Capacitors, Two Coupled Inductors and One additional Capacitor between Ground and a 5V @ 100k Hz Sine Wave Generator.

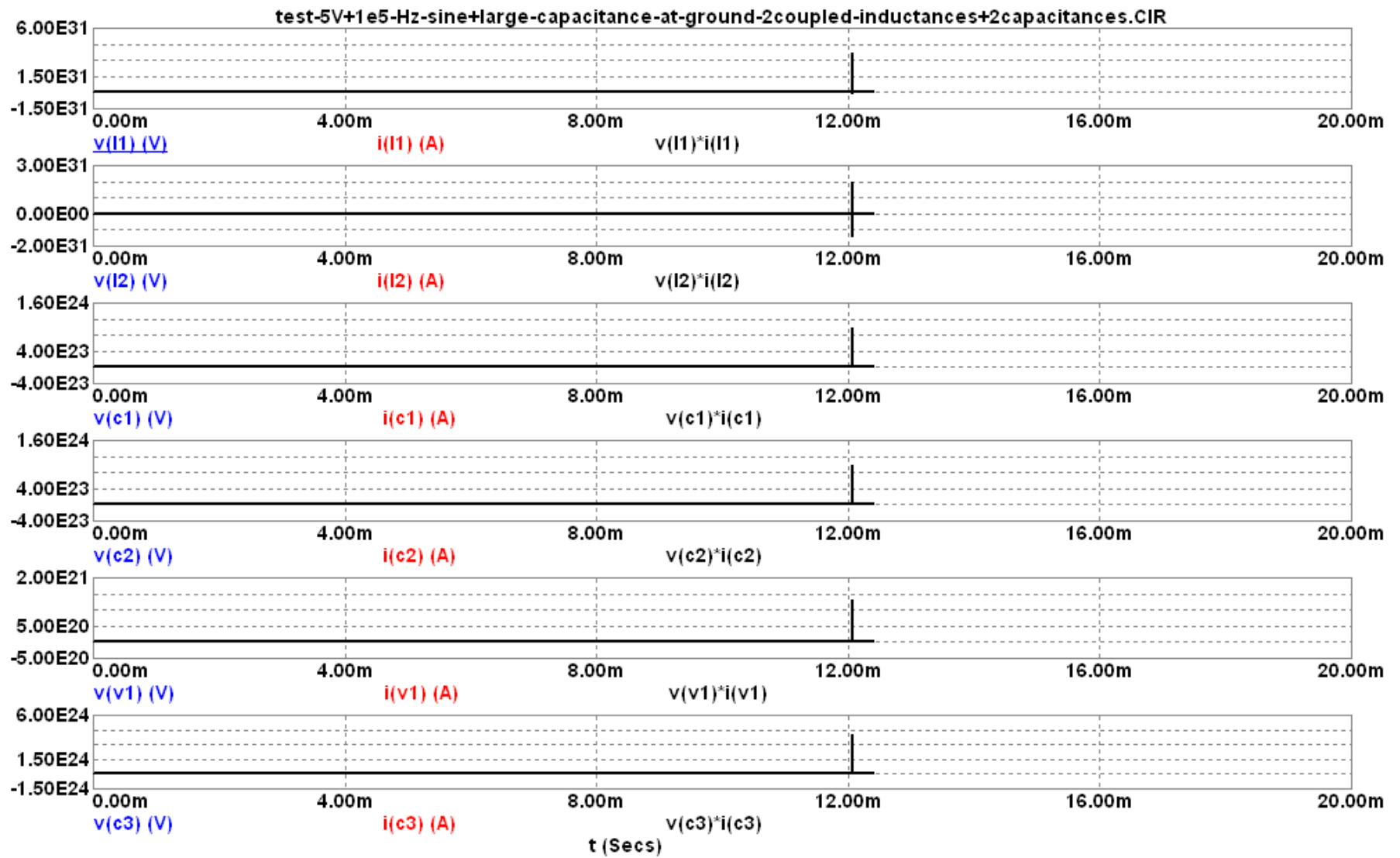

Fig. 27: Output of Two Capacitors, Two Coupled Inductors and One additional Capacitor between Ground and a 5V @ 100k Hz Sine Wave Generator.

Coupled inductors possess a triangular waveform of voltage due to their back EMF indicating that they refuse to saturate with current when fed by a sine wave generator.

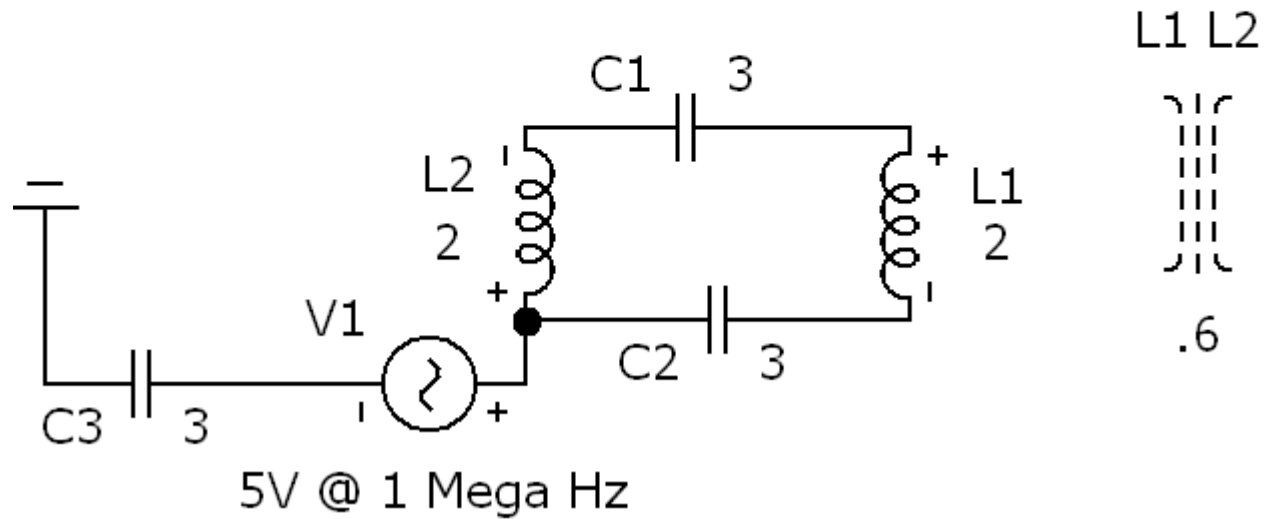

Fig. 28: Schematic of Two Capacitors, Two Coupled Inductors and One additional Capacitor between Ground and a 5V @ 1 Mega Hz Sine Wave Generator.

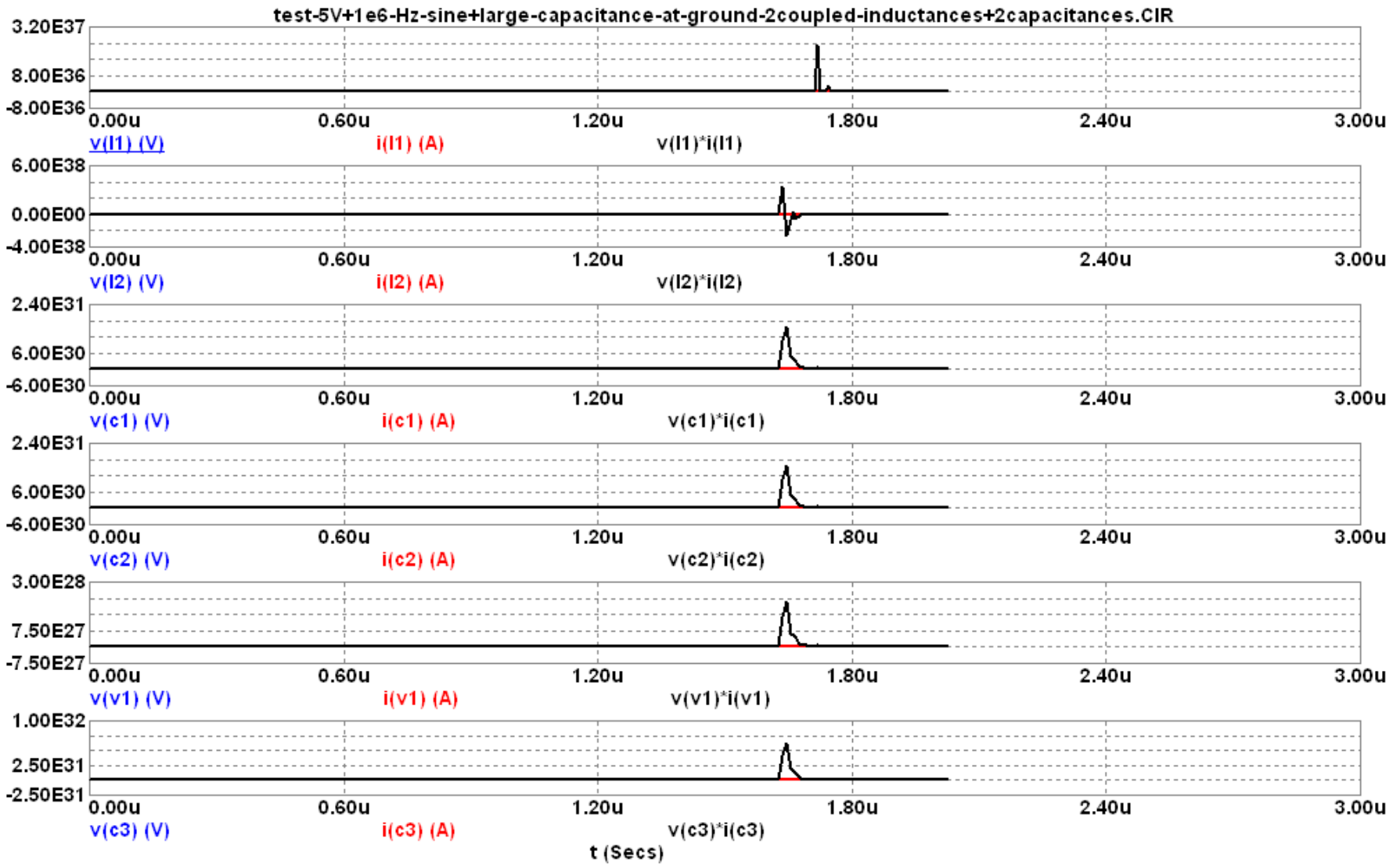

Fig. 29: Output of Two Capacitors, Two Coupled Inductors and One additional Capacitor between Ground and a 5V @ 1 Mega Hz Sine Wave Generator.

Well, now, wasn't that refreshing? ;-) But kind of short-lived... We must try for something better... Think we can make it?

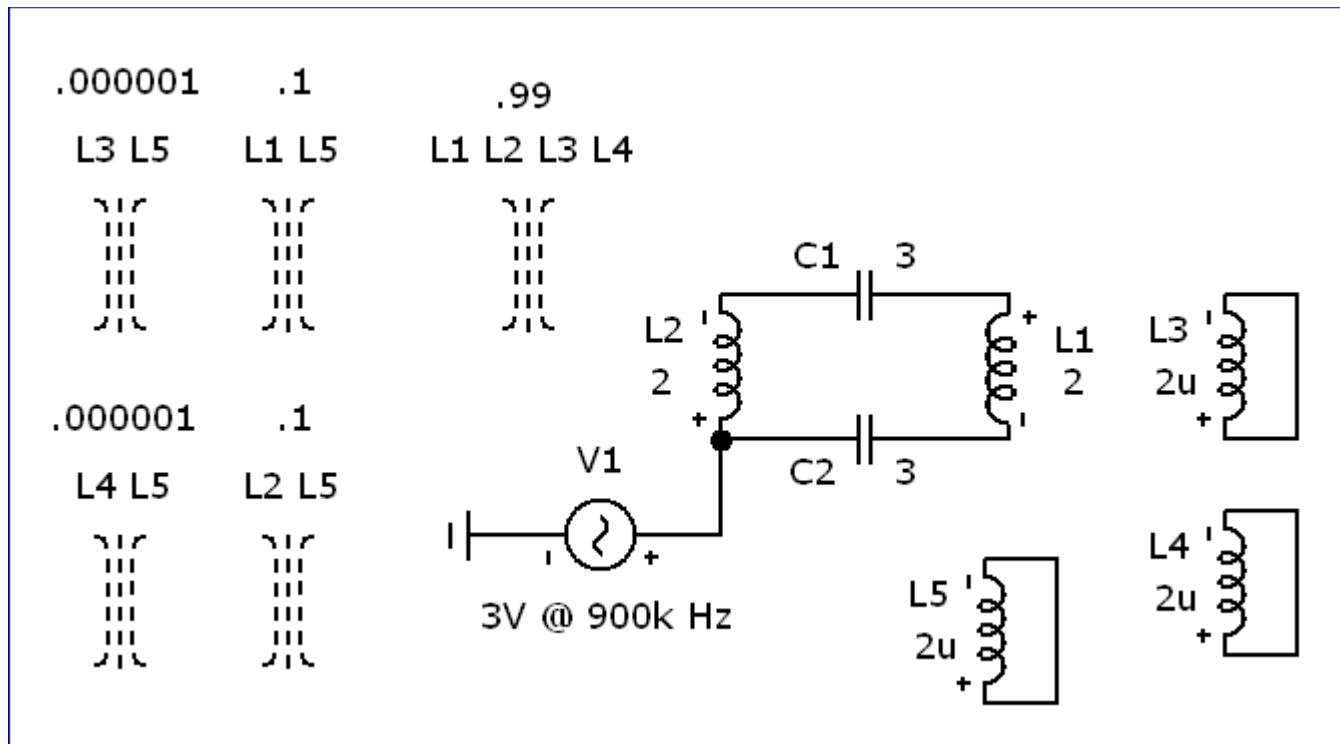

Fig. 30: Schematic of Two Capacitors, Five Coupled Inductors and One additional Capacitor between Ground and a 5V @ 900k Hz Sine Wave Generator.

Little interlude playing John Lennon's, "Imagine"...



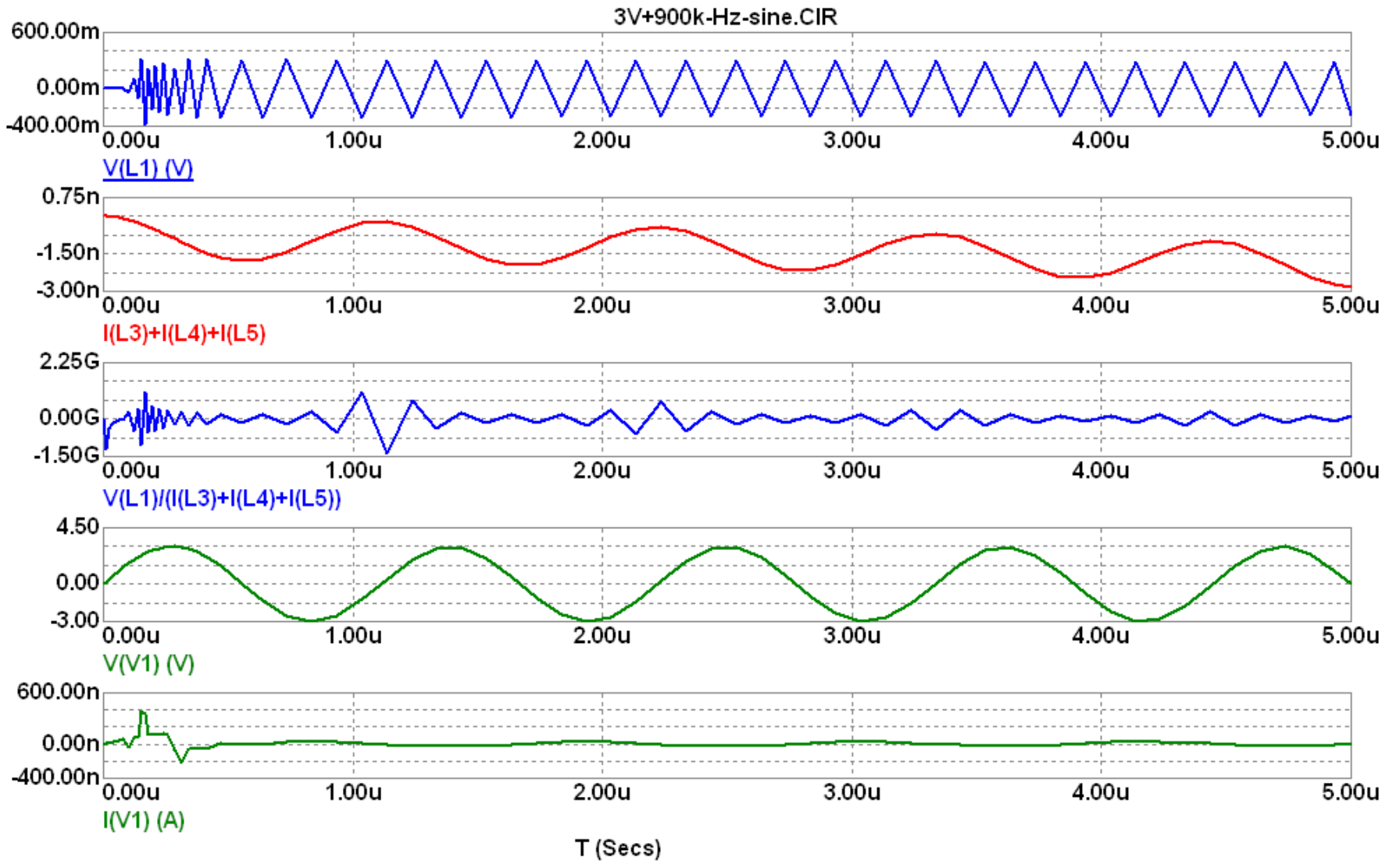

Fig. 31: Five Micro-Seconds of Output from Two Capacitors, Five Coupled Inductors and One additional Capacitor between Ground and a 5V @ 900k Hz Sine Wave Generator.

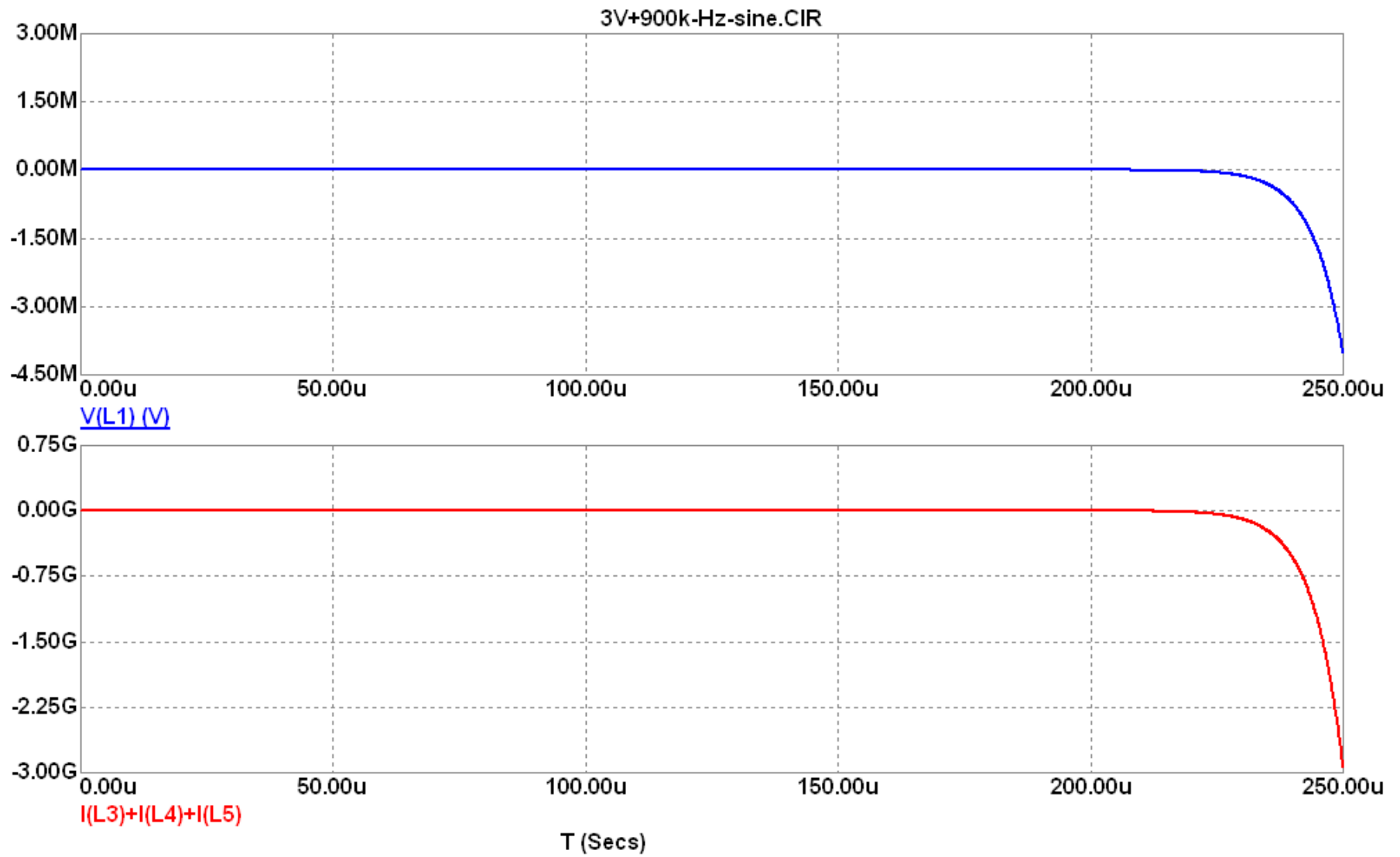

Fig. 32: Output from 250 Micro-Seconds of Run-Time from Tesla's TriMetal Generator fed by a 3V @ 20k Hz Sine Wave Generator.

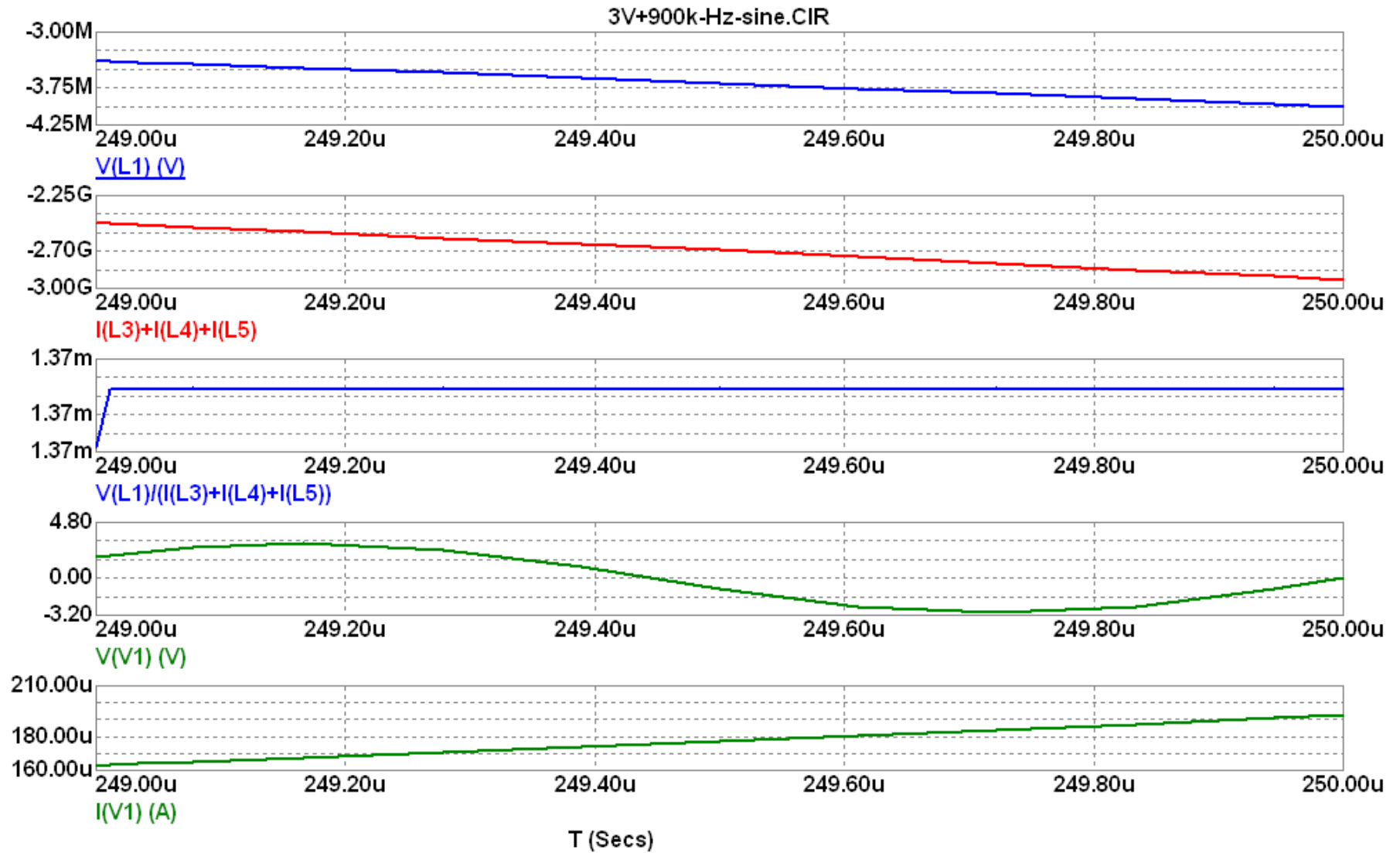

Fig. 33: Last Micro-Second of Output after 249 Micro-Seconds of Run-Time from Tesla's TriMetal Generator fed by a 3V @ 20k Hz Sine Wave Generator.

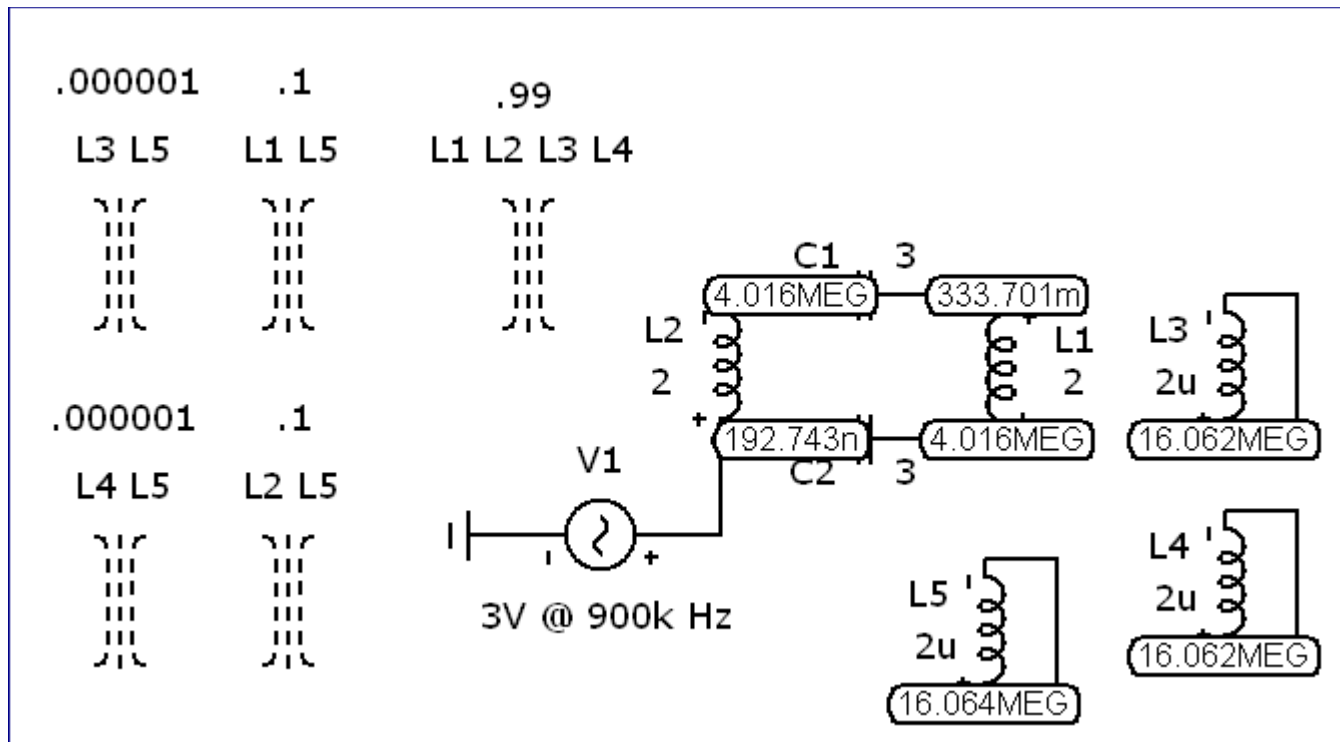

Fig. 34: Nodal Voltages after 250 Micro-Seconds of Run-Time from Tesla's TriMetal Generator fed by a 3V @ 20k Hz Sine Wave Generator.

Wow! Are you in for a treat...!

Although this may be a challenge to build, it hits the mark for my car's requirements and holds onto these outputs without blowing up...

<http://vinyasi.info/graham/max%20acceleration%20for%20a%202002%20RAV4EV/>

PANCAKE COIL LAYERING FOR VC1, VC2, CC1, CC2 & Transfer COILS...

IRON  
COPPER  
ALUMINUM  
COPPER  
IRON

ALL WOUND IN THE SAME DIRECTION

exactly 10% C.Coef.

Transfer-VC1  
Transfer VC1

exactly 10% C.Coef.

Transfer VC2  
Transfer VC2

30 AWG = VC1, VC2  
24 AWG = LOAD  
10 AWG = CC1, CC2 & TRANSFER COIL

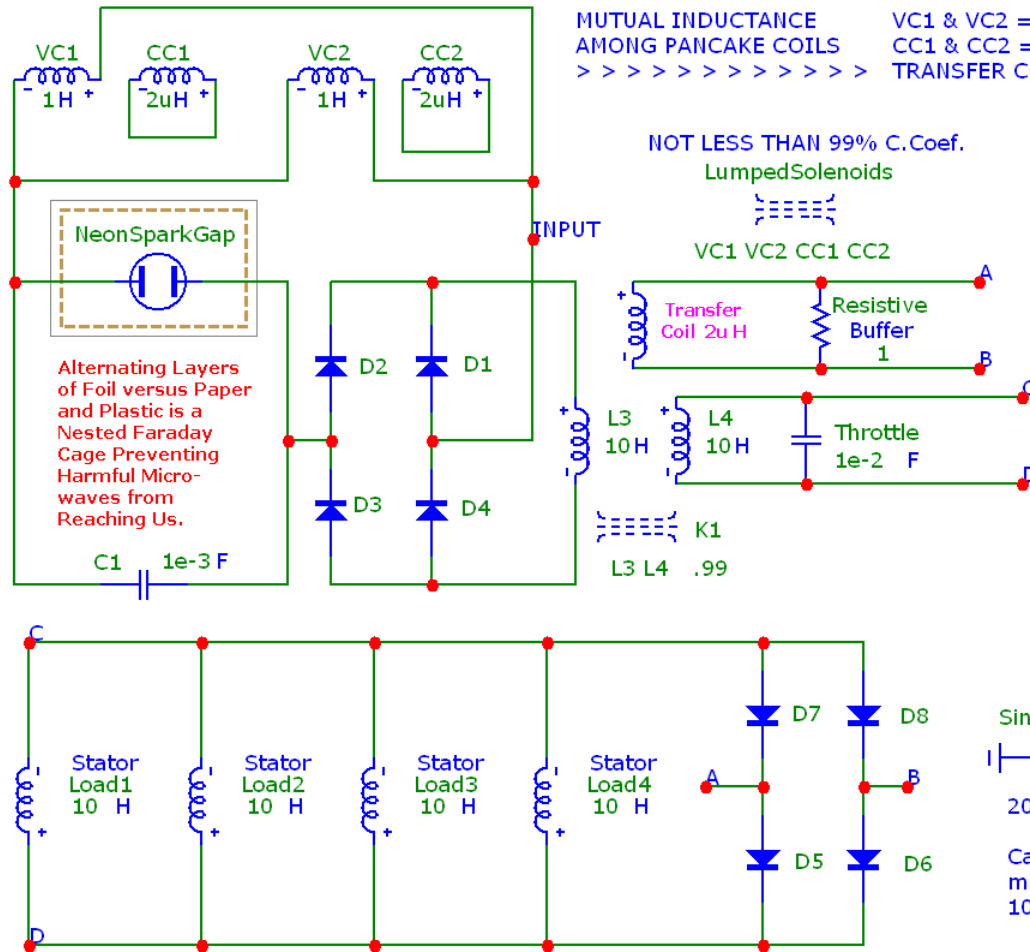

MUTUAL INDUCTANCE AMONG PANCAKE COILS  
> > > > > > > >

VC1 & VC2 = 99%  
CC1 & CC2 =  $\text{SQRT}\{100\% - (VC1 \text{ or } VC2)\}$   
TRANSFER COIL =  $\{100\% - (VC1 \text{ or } VC2)\}^3$

NOT LESS THAN 99% C.Coef.  
Lumped Solenoids

**POWER SUPPLY PLUS LOAD**

IRON COILS VC1 & VC2

ALUMINUM COIL TRANSFER COIL

COPPER COILS CC1 & CC2

<< exactly 0.000001% C.Coef. >>  
Transfer-CC1  
Transfer CC1  
Transfer-CC2  
Transfer CC2

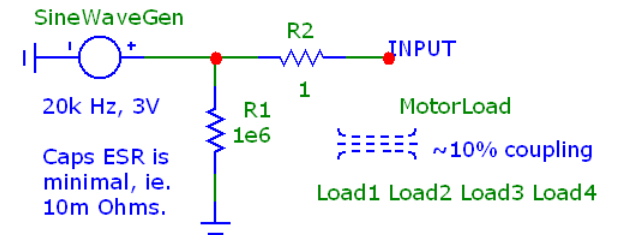

Fig. 35: Schematic of Tesla's TriMetal Generator fed by a 3V @ 20k Hz Sine Wave Generator.

**Transient Analysis Limits**

Run Add Delete Expand... Stepping... PSS... Properties... Help...

Maximum Run Time: 10  
 Output Start Time (tstart): 0  
 Maximum Time Step: 0  
 Number of Points: 51  
 Temperature: Linear 27  
 Retrace Runs: 1

Run Options: Normal  
 State Variables: Zero

Operating Point  Accumulate Plots  
 Operating Point Only  Fixed Time Step  
 Auto Scale Ranges  Periodic Steady State

<input type="checkbox"/> Ignore Expression Errors	P	X Expression	Y Expression	X Range	Y Range
<input checked="" type="checkbox"/>	1	T	V(Load1)	AUTOALWAYS	AUTOALWAYS
<input checked="" type="checkbox"/>	2	T	I(Load1)+I(Load2)+I(Load3)+I(Load4)	AUTOALWAYS	AUTOALWAYS
<input checked="" type="checkbox"/>	3	T	(V(Load1))*(I(Load1)+I(Load2)+I(Load3)+I(Load4))	AUTOALWAYS	AUTOALWAYS
<input checked="" type="checkbox"/>	5	T	((V(Load1))*(I(Load1)+I(Load2)+I(Load3)+I(Load4)))/(RM5(V(SineWaveGen))*RM5(I(SineWaveGen)))	AUTOALWAYS	AUTOALWAYS
<input checked="" type="checkbox"/>	4	T	V(SineWaveGen)*I(SineWaveGen)	AUTOALWAYS	AUTOALWAYS
<input checked="" type="checkbox"/>	4	T	I(SineWaveGen)	AUTOALWAYS	AUTOALWAYS
<input checked="" type="checkbox"/>	5	T	V(VC1)	AUTOALWAYS	AUTOALWAYS
<input checked="" type="checkbox"/>	6	T	I(VC1)	AUTOALWAYS	AUTOALWAYS
<input checked="" type="checkbox"/>	7	T	V(CC1)	AUTOALWAYS	AUTOALWAYS
<input checked="" type="checkbox"/>	8	T	I(CC1)	AUTOALWAYS	AUTOALWAYS
<input checked="" type="checkbox"/>	9	T	V(TRANSFER)	AUTOALWAYS	AUTOALWAYS
<input checked="" type="checkbox"/>	10	T	I(TRANSFER)	AUTOALWAYS	AUTOALWAYS
<input checked="" type="checkbox"/>	11	T	V(L3)	AUTOALWAYS	AUTOALWAYS
<input checked="" type="checkbox"/>	12	T	I(L3)	AUTOALWAYS	AUTOALWAYS
<input checked="" type="checkbox"/>	13	T	V(L4)	AUTOALWAYS	AUTOALWAYS
<input checked="" type="checkbox"/>	14	T	I(L4)	AUTOALWAYS	AUTOALWAYS
<input checked="" type="checkbox"/>	15	T	V(C1)	AUTOALWAYS	AUTOALWAYS
<input checked="" type="checkbox"/>	16	T	I(C1)	AUTOALWAYS	AUTOALWAYS

Fig. 36: Output Parameters of Tesla's TriMetal Generator fed by a 3V @ 20k Hz Sine Wave Generator.

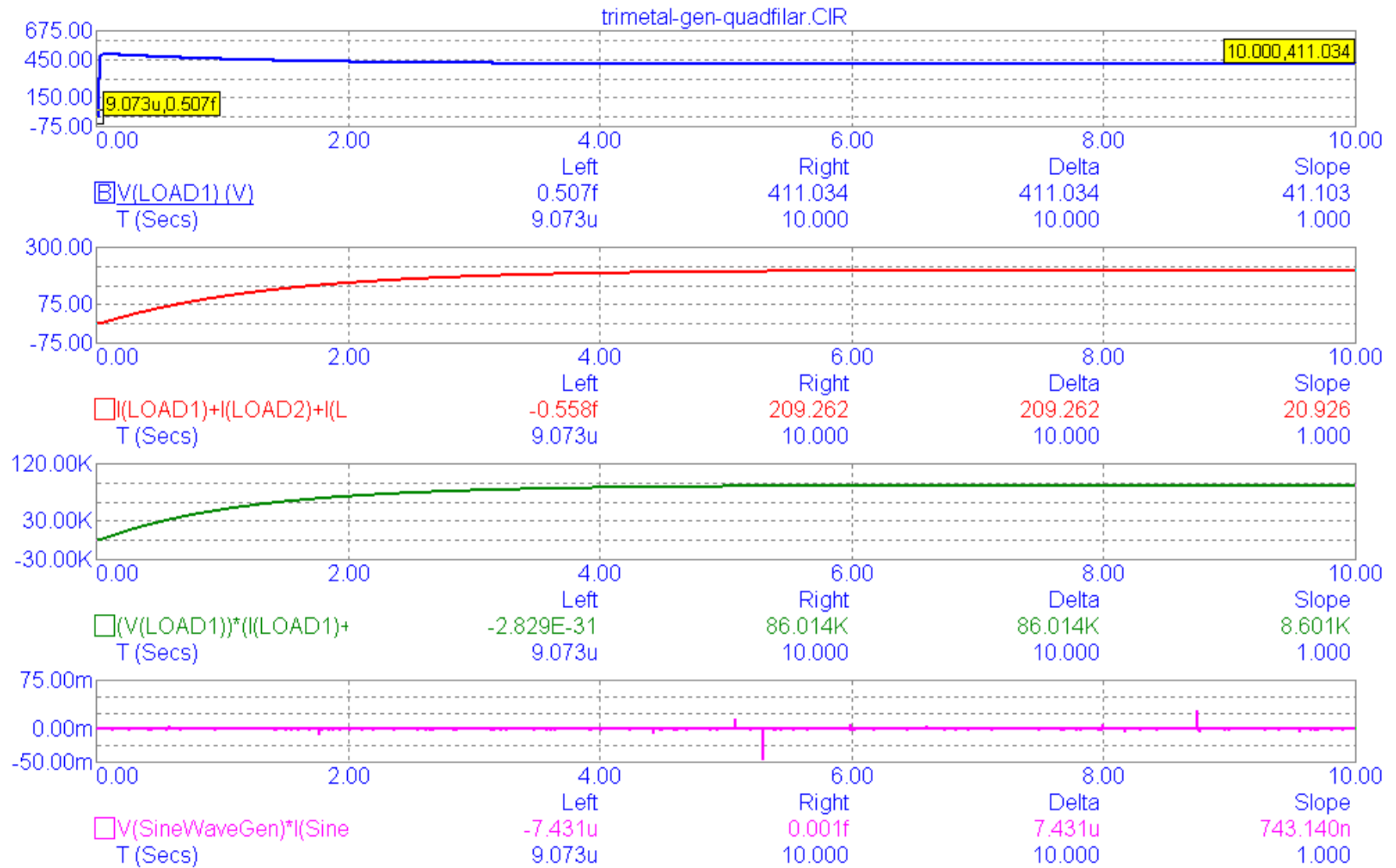

Fig. 37: Two Seconds of Output from Tesla's TriMetal Generator fed by a 3V @ 20k Hz Sine Wave Generator.

PANCAKE COIL LAYERING FOR VC1, VC2, CC1, CC2 & Transfer COILS...

IRON  
COPPER  
ALUMINUM  
COPPER  
IRON

ALL WOUND IN THE SAME DIRECTION

exactly 10% C.Coef.

Transfer-VC1  
Transfer VC1

exactly 10% C.Coef.

Transfer-VC2  
Transfer VC2

30 AWG = VC1, VC2  
24 AWG = LOAD  
10 AWG = CC1, CC2 & TRANSFER COIL

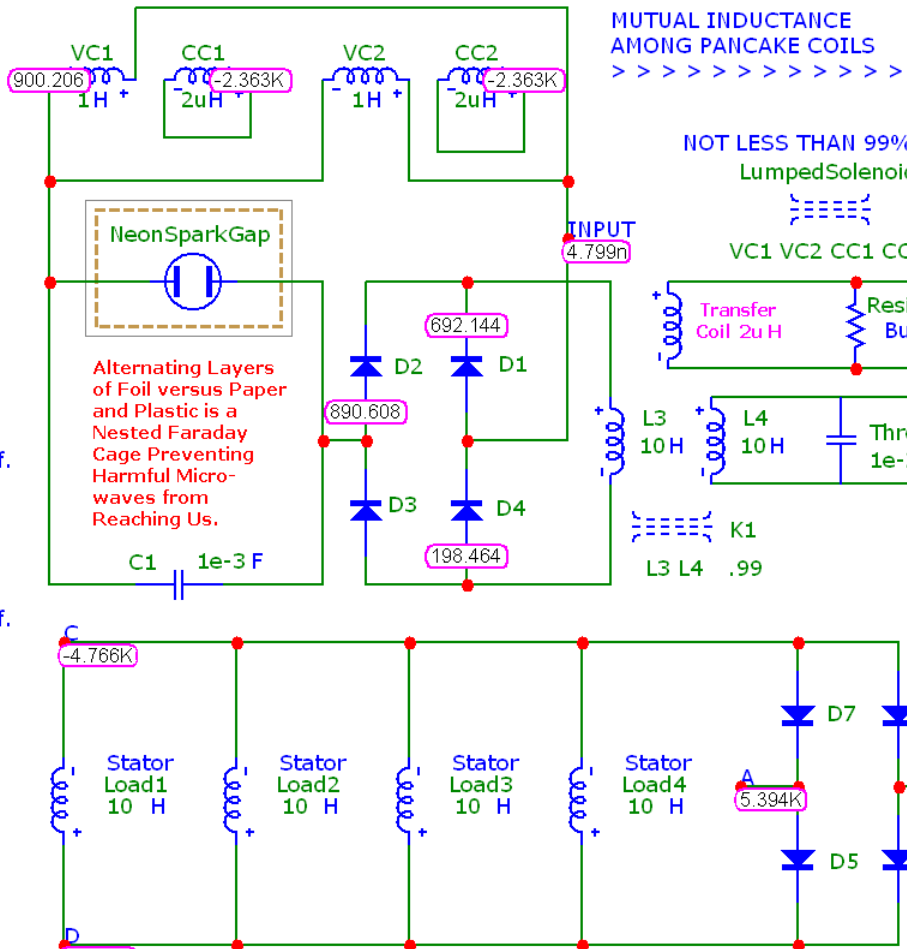

MUTUAL INDUCTANCE AMONG PANCAKE COILS  
> > > > > > > > >

VC1 & VC2 = 99%  
CC1 & CC2 =  $\text{SQRT}\{100\% - (VC1 \text{ or } VC2)\}$   
TRANSFER COIL =  $\{100\% - (VC1 \text{ or } VC2)\}^3$

NOT LESS THAN 99% C.Coef.  
Lumped Solenoids

**POWER SUPPLY PLUS LOAD**

IRON COILS VC1 & VC2

ALUMINUM COIL TRANSFER COIL

COPPER COILS CC1 & CC2

<< exactly 0.000001% C.Coef. >>  
Transfer-CC1  
Transfer CC1  
Transfer-CC2  
Transfer CC2

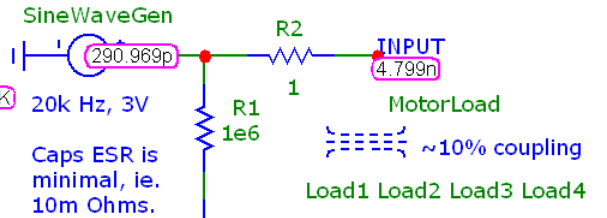

Fig. 38: Nodal Voltages after Two Seconds of Run-Time from Tesla's TriMetal Generator fed by a 3V @ 20k Hz Sine Wave Generator.



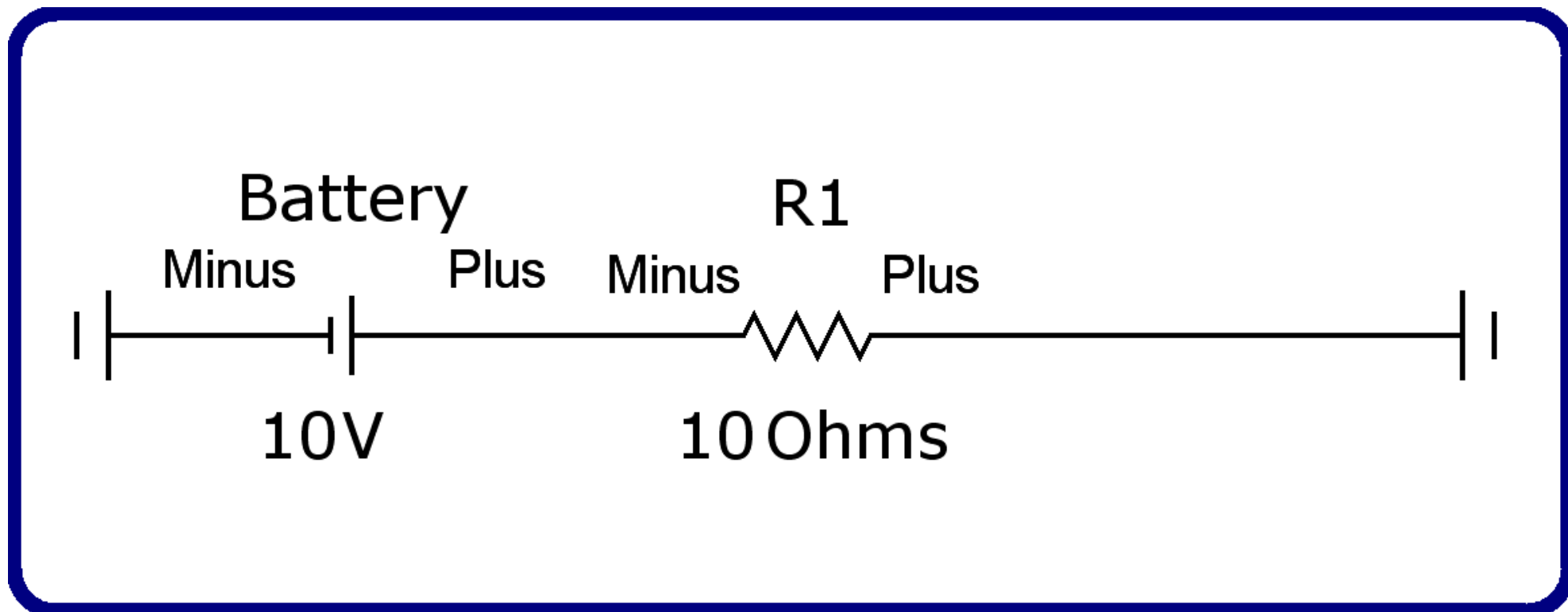
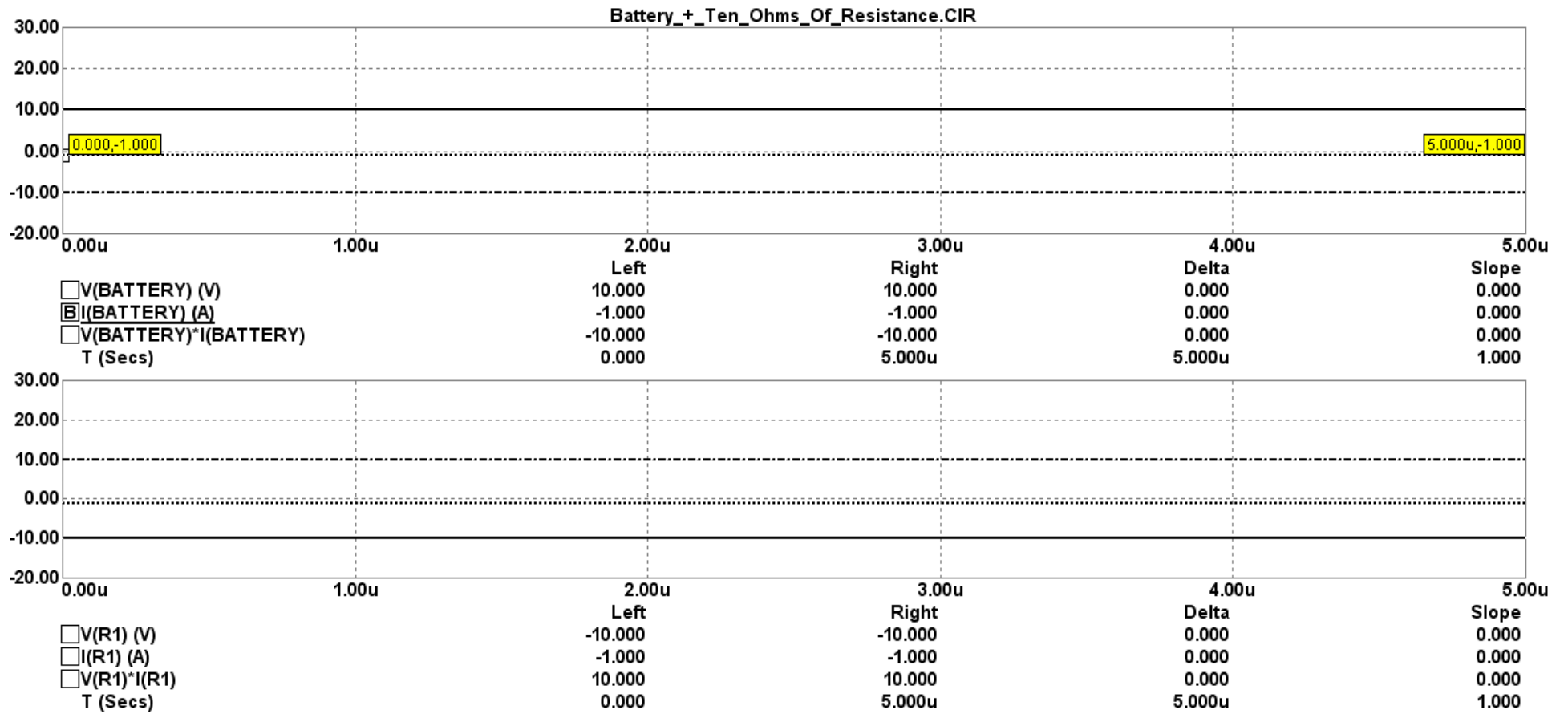

FIG. 1



**FIG. 2**

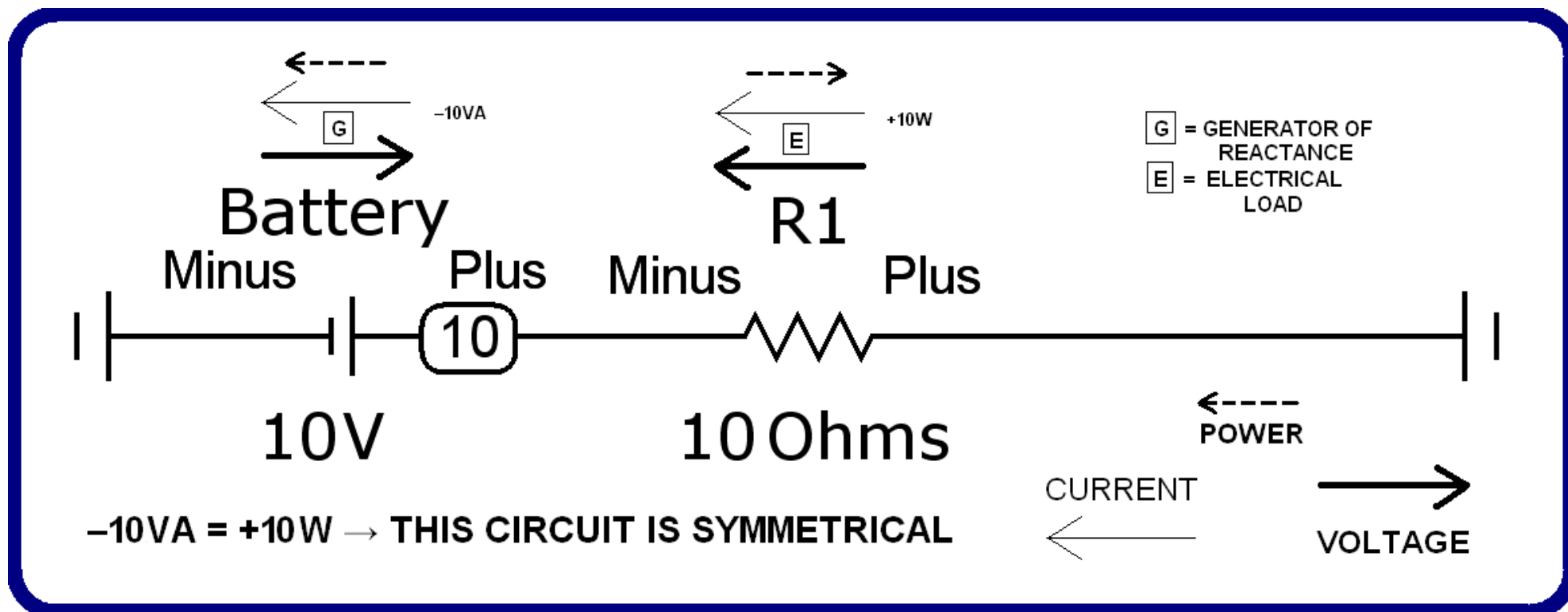

FIG. 3

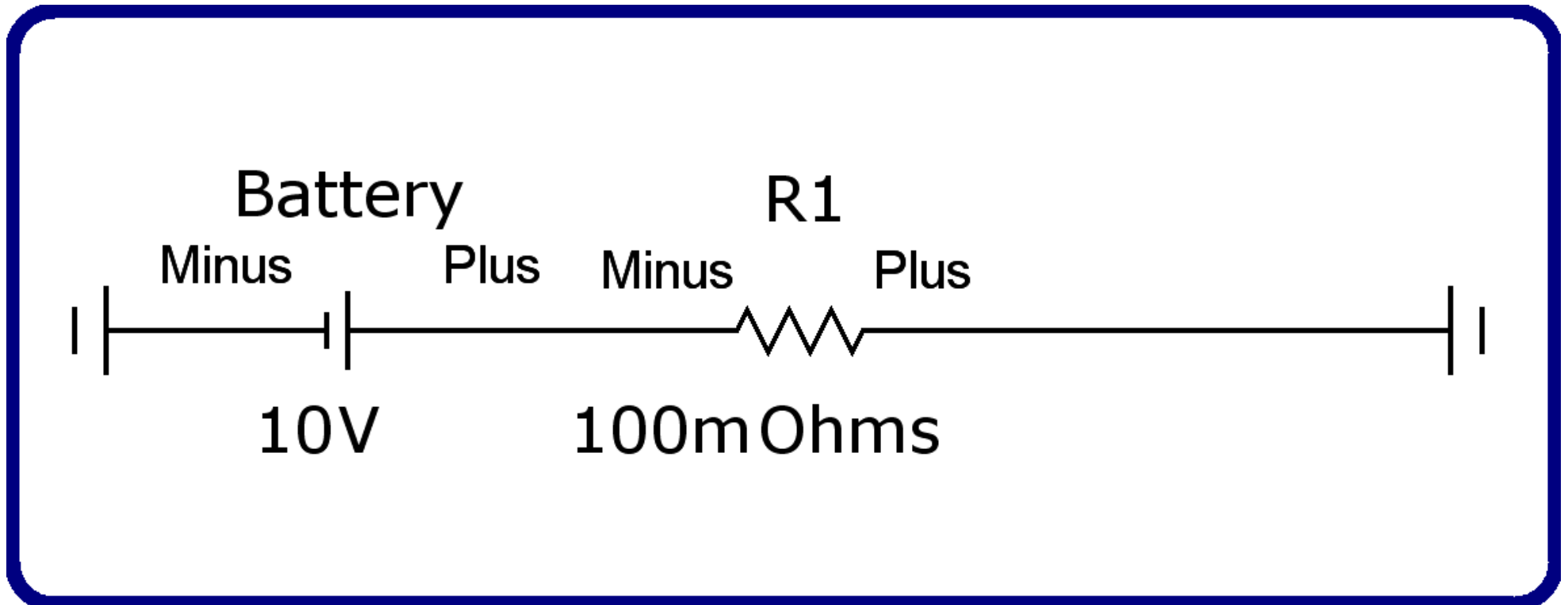
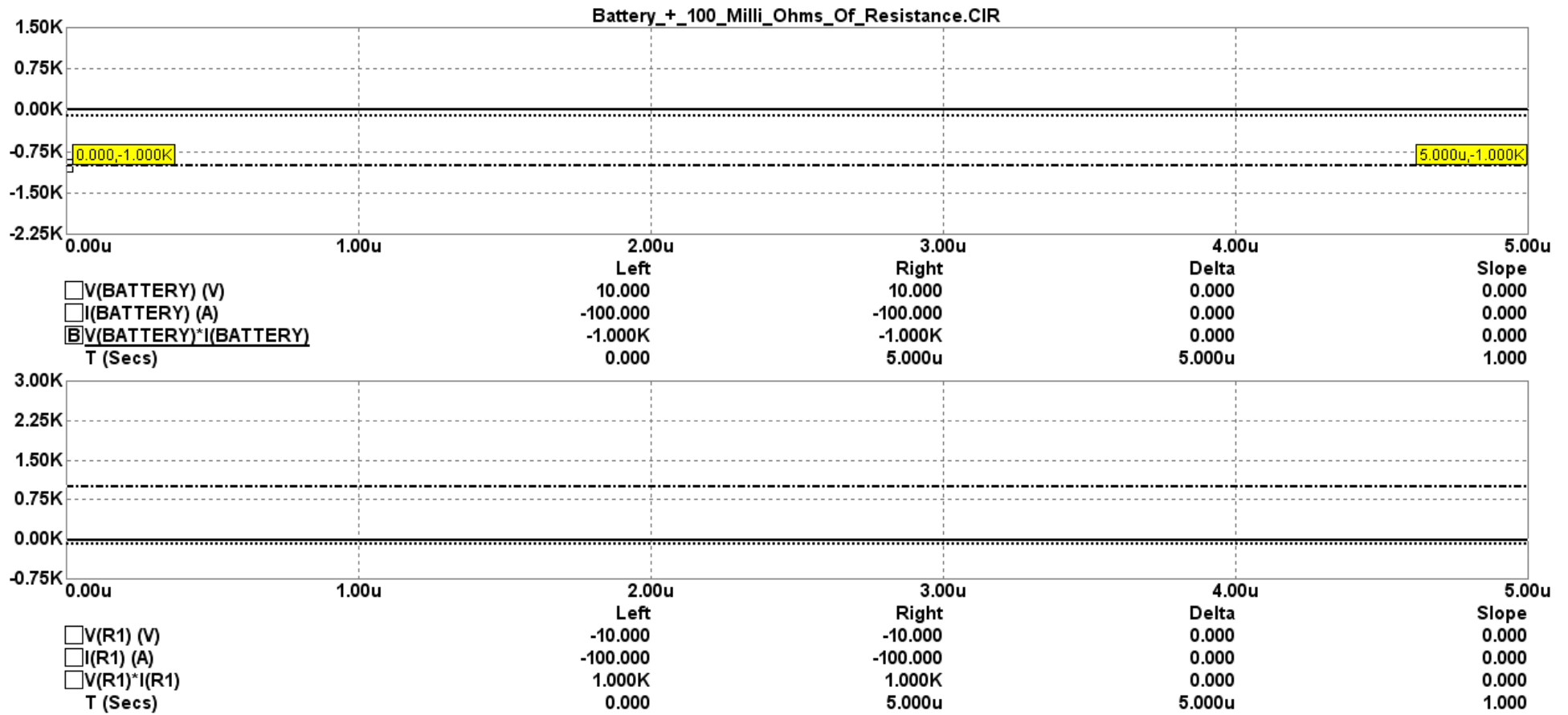

FIG. 4



**FIG. 5**

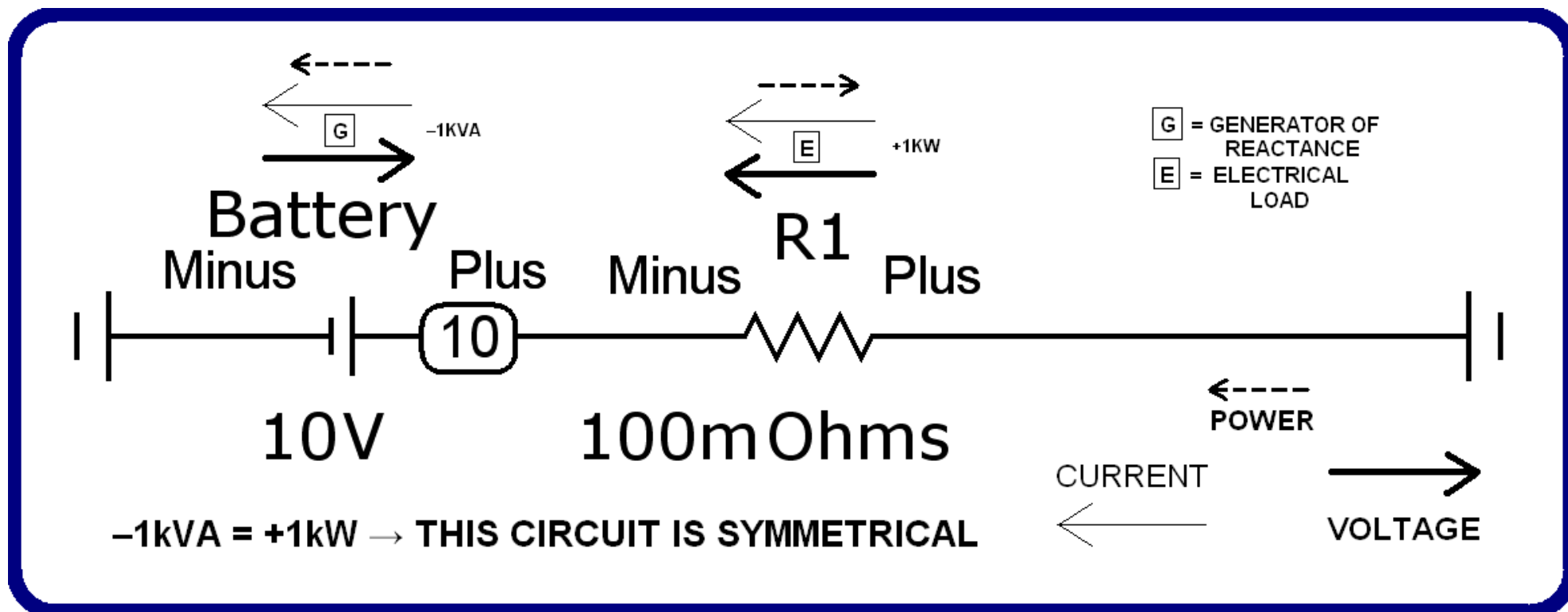

FIG. 6

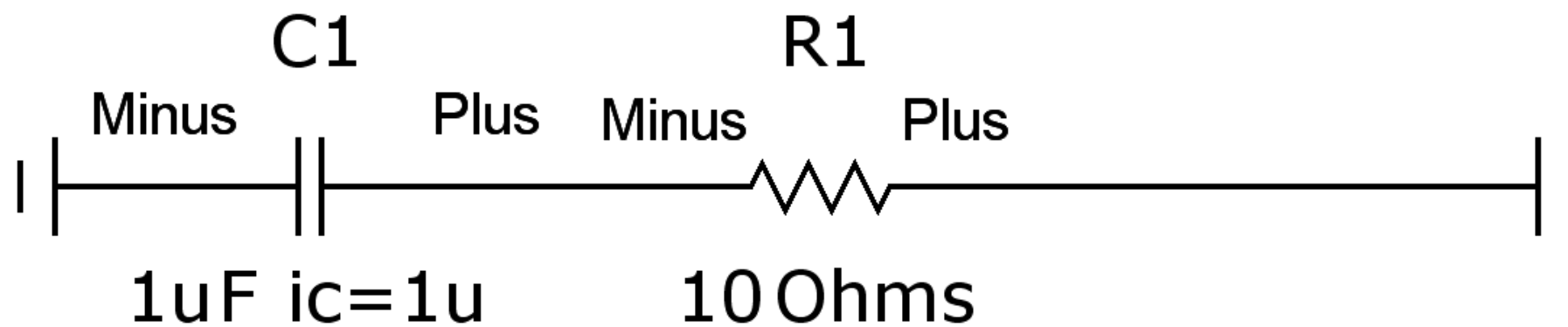
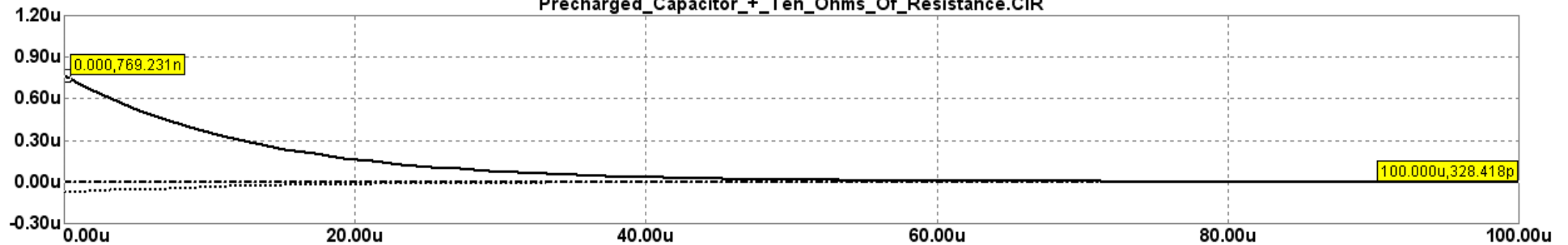
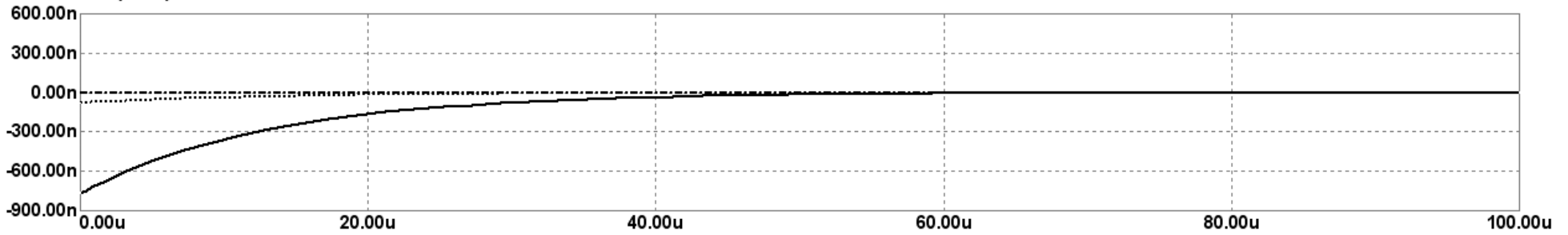

FIG. 7

Precharged\_Capacitor+\_Ten\_Ohms\_Of\_Resistance.CIR



	Left	Right	Delta	Slope
V(C1) (V)	769.231n	328.418p	-768.902n	-7.689m
I(C1) (A)	-76.923n	-32.842p	76.890n	768.902u
V(C1)*I(C1)	-59.172f	-1.079E-20	59.172f	591.716p
T (Secs)	0.000	100.000u	100.000u	1.000



	Left	Right	Delta	Slope
V(R1) (V)	-769.231n	-328.418p	768.902n	7.689m
I(R1) (A)	-76.923n	-32.842p	76.890n	768.902u
V(R1)*I(R1)	59.172f	1.079E-20	-59.172f	-591.716p
T (Secs)	0.000	100.000u	100.000u	1.000

FIG. 8



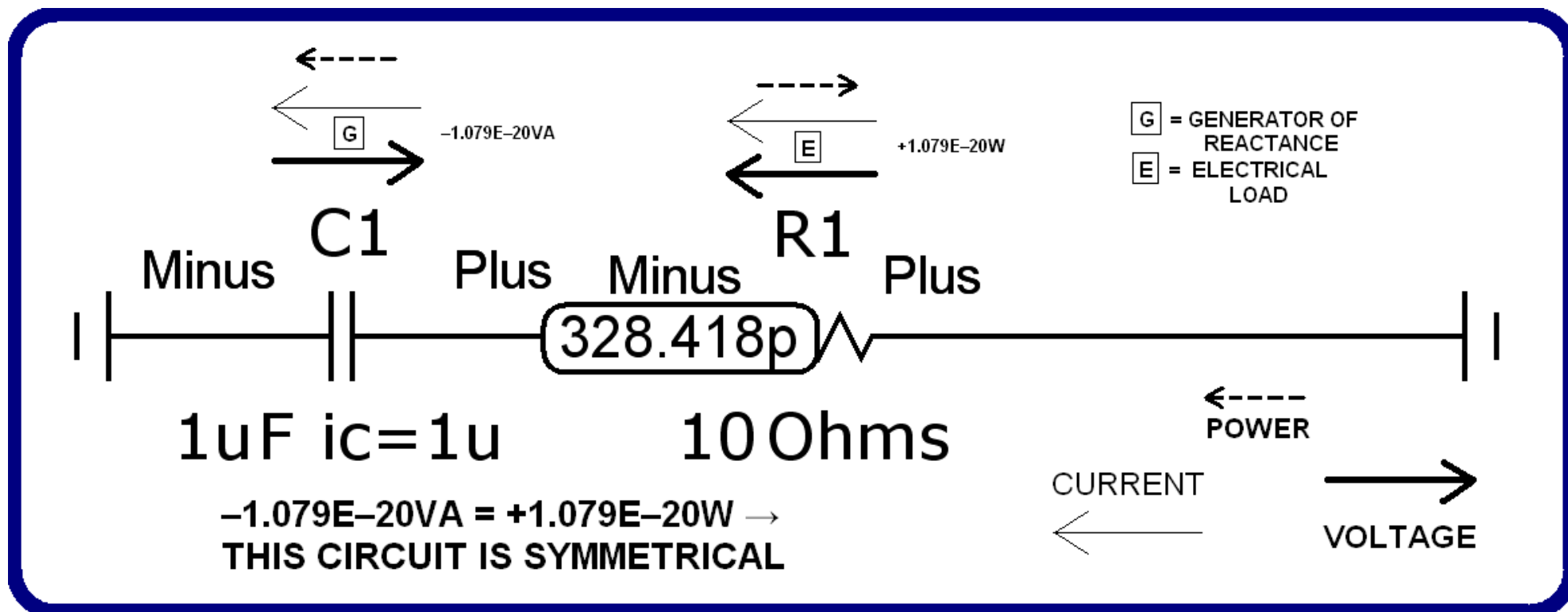

FIG. 9

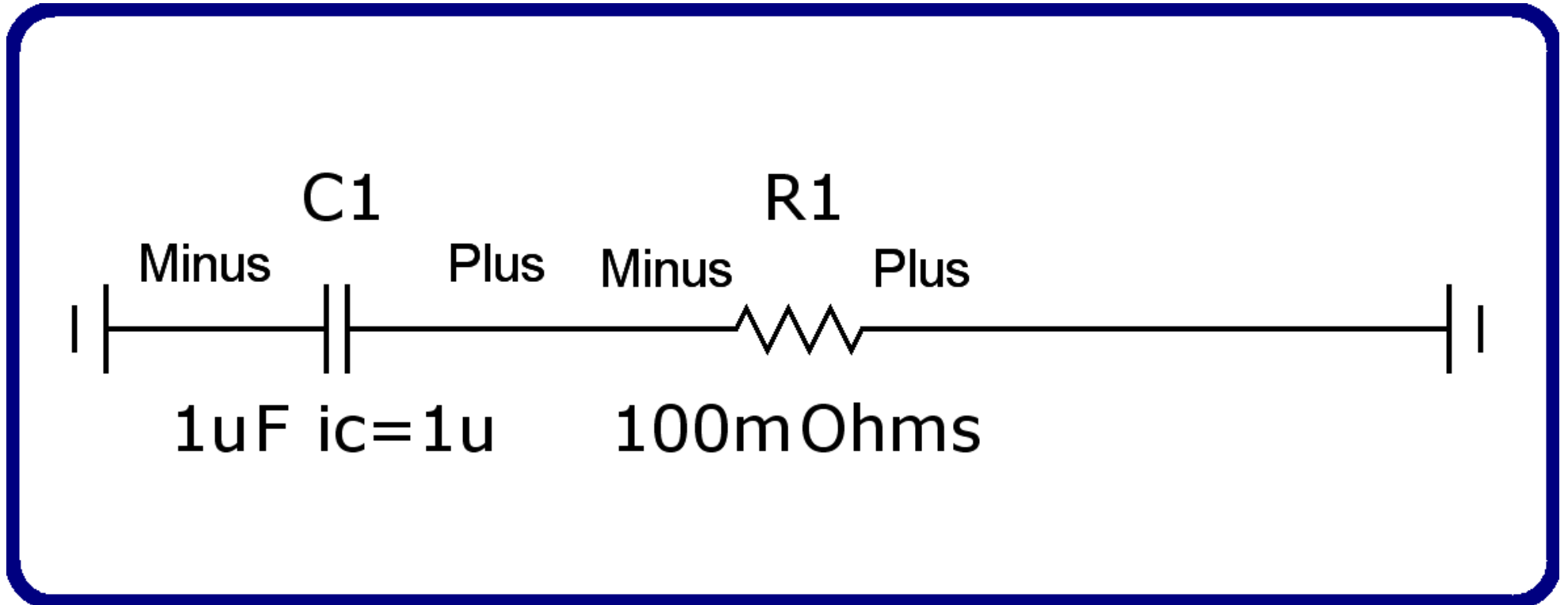

FIG. 10

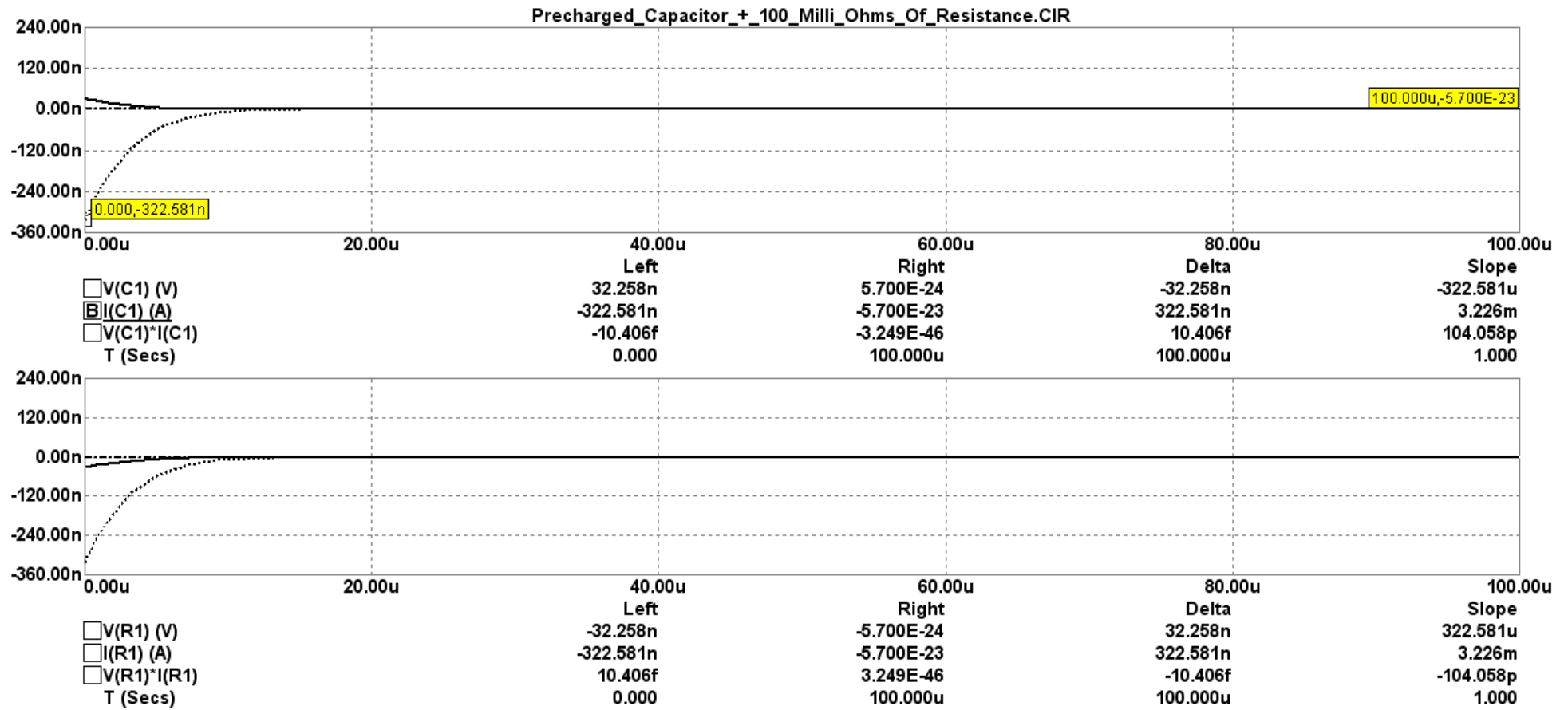

FIG. 11

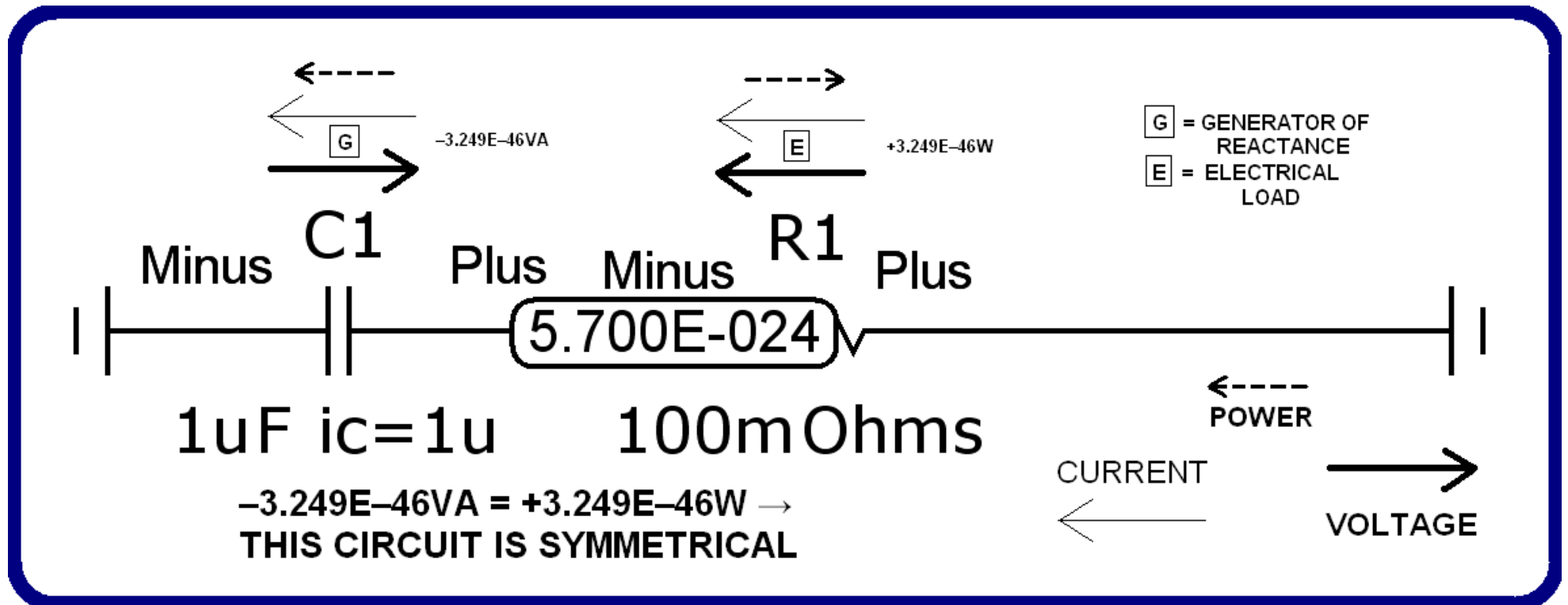

FIG. 12

## NEON BULB, SPARK GAP MACRO

.PARAMETERS(VTHRES=90, VARC=10, ISUS=500M,RNEG=-1,LPL=130N,RPL=2K,CPAR=1P,CARC=3P)

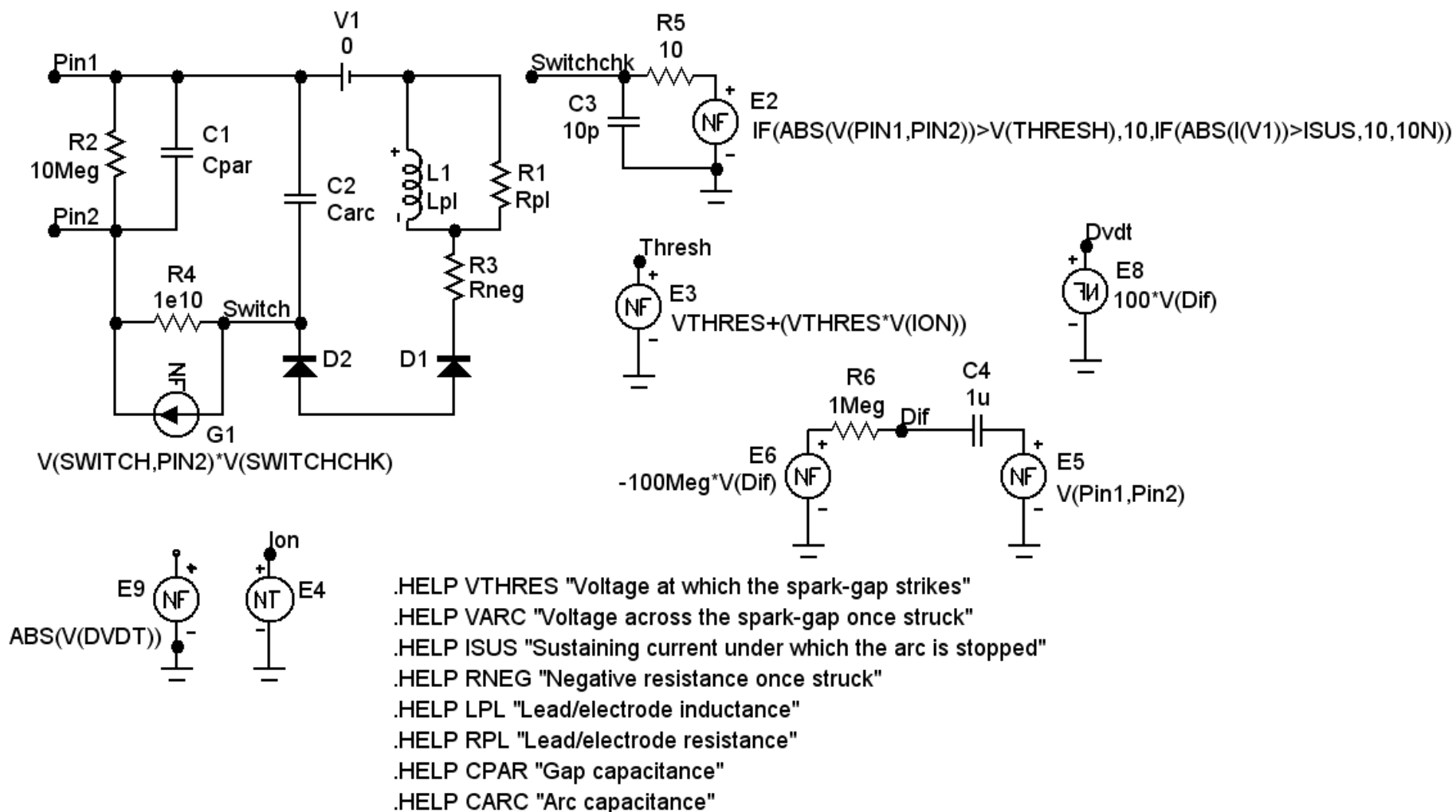

FIG. 13

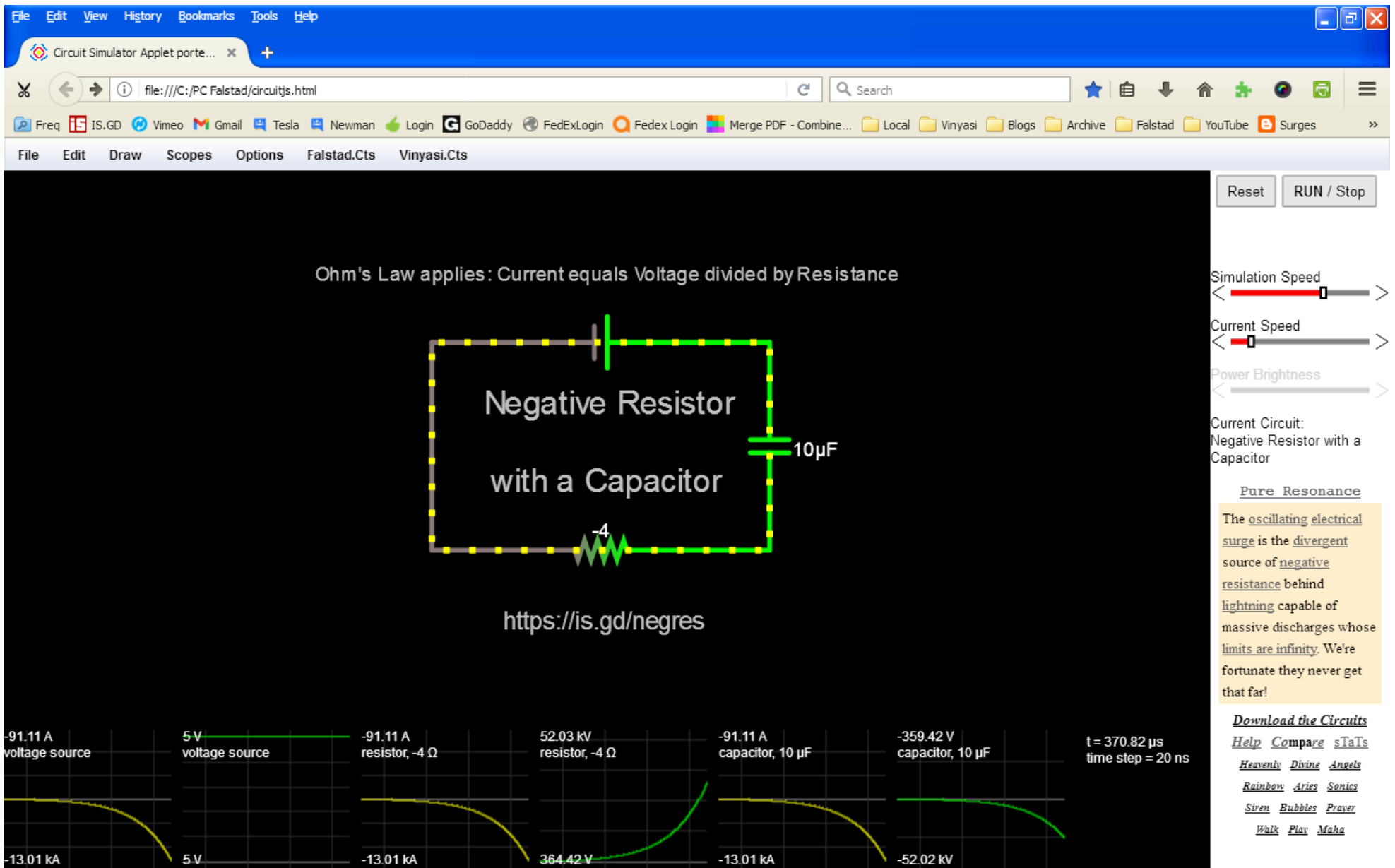

FIG. 14

## NEON BULB, SPARK GAP MACRO

.PARAMETERS(VTHRES=90, VARC=10, ISUS=500M,RNEG=-1,LPL=130N,RPL=2K,CPAR=1P,CARC=3P)

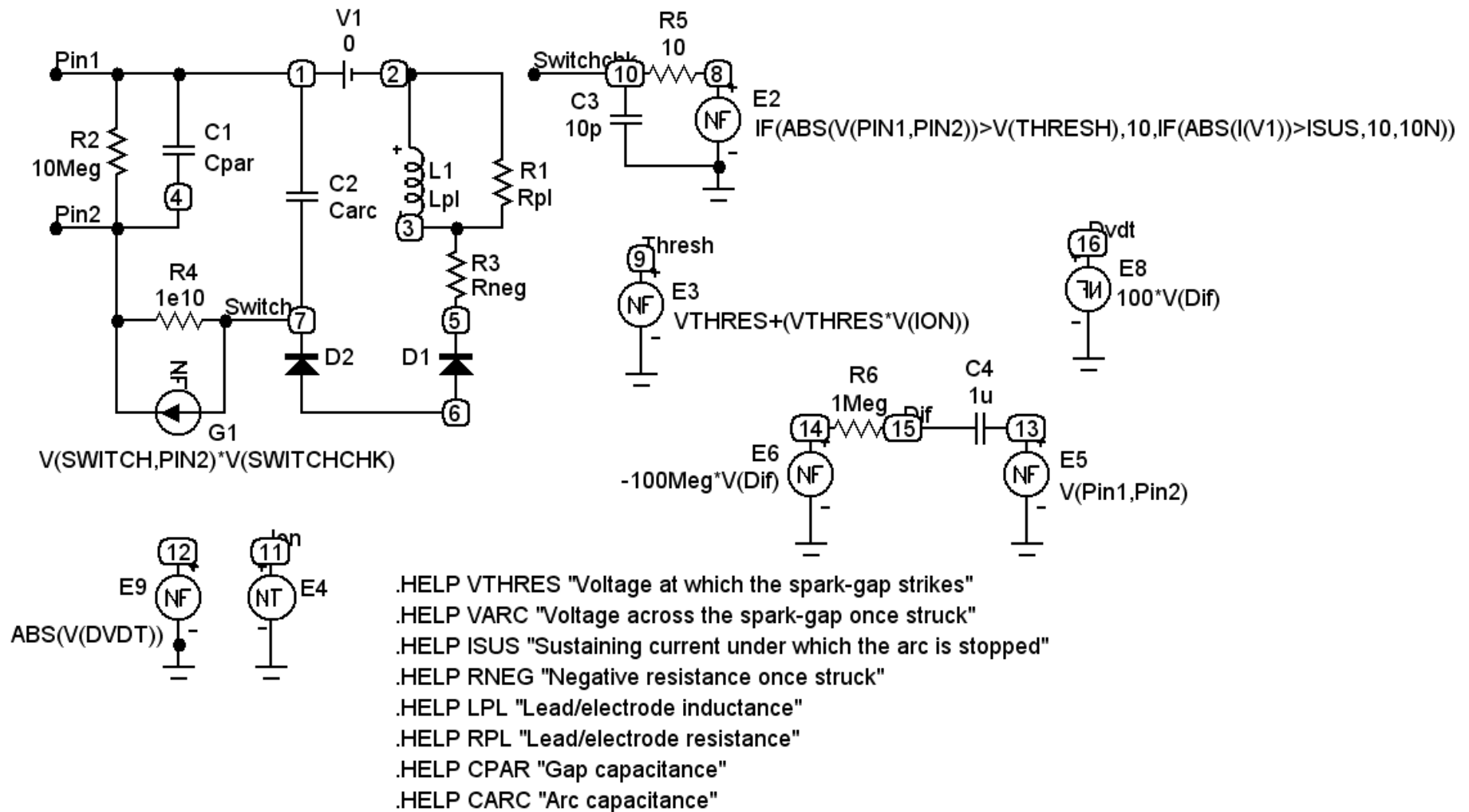
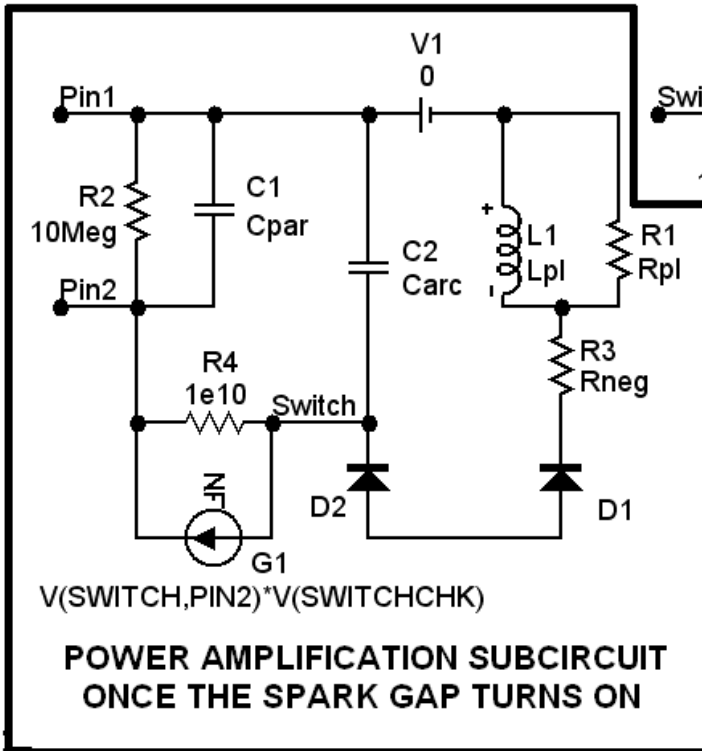

FIG. 15

# SPARKGAP MACRO

.PARAMETERS(GRES=1,VTHRES=90,VARC=10,ISUS=500M,RNEG=-1,LPL=130N,RPL=2K,CPAR=1P,CARC=3P)



**EVERYTHING ELSE OUTSIDE  
OF THIS SUBCIRCUIT, ABOVE,  
MERELY DETERMINES WHEN  
TO TURN ON THIS SPARK GAP  
BEYOND ITS THRESHOLD OF  
RESISTANCE.**

- .HELP GRES "Resistance of ground connection"
- .HELP VTHRES "Voltage at which the spark-gap strikes"
- .HELP VARC "Voltage across the spark-gap once struck"
- .HELP ISUS "Sustaining current under which the arc is stopped"
- .HELP RNEG "Negative resistance once struck"
- .HELP LPL "Lead/electrode inductance"
- .HELP RPL "Lead/electrode resistance"
- .HELP CPAR "Gap capacitance"
- .HELP CARC "Arc capacitance"

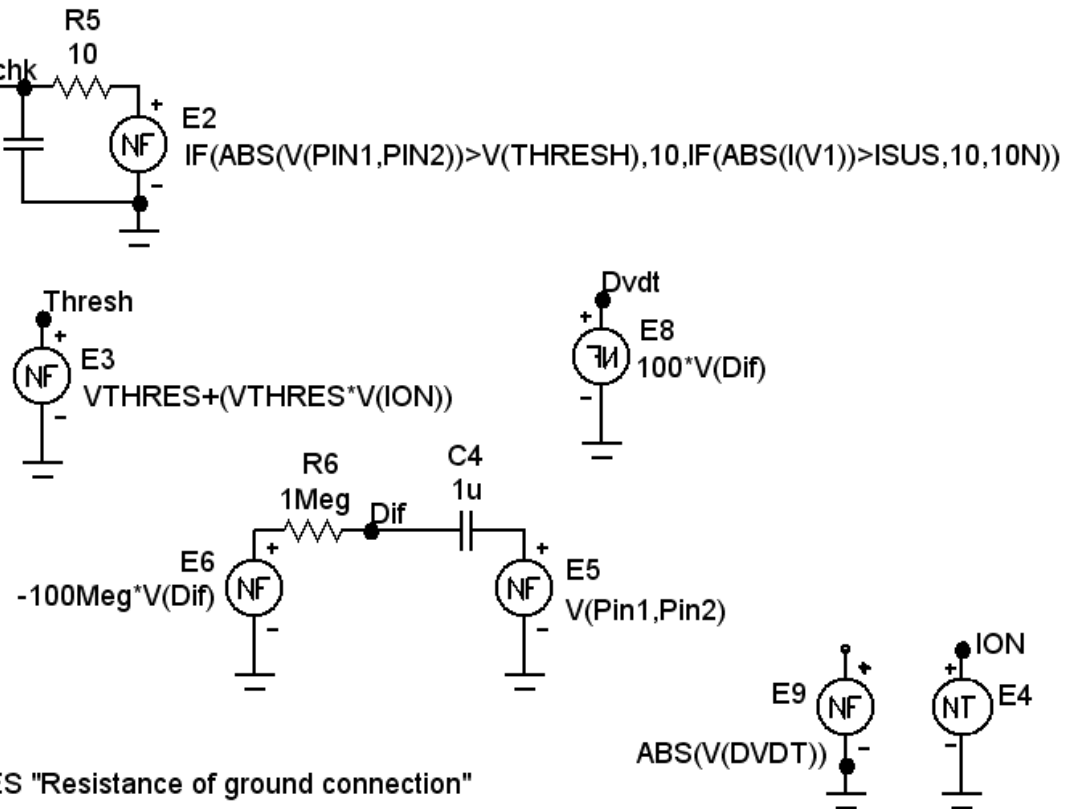
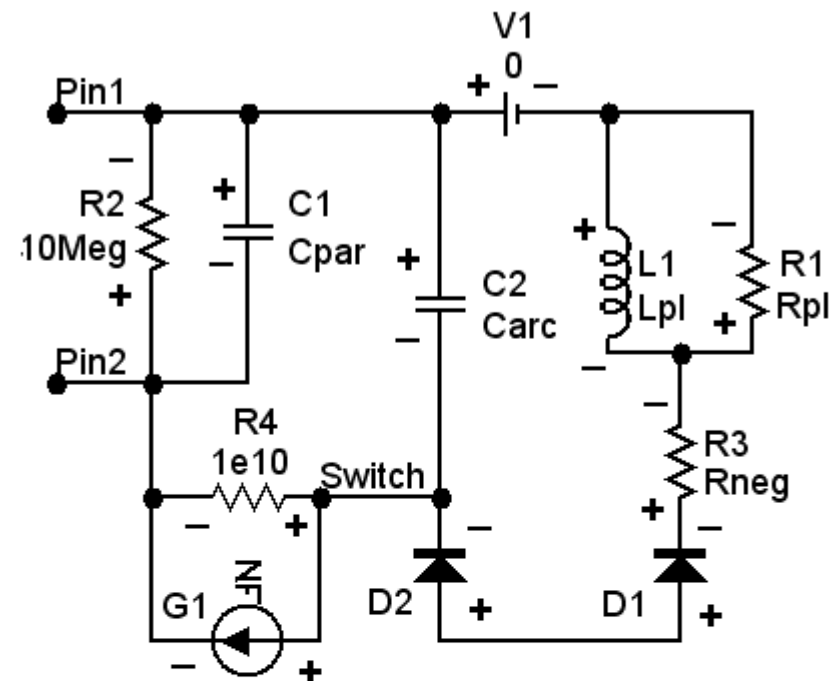

FIG. 16





$$V(\text{SWITCH}, \text{PIN2}) * V(\text{SWITCHCHK})$$

**Each component is labeled with either a positive or negative polarity to reference the polarity of its output. So, a negative current is coming out of a negative label while a positive current is located at a positive label.**

**FIG. 17**

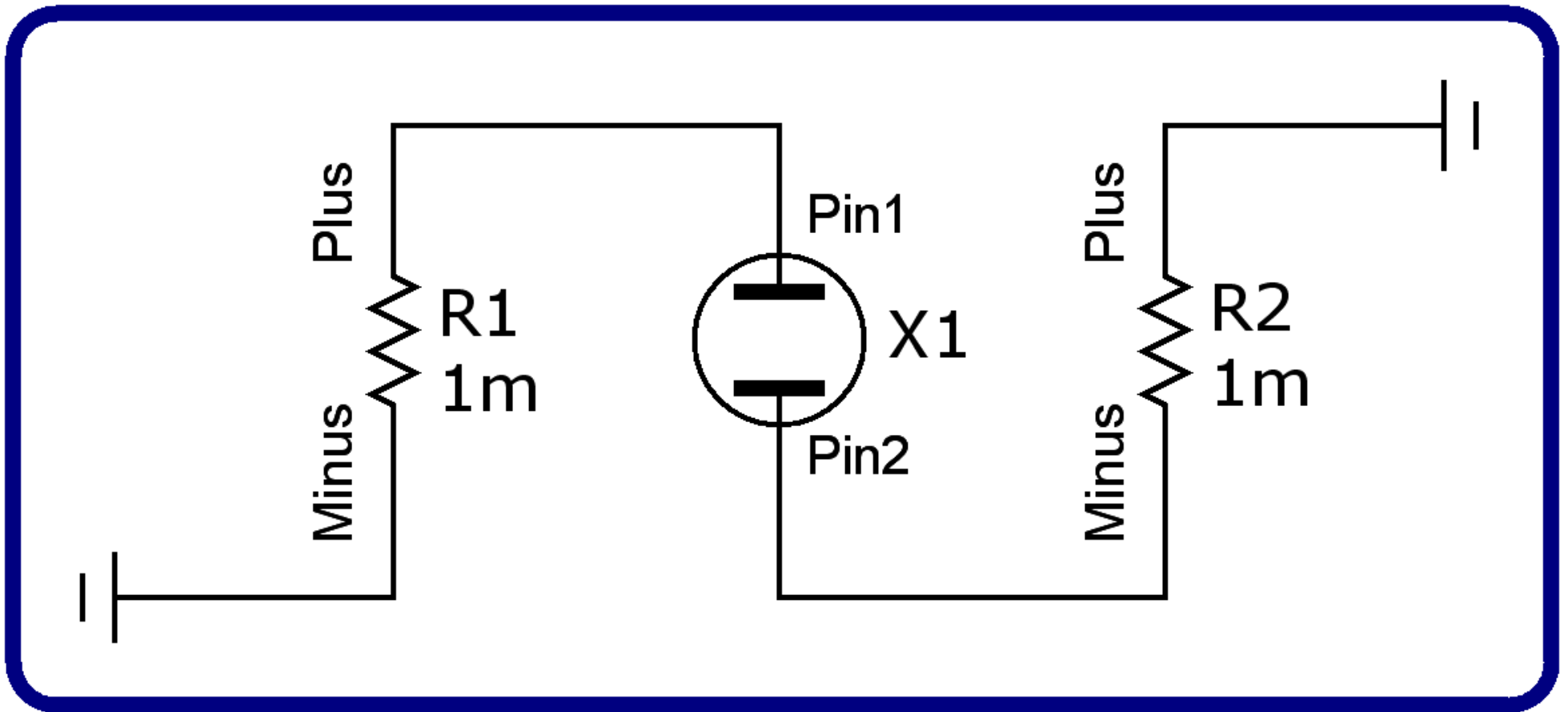

FIG. 18

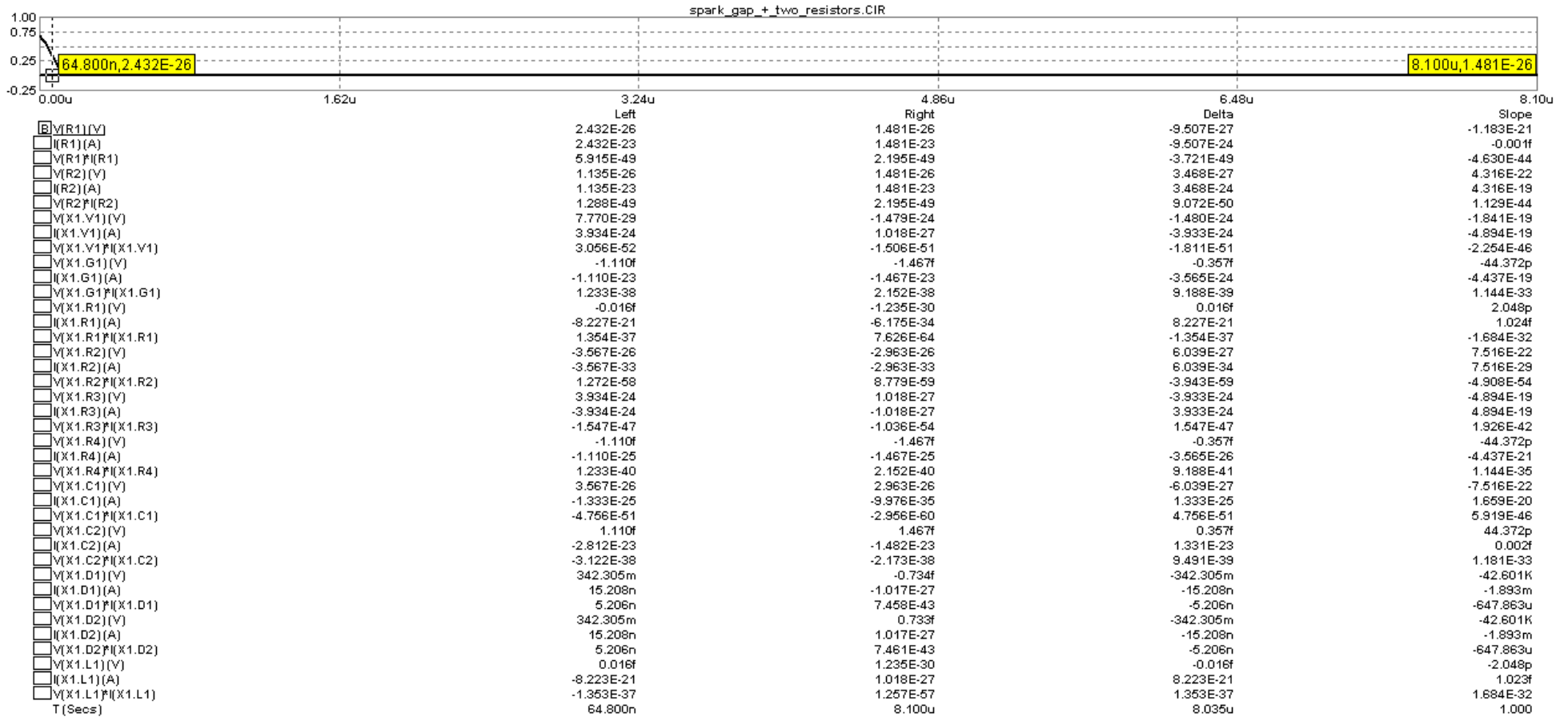

FIG. 19

## NEON BULB, SPARK GAP MACRO

.PARAMETERS(VTHRES=90, VARC=10, ISUS=500M,RNEG=-1,LPL=130N,RPL=2K,CPAR=1P,CARC=3P)

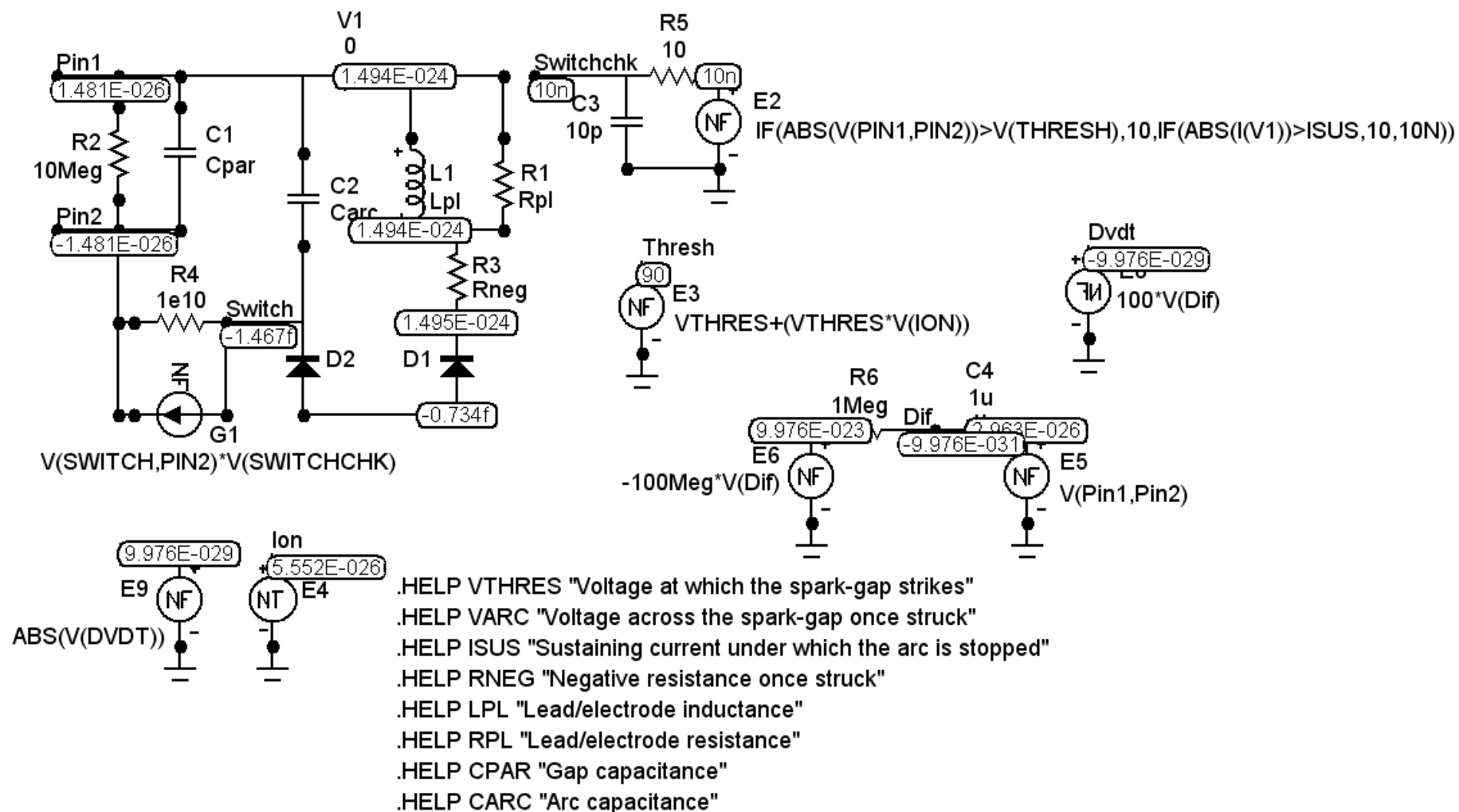
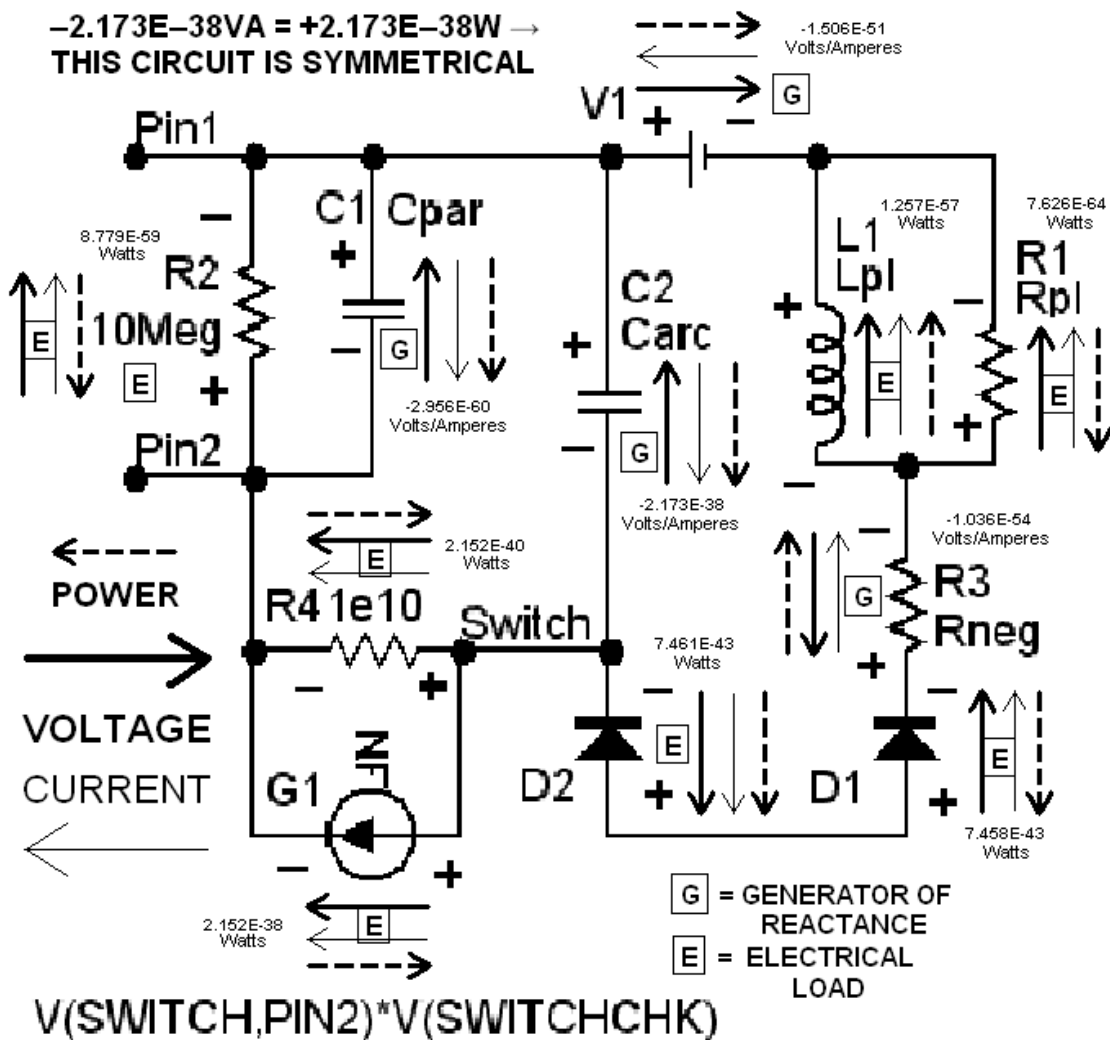

FIG. 20



SUB-TOTALS		RAW DATA	
<b>G</b>	Volts/Amperes	<input type="checkbox"/> V(R1)(V)	<input type="checkbox"/> V(X1.R4)(V)
		<input type="checkbox"/> I(R1)(A)	<input type="checkbox"/> I(X1.R4)(A)
		<input type="checkbox"/> V(R1)(R1)	<input type="checkbox"/> V(X1.R4)(X1.R4)
		<input type="checkbox"/> V(R2)(V)	<input type="checkbox"/> V(X1.C1)(V)
		<input type="checkbox"/> I(R2)(A)	<input type="checkbox"/> I(X1.C1)(A)
		<input type="checkbox"/> V(R2)(R2)	<input type="checkbox"/> V(X1.C1)(X1.C1)
		<input type="checkbox"/> V(X1.V1)(V)	<input type="checkbox"/> V(X1.C2)(V)
		<input type="checkbox"/> I(X1.V1)(A)	<input type="checkbox"/> I(X1.C2)(A)
		<input type="checkbox"/> V(X1.V1)(X1.V1)	<input type="checkbox"/> V(X1.C2)(X1.C2)
		<input type="checkbox"/> V(X1.G1)(V)	<input type="checkbox"/> V(X1.D1)(V)
		<input type="checkbox"/> I(X1.G1)(A)	<input type="checkbox"/> I(X1.D1)(A)
		<input type="checkbox"/> V(X1.G1)(X1.G1)	<input type="checkbox"/> V(X1.D1)(X1.D1)
		<input type="checkbox"/> V(X1.R1)(V)	<input type="checkbox"/> V(X1.D2)(V)
		<input type="checkbox"/> I(X1.R1)(A)	<input type="checkbox"/> I(X1.D2)(A)
		<input type="checkbox"/> V(X1.R1)(X1.R1)	<input type="checkbox"/> V(X1.L1)(V)
		<input type="checkbox"/> V(X1.R2)(V)	<input type="checkbox"/> I(X1.L1)(A)
		<input type="checkbox"/> I(X1.R2)(A)	<input type="checkbox"/> V(X1.L1)(X1.L1)
		<input type="checkbox"/> V(X1.R2)(X1.R2)	<input type="checkbox"/> T(Seconds)
		<input type="checkbox"/> V(X1.R3)(V)	
		<input type="checkbox"/> I(X1.R3)(A)	
		<input type="checkbox"/> V(X1.R3)(X1.R3)	

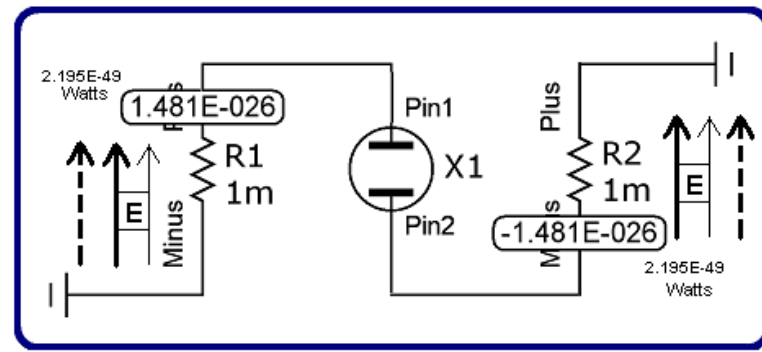

FIG. 21

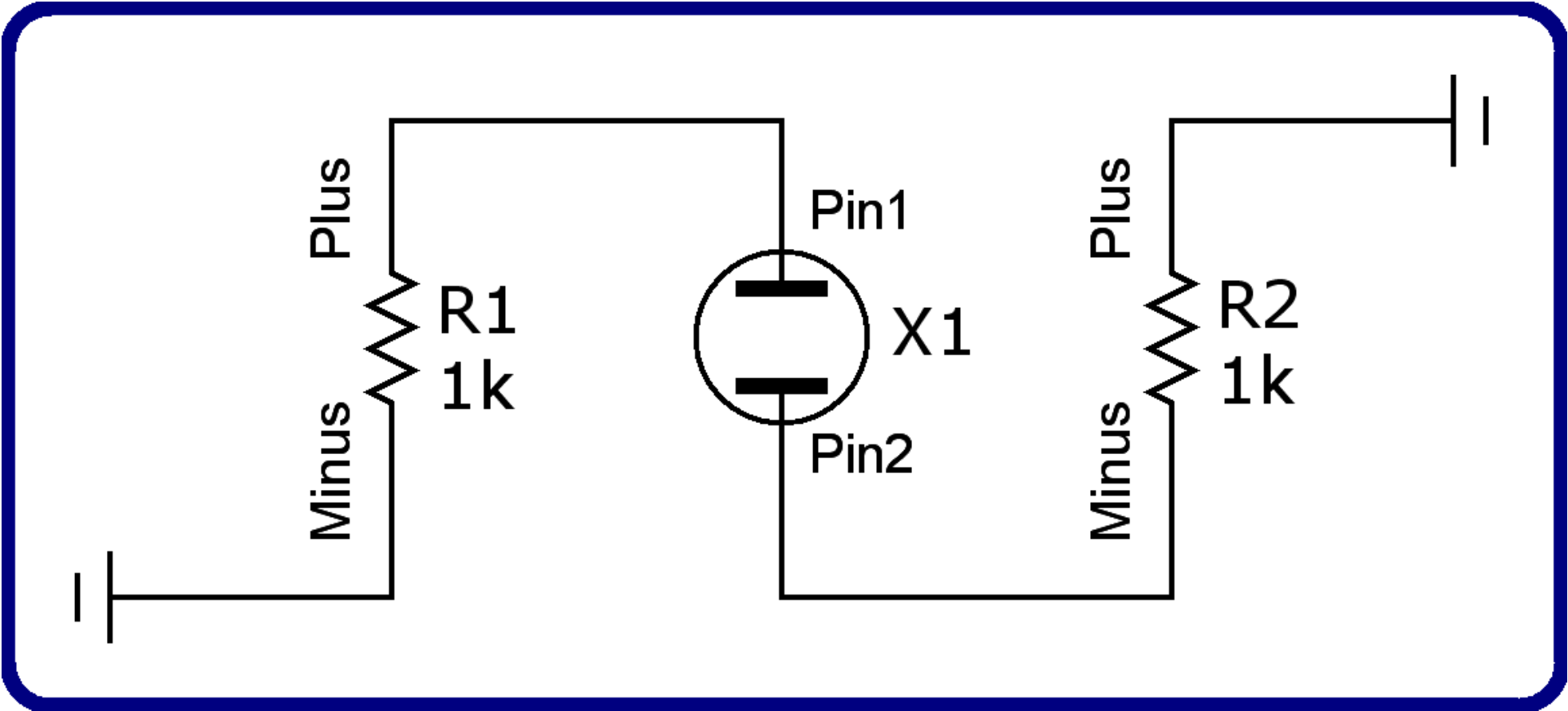

FIG. 22

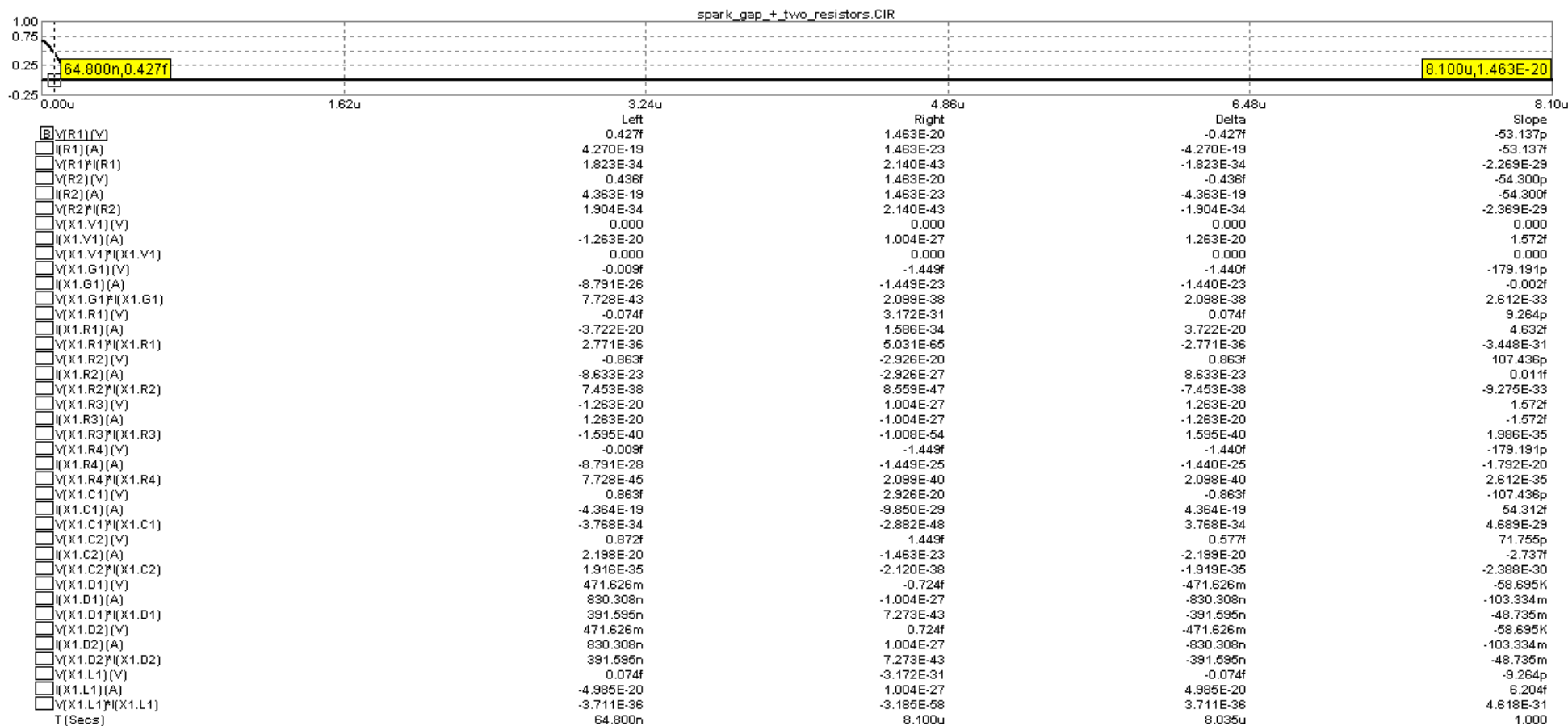

FIG. 23

## NEON BULB, SPARK GAP MACRO

.PARAMETERS(VTHRES=90, VARC=10, ISUS=500M,RNEG=-1,LPL=130N,RPL=2K,CPAR=1P,CARC=3P)

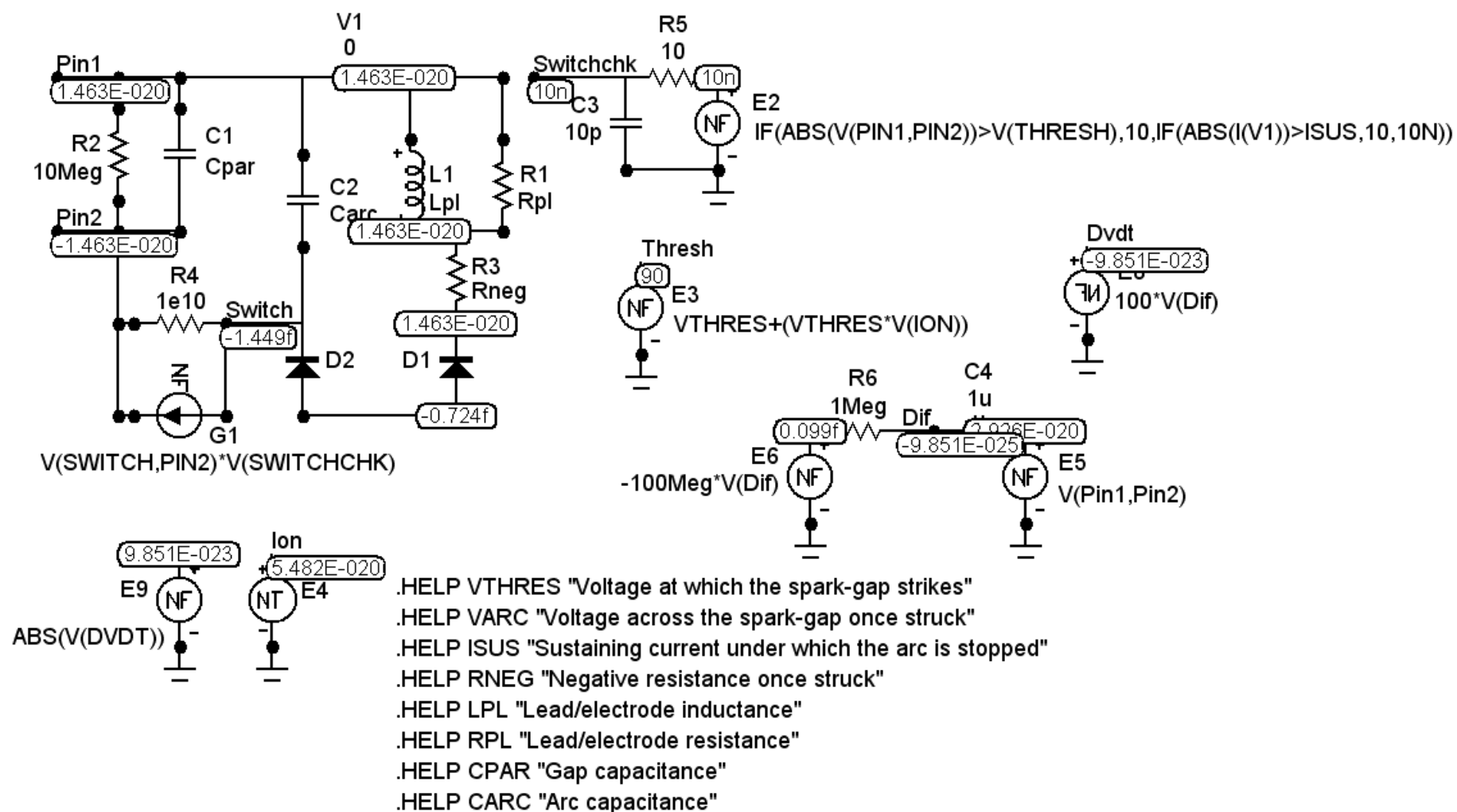
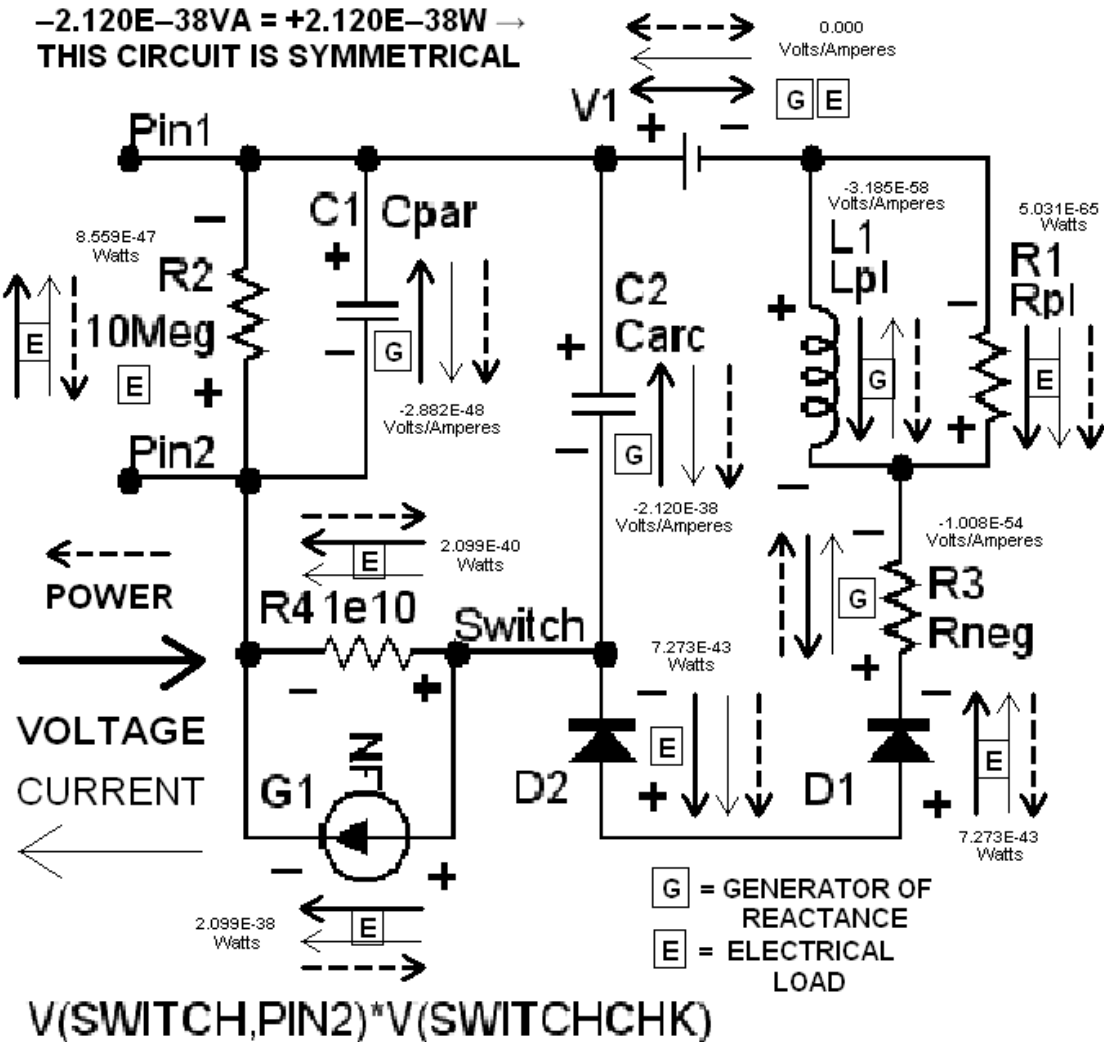

FIG. 24



$-2.120E-38VA = +2.120E-38W \rightarrow$   
**THIS CIRCUIT IS SYMMETRICAL**



SUB-TOTALS		RAW DATA	
0.000	2.099E-38	1.463E-20	V(X1.V1)(V)
-2.120E-38	2.099E-40	1.463E-23	I(R1)(A)
-2.882E-48	7.273E-43	2.140E-43	V(R1)(R1)
-1.008E-54	7.273E-43	1.463E-20	V(R2)(V)
-3.185E-58	2.140E-43	1.463E-23	I(R2)(A)
0.000	2.140E-43	2.140E-43	V(R2)(R2)
0.000	2.140E-43	0.000	V(X1.V1)(V)
0.000	2.140E-43	1.004E-27	I(X1.V1)(A)
0.000	2.140E-43	0.000	V(X1.V1)(X1.V1)
-1.449F	8.559E-47	-1.449F	V(X1.G1)(V)
-1.449E-23	2.099E-40	-1.449E-23	I(X1.G1)(A)
2.099E-38	2.099E-40	2.099E-38	V(X1.G1)(X1.G1)
-2.120E-38	2.099E-40	-2.120E-38	V(X1.C2)(V)
-0.724f	2.099E-40	-0.724f	I(X1.C2)(A)
-1.004E-27	2.099E-40	-1.004E-27	V(X1.D1)(V)
-1.004E-27	2.099E-40	-1.004E-27	I(X1.D1)(A)
7.273E-43	2.099E-40	7.273E-43	V(X1.D1)(X1.D1)
0.724f	2.099E-40	0.724f	V(X1.D2)(V)
1.004E-27	2.099E-40	1.004E-27	I(X1.D2)(A)
7.273E-43	2.099E-40	7.273E-43	V(X1.D2)(X1.D2)
-3.172E-31	2.099E-40	-3.172E-31	V(X1.L1)(V)
1.004E-27	2.099E-40	1.004E-27	I(X1.L1)(A)
-3.185E-58	2.099E-40	-3.185E-58	V(X1.L1)(X1.L1)
8.100u	2.099E-40	8.100u	T(Seconds)

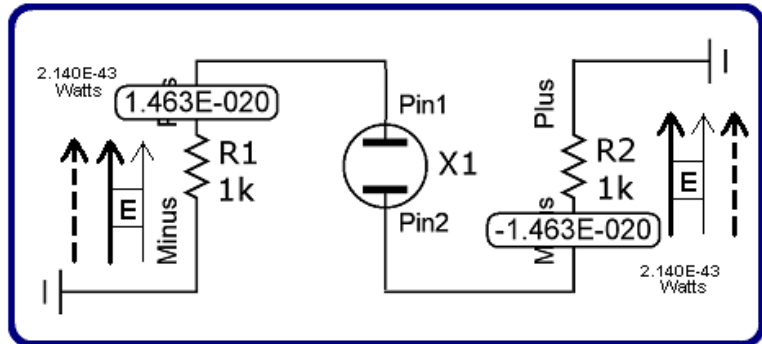

FIG. 25

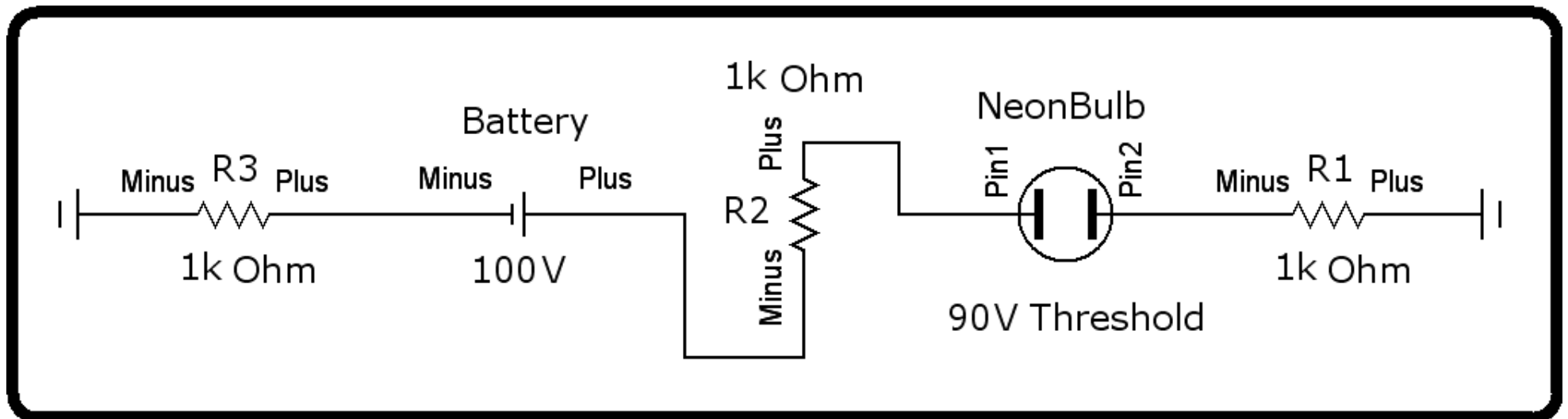

FIG. 26

100V\_Battery + Neon\_Bulb + One\_Kilo\_Ohm\_Of\_Resistance.CIR

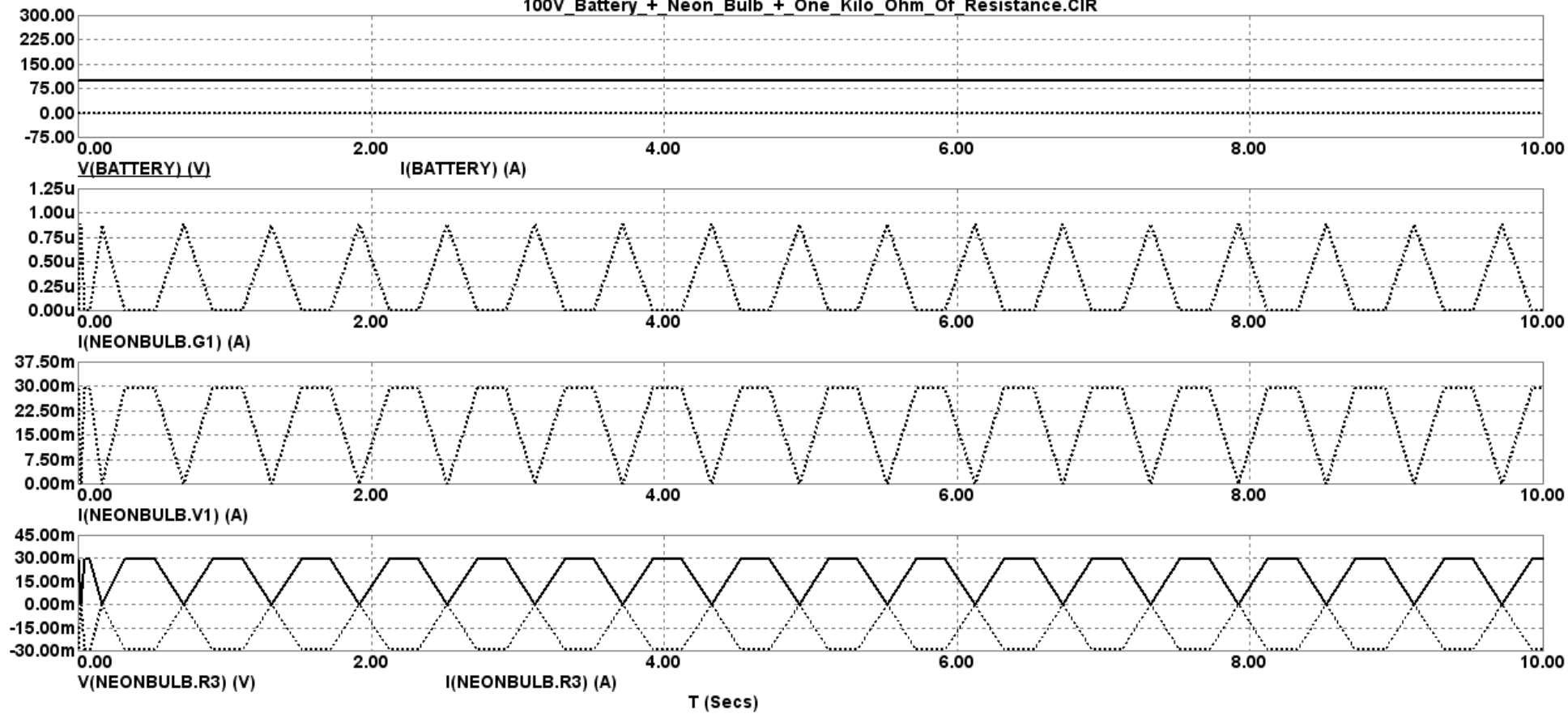

FIG. 27

	Left	Right	Delta	Slope
<input type="checkbox"/> V(BATTERY)(V)	100.000	100.000	0.000	0.000
<input type="checkbox"/> I(BATTERY)(A)	-29.431m	-29.448m	-17.305u	-1.737u
<input type="checkbox"/> V(BATTERY)*I(BATTERY)	-2.943	-2.945	-1.731m	-173.747u
<input type="checkbox"/> V(R1)(V)	-29.431	-29.448	-17.305m	-1.737m
<input type="checkbox"/> I(R1)(A)	-29.431m	-29.448m	-17.305u	-1.737u
<input type="checkbox"/> V(R1)*I(R1)	866.168m	867.187m	1.019m	102.300u
<input type="checkbox"/> V(R2)(V)	-29.431	-29.448	-17.305m	-1.737m
<input type="checkbox"/> I(R2)(A)	-29.431m	-29.448m	-17.305u	-1.737u
<input type="checkbox"/> V(R2)*I(R2)	866.168m	867.187m	1.019m	102.300u
<input type="checkbox"/> V(R3)(V)	-29.431	-29.448	-17.305m	-1.737m
<input type="checkbox"/> I(R3)(A)	-29.431m	-29.448m	-17.305u	-1.737u
<input type="checkbox"/> V(R3)*I(R3)	866.168m	867.187m	1.019m	102.300u
<input type="checkbox"/> V(NEONBULB.G1)(V)	5.933m	5.936m	3.042u	305.403n
<input type="checkbox"/> I(NEONBULB.G1)(A)	59.331p	59.361p	30.418f	3.054f
<input type="checkbox"/> V(NEONBULB.G1)*I(NEONBULB.G1)	352.011f	352.372f	0.361f	0.036f
<input type="checkbox"/> V(NEONBULB.V1)(V)	0.000	0.000	0.000	0.000
<input type="checkbox"/> I(NEONBULB.V1)(A)	29.430m	29.447m	17.306u	1.738u
<input type="checkbox"/> V(NEONBULB.V1)*I(NEONBULB.V1)	0.000	0.000	0.000	0.000
<input type="checkbox"/> V(NEONBULB.R1)(V)	-191.286n	5.429n	196.716n	19.751n
<input type="checkbox"/> I(NEONBULB.R1)(A)	-95.643p	2.715p	98.358p	9.875p
<input type="checkbox"/> V(NEONBULB.R1)*I(NEONBULB.R1)	0.018f	1.474E-20	-0.018f	-0.002f
<input type="checkbox"/> V(NEONBULB.R2)(V)	-11.708	-11.656	51.916m	5.212m
<input type="checkbox"/> I(NEONBULB.R2)(A)	-1.171u	-1.166u	5.192n	521.240p
<input type="checkbox"/> V(NEONBULB.R2)*I(NEONBULB.R2)	13.707u	13.586u	-121.294n	-12.178n
<input type="checkbox"/> V(NEONBULB.R3)(V)	29.430m	29.447m	17.306u	1.738u
<input type="checkbox"/> I(NEONBULB.R3)(A)	-29.430m	-29.447m	-17.306u	-1.738u
<input type="checkbox"/> V(NEONBULB.R3)*I(NEONBULB.R3)	-866.100u	-867.119u	-1.019u	-102.300n
<input type="checkbox"/> V(NEONBULB.R4)(V)	5.933m	5.936m	3.042u	305.403n
<input type="checkbox"/> I(NEONBULB.R4)(A)	593.305f	593.609f	0.304f	0.031f
<input type="checkbox"/> V(NEONBULB.R4)*I(NEONBULB.R4)	3.520f	3.524f	0.004f	3.625E-19
<input type="checkbox"/> V(NEONBULB.C1)(V)	11.708	11.656	-51.916m	-5.212m
<input type="checkbox"/> I(NEONBULB.C1)(A)	-4.413n	125.253p	4.538n	455.646p
<input type="checkbox"/> V(NEONBULB.C1)*I(NEONBULB.C1)	-51.666n	1.460n	53.126n	5.334n
<input type="checkbox"/> V(NEONBULB.C2)(V)	11.702	11.650	-51.919m	-5.213m
<input type="checkbox"/> I(NEONBULB.C2)(A)	44.041p	-2.925p	-46.966p	-4.715p
<input type="checkbox"/> V(NEONBULB.C2)*I(NEONBULB.C2)	515.357p	-34.078p	-549.435p	-55.164p
<input type="checkbox"/> V(NEONBULB.D1)(V)	-10.748	-10.722	25.946m	2.605m
<input type="checkbox"/> I(NEONBULB.D1)(A)	-885.564	-324.731	560.833	56.309
<input type="checkbox"/> V(NEONBULB.D1)*I(NEONBULB.D1)	9.518K	3.482K	-6.036K	-606.042
<input type="checkbox"/> V(NEONBULB.D2)(V)	983.420m	957.465m	-25.955m	-2.606m
<input type="checkbox"/> I(NEONBULB.D2)(A)	885.564	324.622	-560.942	-56.319
<input type="checkbox"/> V(NEONBULB.D2)*I(NEONBULB.D2)	870.881	310.814	-560.066	-56.232
<input type="checkbox"/> V(NEONBULB.L1)(V)	191.286n	-5.429n	-196.716n	-19.751n
<input type="checkbox"/> I(NEONBULB.L1)(A)	29.430m	29.447m	17.306u	1.738u
<input checked="" type="checkbox"/> V(NEONBULB.L1)*I(NEONBULB.L1)	5.629n	-159.874p	-5.789n	-581.260p
T(Secs)	40.000m	10.000	9.960	1.000

FIG. 28

## NEON BULB, SPARK GAP MACRO

.PARAMETERS(VTHRES=90, VARC=10, ISUS=500M,RNEG=-1,LPL=130N,RPL=2K,CPAR=1P,CARC=3P)

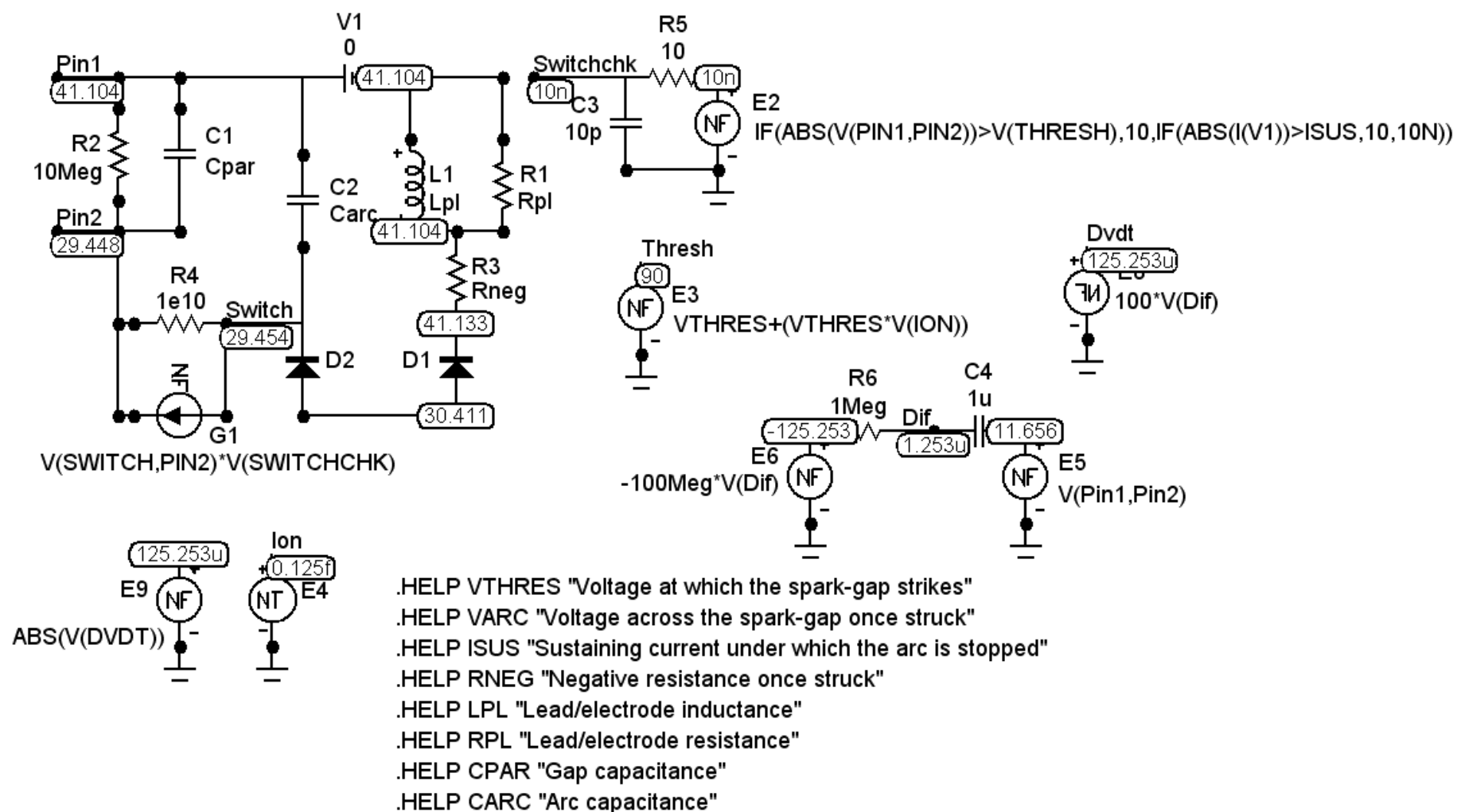

FIG. 29

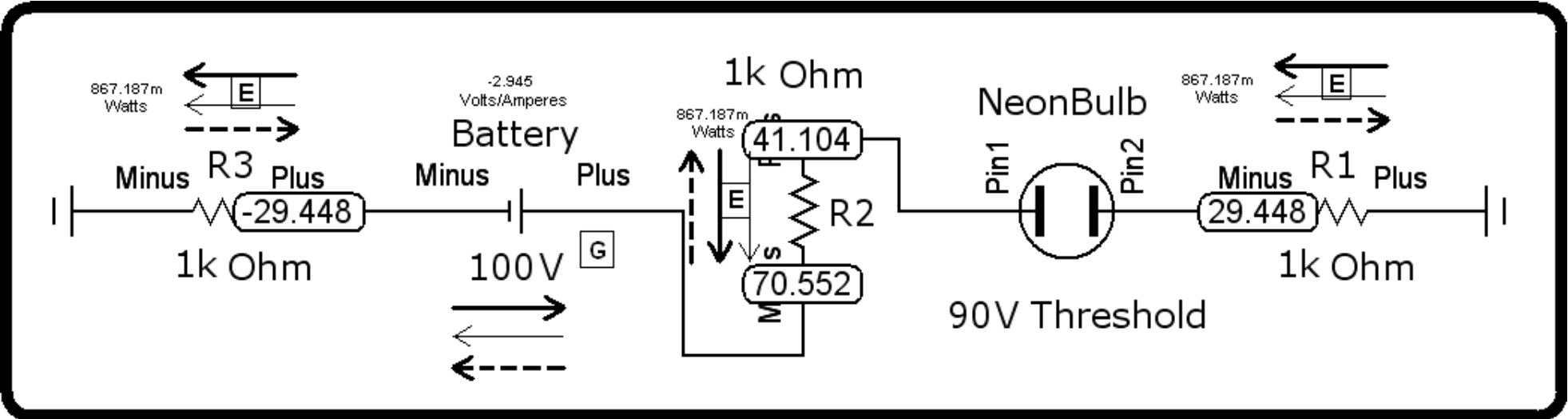
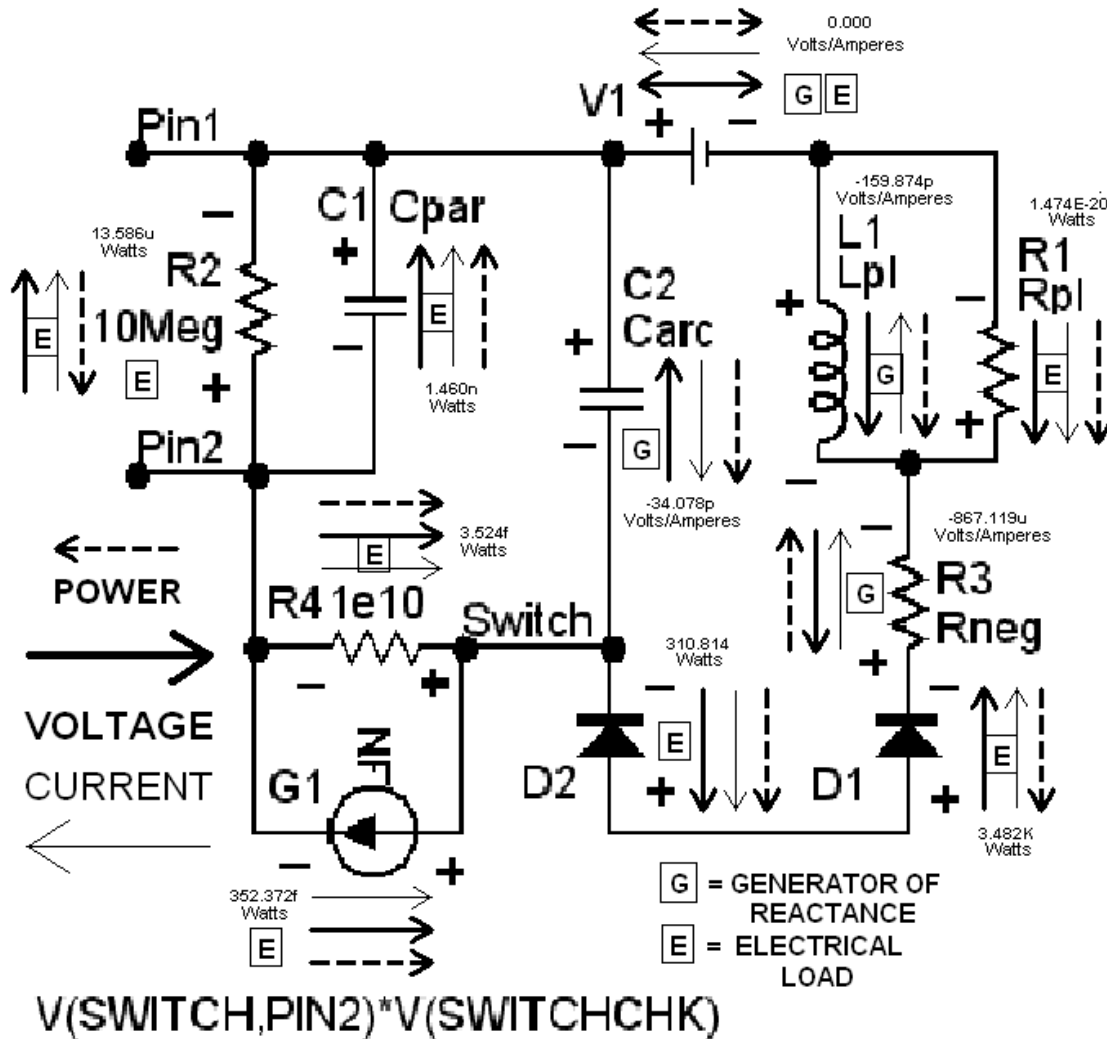

FIG. 30



**-2.945VA ≠ +3.7928KW → THIS CIRCUIT IS ASYMMETRICAL BY A FACTOR OF → +1,287.83W TO -1VA**

Value	Component	Value	Component
867.187m	V(R1)(R1)	3.482K	
867.187m	V(R2)(R2)	310.814	
867.187m	V(R3)(R3)	867.187m	
-2.945	V(BATTERY)(BATTERY)	867.187m	
352.372f	V(NEONBULB.G1)(NEONBULB.G1)	13.586u	
0.000	V(NEONBULB.V1)(NEONBULB.V1)	1.460n	
1.474E-20	V(NEONBULB.R1)(NEONBULB.R1)	352.372f	
13.586u	V(NEONBULB.R2)(NEONBULB.R2)	3.524f	
-867.119u	V(NEONBULB.R3)(NEONBULB.R3)	1.474E-20	
3.524f	V(NEONBULB.R4)(NEONBULB.R4)	0.000	
1.460n	V(NEONBULB.C1)(NEONBULB.C1)	100.000	V(BATTERY)(V)
-34.078p	V(NEONBULB.C2)(NEONBULB.C2)	-29.448m	I(BATTERY)(A)
3.482K	V(NEONBULB.D1)(NEONBULB.D1)	5.936m	V(NEONBULB.G1)(V)
310.814	V(NEONBULB.D2)(NEONBULB.D2)	59.361p	I(NEONBULB.G1)(A)
-159.874p	V(NEONBULB.L1)(NEONBULB.L1)	0.000	V(NEONBULB.V1)(V)
11.650	V(NEONBULB.C2)(V)	29.447m	I(NEONBULB.V1)(A)
-2.925p	I(NEONBULB.C2)(A)	5.429n	V(NEONBULB.R1)(V)
-10.722	V(NEONBULB.D1)(V)	2.715p	I(NEONBULB.R1)(A)
-324.731	I(NEONBULB.D1)(A)	-11.656	V(NEONBULB.R2)(V)
957.465m	V(NEONBULB.D2)(V)	-1.166u	I(NEONBULB.R2)(A)
324.622	I(NEONBULB.D2)(A)	29.447m	V(NEONBULB.R3)(V)
-5.429n	V(NEONBULB.L1)(V)	-29.447m	I(NEONBULB.R3)(A)
29.447m	I(NEONBULB.L1)(A)	5.936m	V(NEONBULB.R4)(V)
		593.609f	I(NEONBULB.R4)(A)
		11.656	V(NEONBULB.C1)(V)
		125.253p	I(NEONBULB.C1)(A)

Value	Component	Value	Component
-2.945		3.482K	
-867.119u		310.814	
-34.078p		867.187m	
-159.874p		867.187m	
0.000		13.586u	
-2.945		1.460n	
		352.372f	
		3.524f	
		1.474E-20	
		0.000	
		<b>+3.7928k</b>	

**FIG. 31**

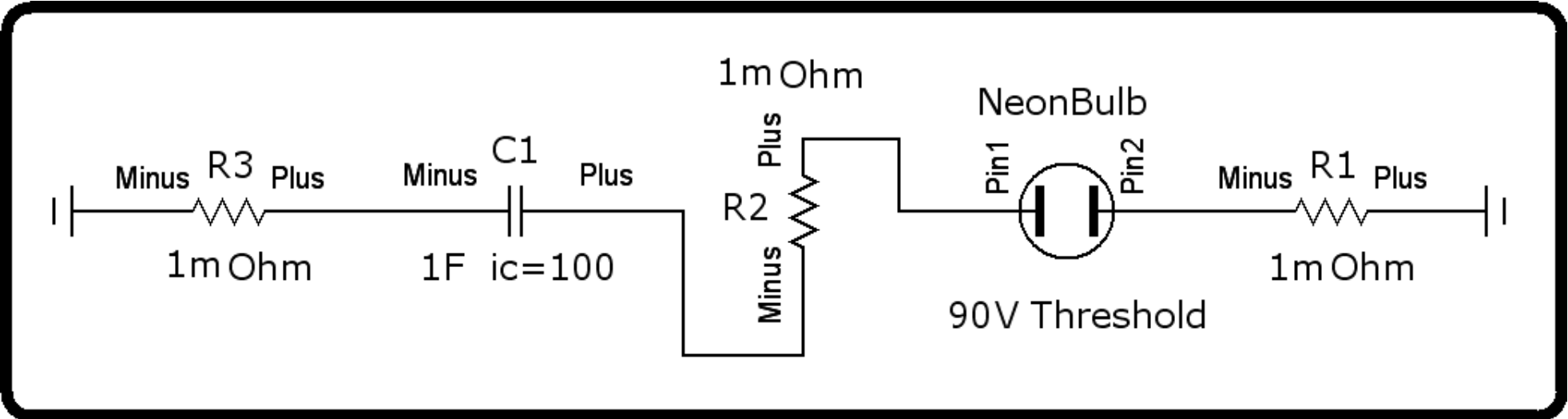

FIG. 32



Precharged\_Capacitor + Neon\_Bulb + One\_Milli\_Ohm\_Of\_Resistance.CIR

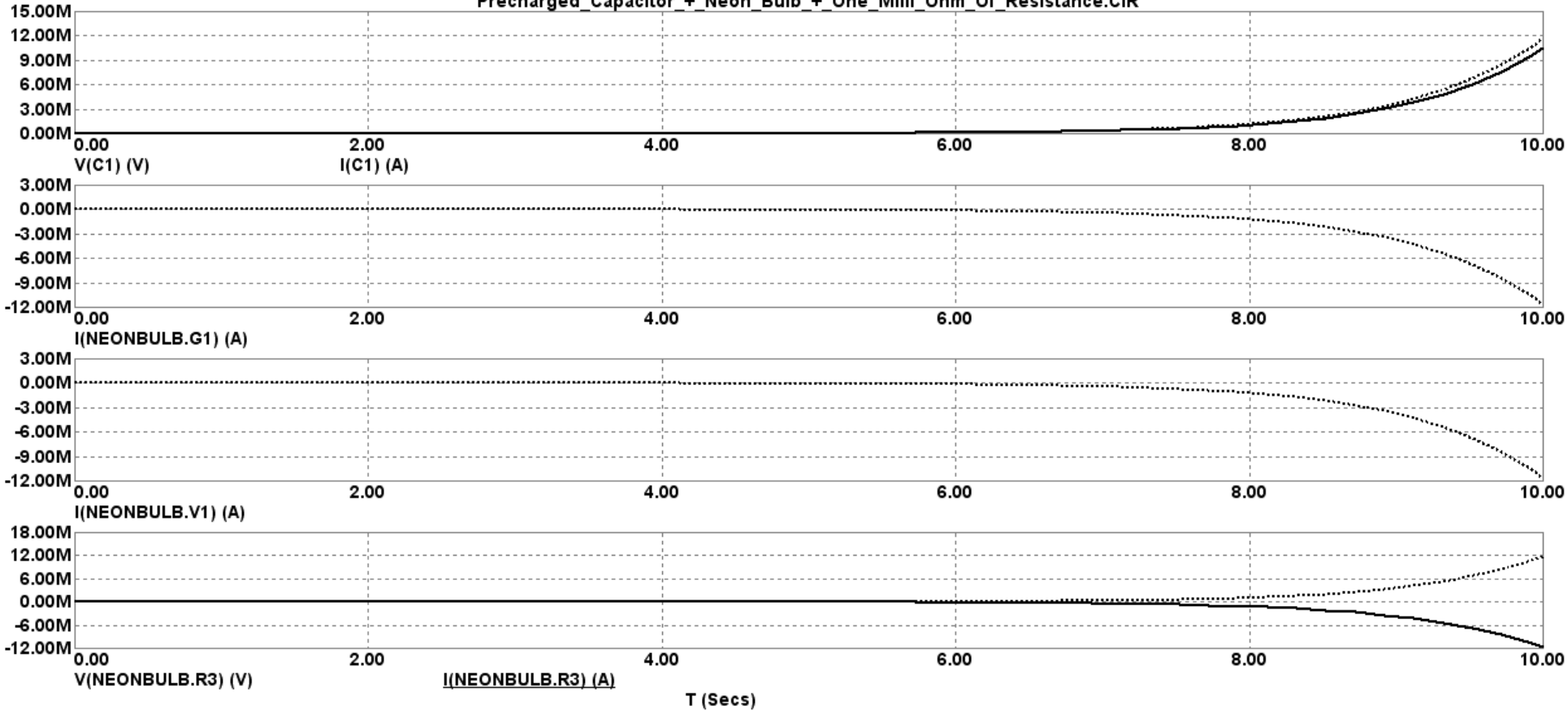

FIG. 33

Precharged\_Capacitor + Neon Bulb + One Milli\_Ohm\_Of\_Resistance.CIR

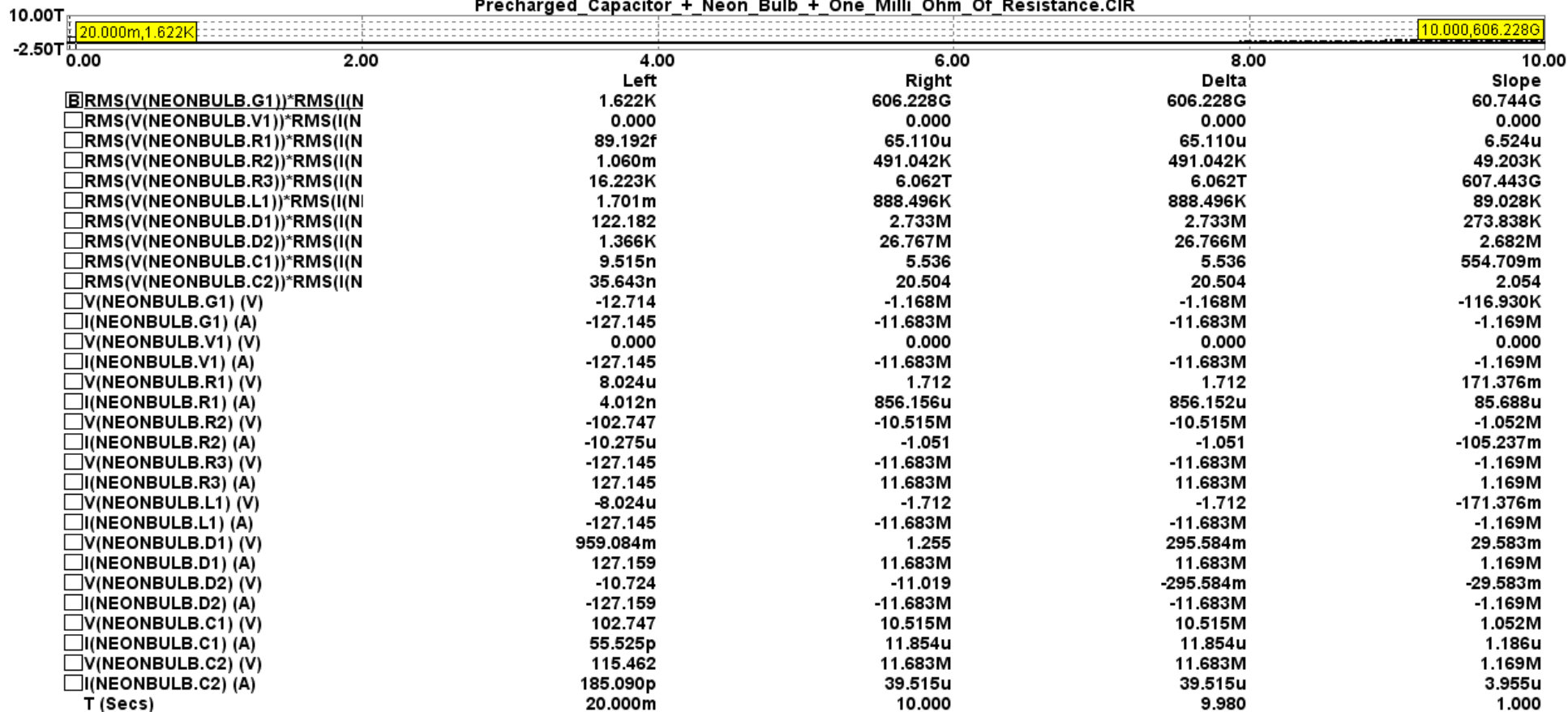

FIG. 34

Precharged\_Capacitor+\_Neon\_Bulb+\_One\_Milli\_Ohm\_Of\_Resistance.CIR

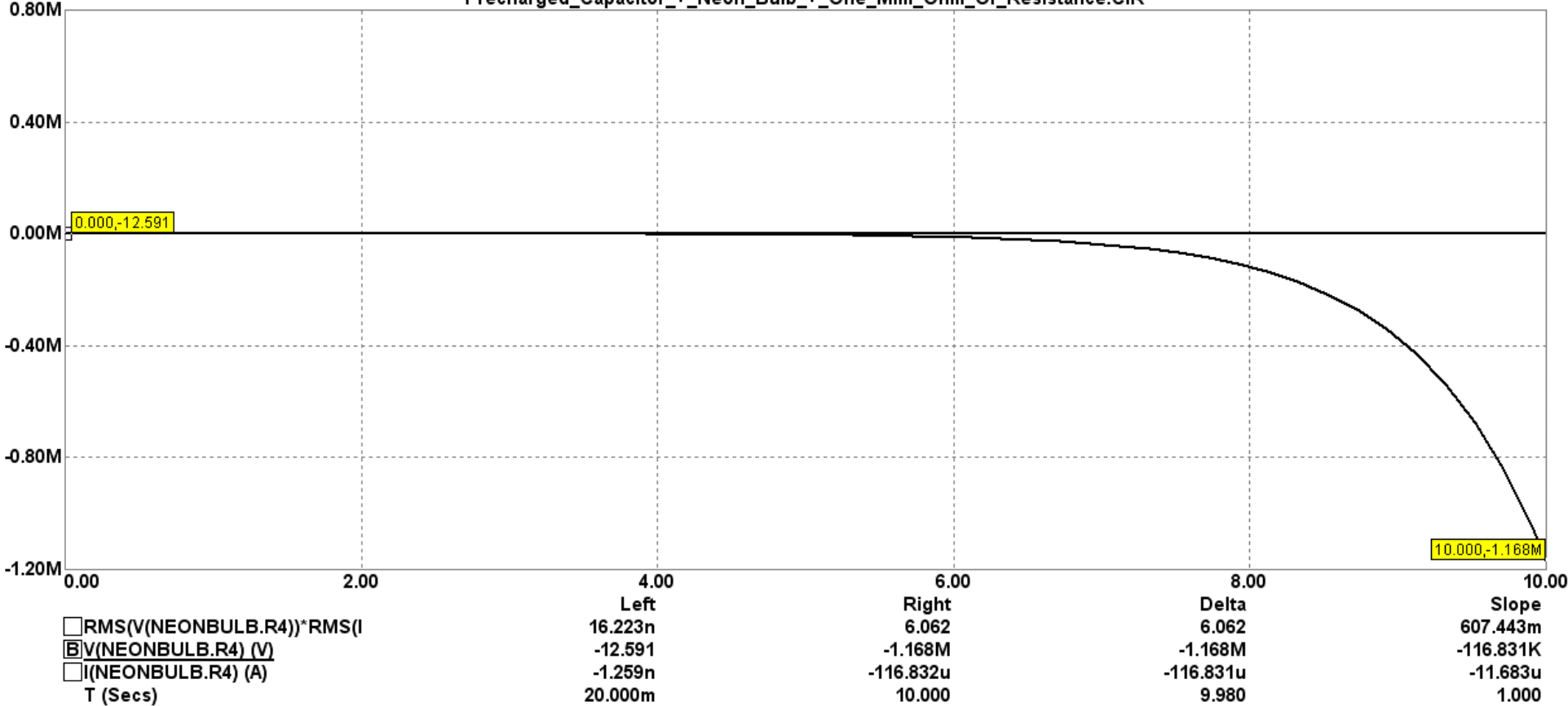
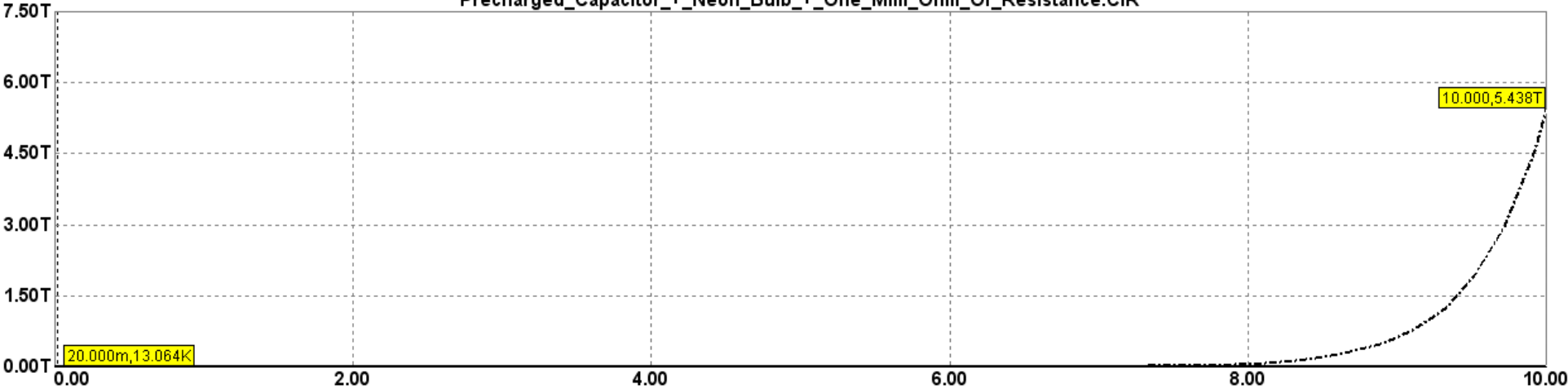

FIG. 35

Precharged\_Capacitor + Neon\_Bulb + One\_Milli\_Ohm\_Of\_Resistance.CIR



	Left	Right	Delta	Slope
<input checked="" type="checkbox"/> RMS(V(C1))*RMS(I(C1))	13.064K	5.438T	5.438T	544.875G
<input type="checkbox"/> RMS(V(R1))*RMS(I(R1))	16.223	6.062G	6.062G	607.443M
<input type="checkbox"/> RMS(V(R2))*RMS(I(R2))	16.223	6.062G	6.062G	607.443M
<input type="checkbox"/> RMS(V(R3))*RMS(I(R3))	16.223	6.062G	6.062G	607.443M
<input type="checkbox"/> V(C1) (V)	102.362	10.480M	10.480M	1.049M
<input type="checkbox"/> I(C1) (A)	127.140	11.683M	11.683M	1.169M
<input type="checkbox"/> V(R1) (V)	127.140m	11.683K	11.683K	1.169K
<input type="checkbox"/> I(R1) (A)	127.140	11.683M	11.683M	1.169M
<input type="checkbox"/> V(R2) (V)	127.140m	11.683K	11.683K	1.169K
<input type="checkbox"/> I(R2) (A)	127.140	11.683M	11.683M	1.169M
<input type="checkbox"/> V(R3) (V)	127.140m	11.683K	11.683K	1.169K
<input type="checkbox"/> I(R3) (A)	127.140	11.683M	11.683M	1.169M
T (Secs)	20.000m	10.000	9.980	1.000

FIG. 36

## NEON BULB, SPARK GAP MACRO

.PARAMETERS(VTHRES=90, VARC=10, ISUS=500M,RNEG=-1,LPL=130N,RPL=2K,CPAR=1P,CARC=3P)

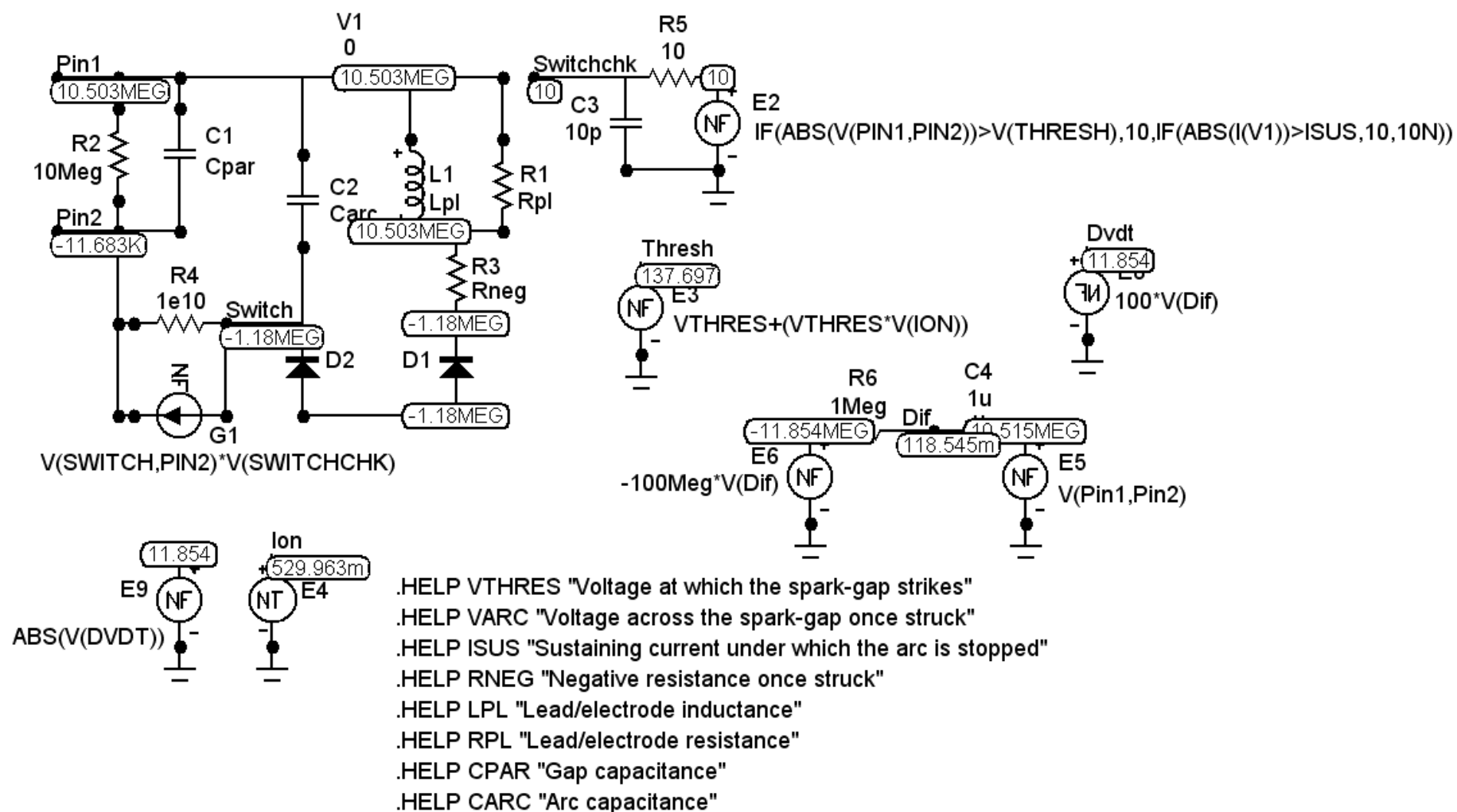

FIG. 37

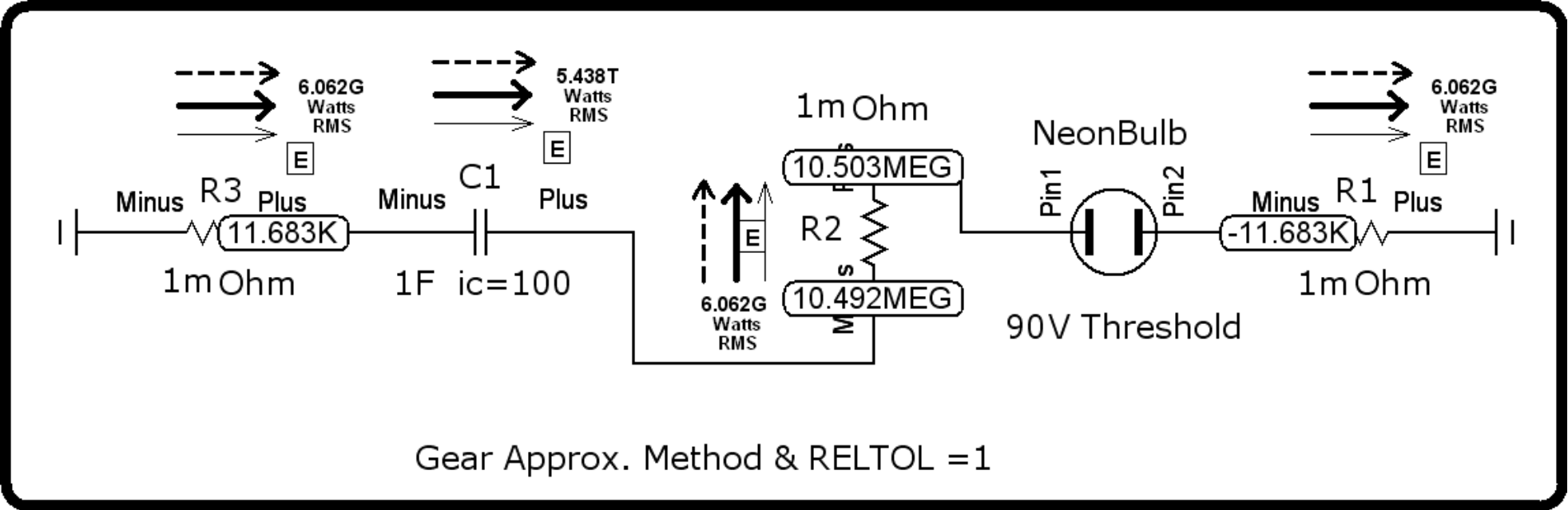
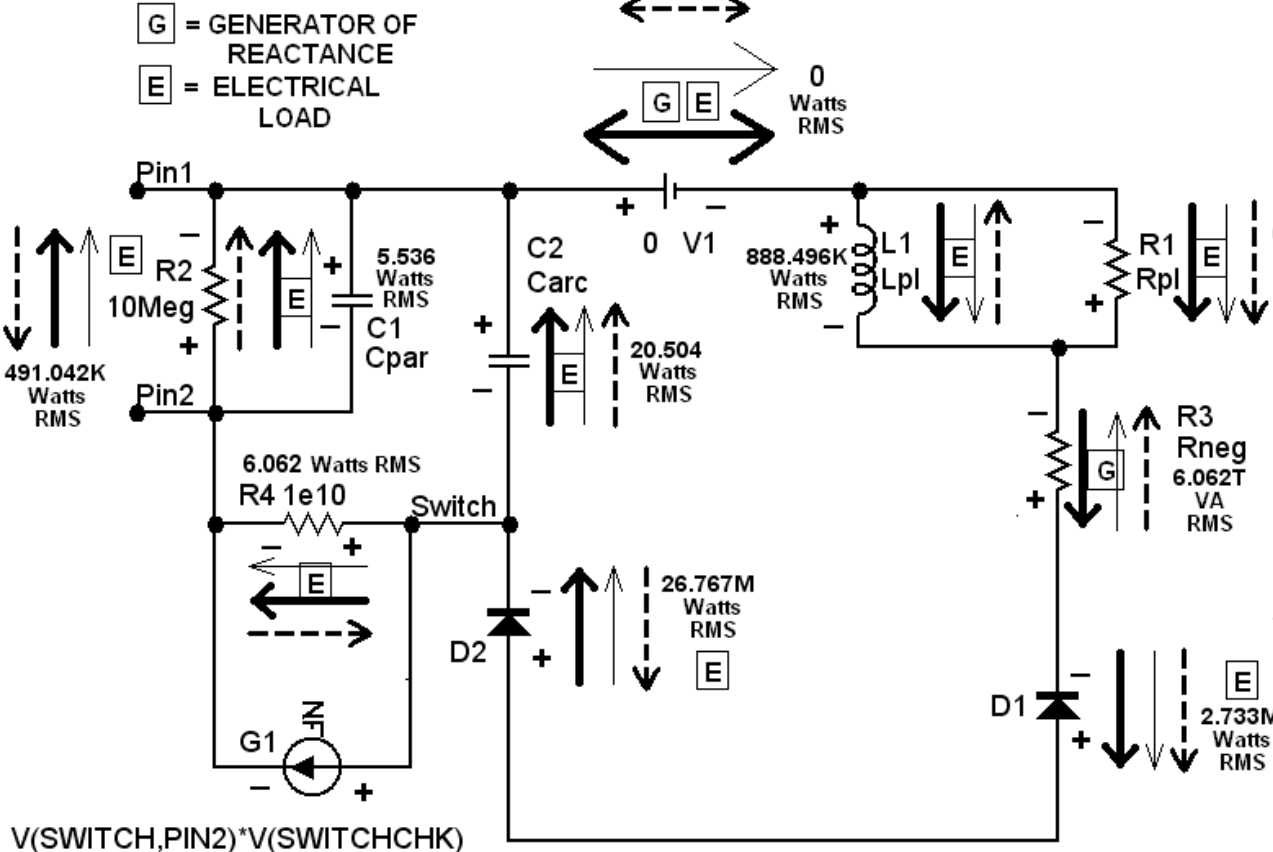

FIG. 38

**G** = GENERATOR OF REACTANCE  
**E** = ELECTRICAL LOAD



-6.062T	+606.228G
0	+26.767M
-6.062T	+2.733M
	+888.496K
	+491.042K
	+20.504
	+6.062
	+5.536
	+65.110u
	0
	+606.258G
	<b>Watts RMS</b>
<hr/>	
0	+5.438T
0	+6.062G
	+6.062G
	+6.062G
	+5.456T
	<b>Watts RMS</b>
<hr/>	
<b>TOTAL</b>	
-6.062T VOLTS/AMPERES	
+606.258G WATTS	
+5.456T WATTS	
<hr/>	
+0.000258T WATTS	
+258 Mega Watts?	

$V(\text{SWITCH}, \text{PIN2}) * V(\text{SWITCHCHK})$



**THIS CIRCUIT IS ASYMMETRICAL BY A SMALL %...** → see next two slides...

**FIG. 39**

Precharged\_Capacitor+\_Neon\_Bulb+\_One\_Milli\_Ohm\_Of\_Resistance.CIR

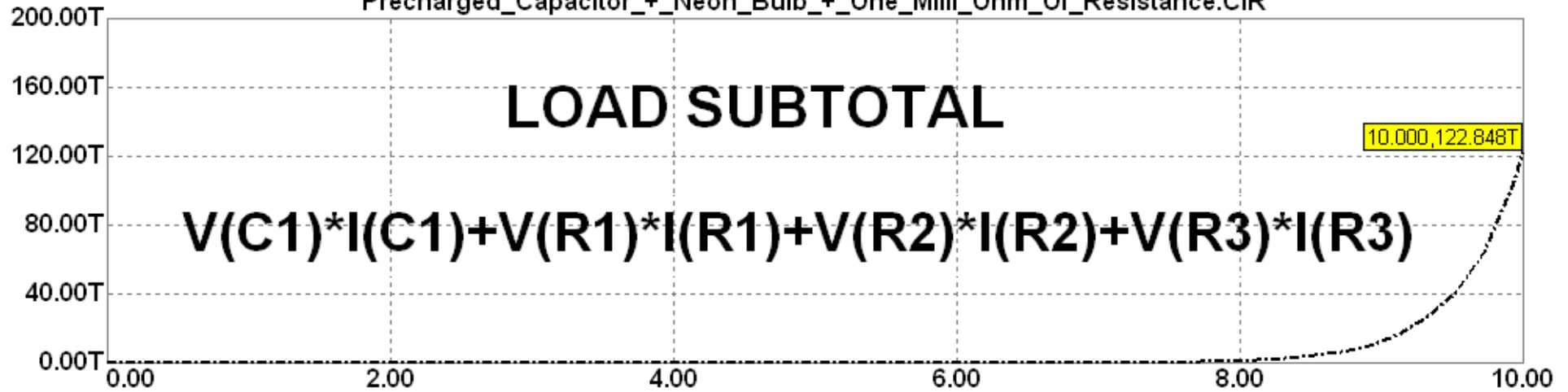

	Left	Right	Delta	Slope
$V(C1)*I(C1)+V(R1)*I(R1)$	122.848T	122.848T	0.000	INF
T (Secs)	10.000	10.000	0.000	1.000

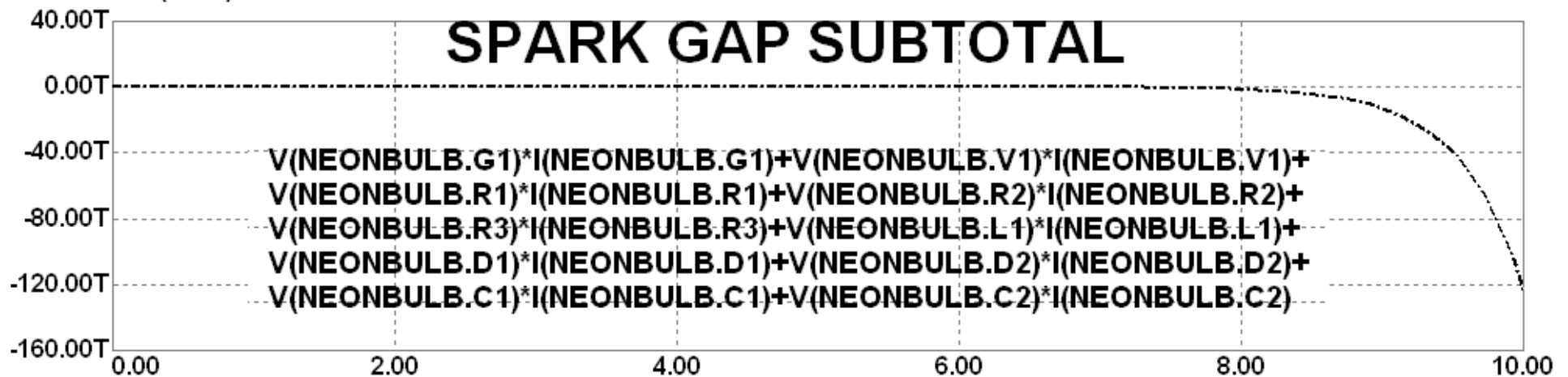

	Left	Right	Delta	Slope
$V(NEONBULB.G1)*I(N$	-122.848T	-122.848T	0.000	INF
T (Secs)	10.000	10.000	0.000	1.000

FIG. 40



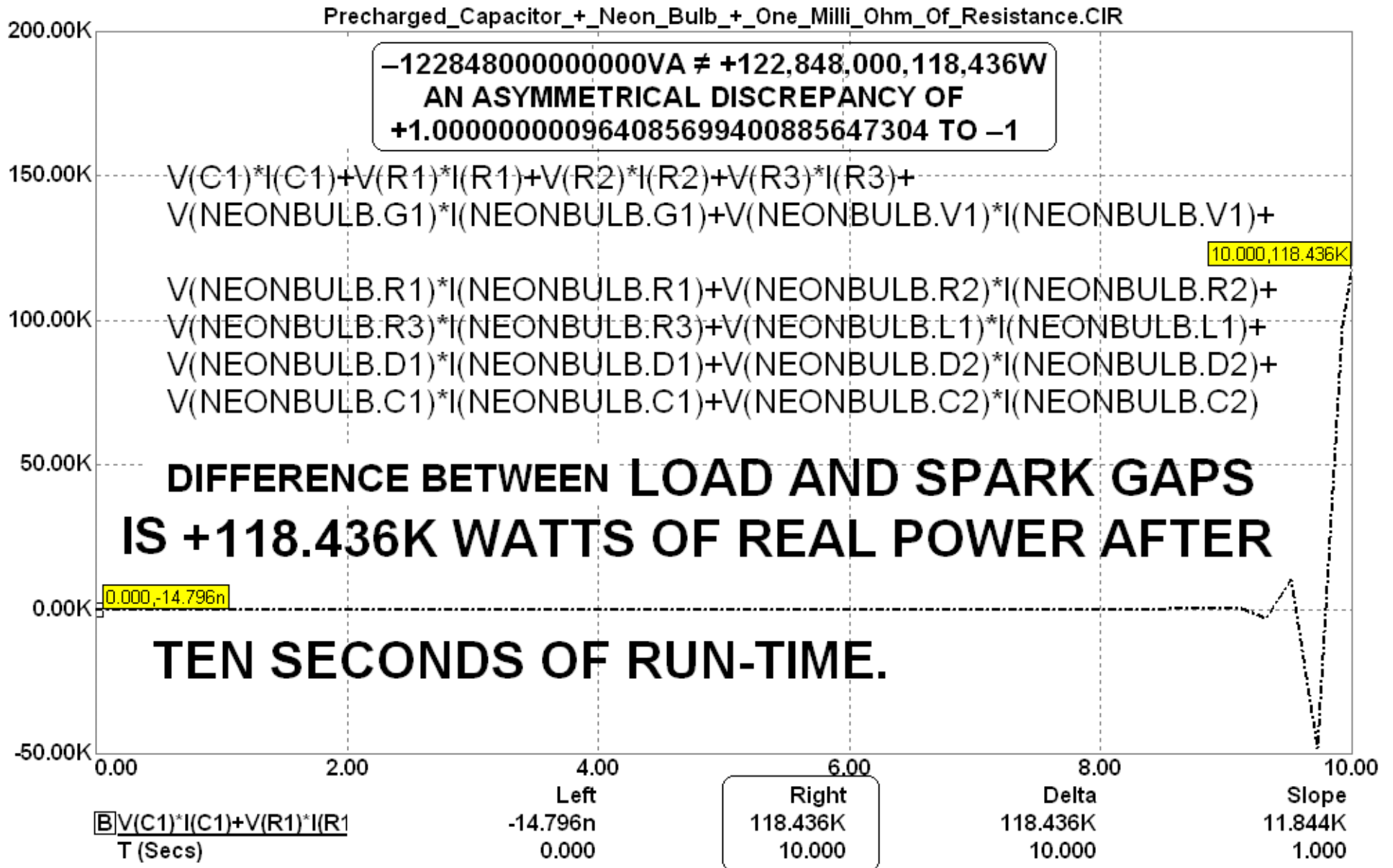

FIG. 41

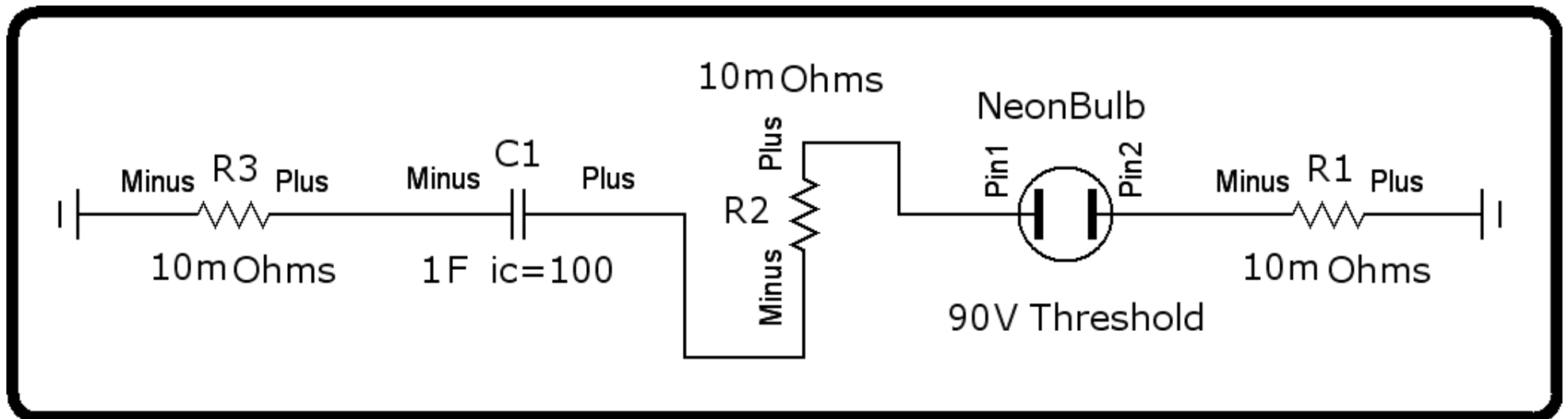

FIG. 42

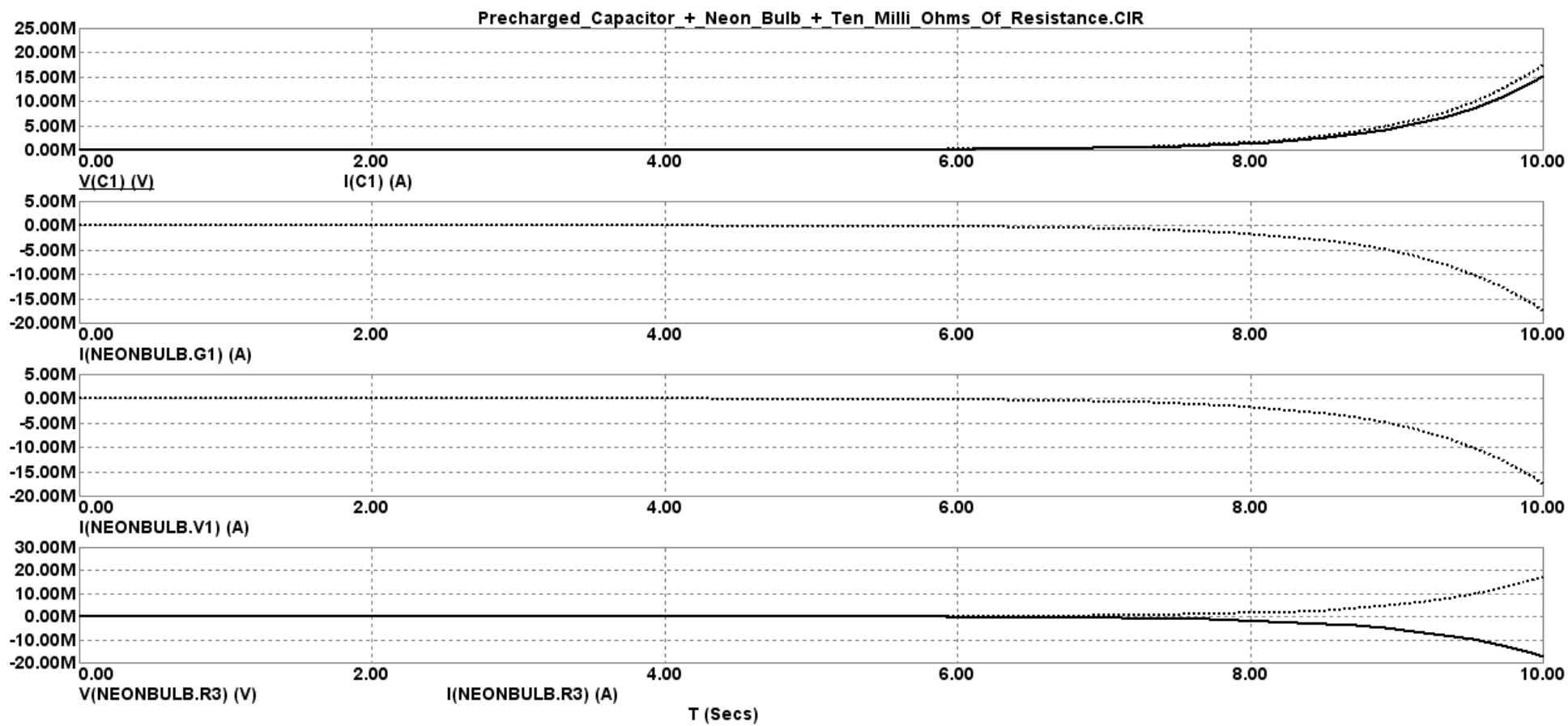

FIG. 43

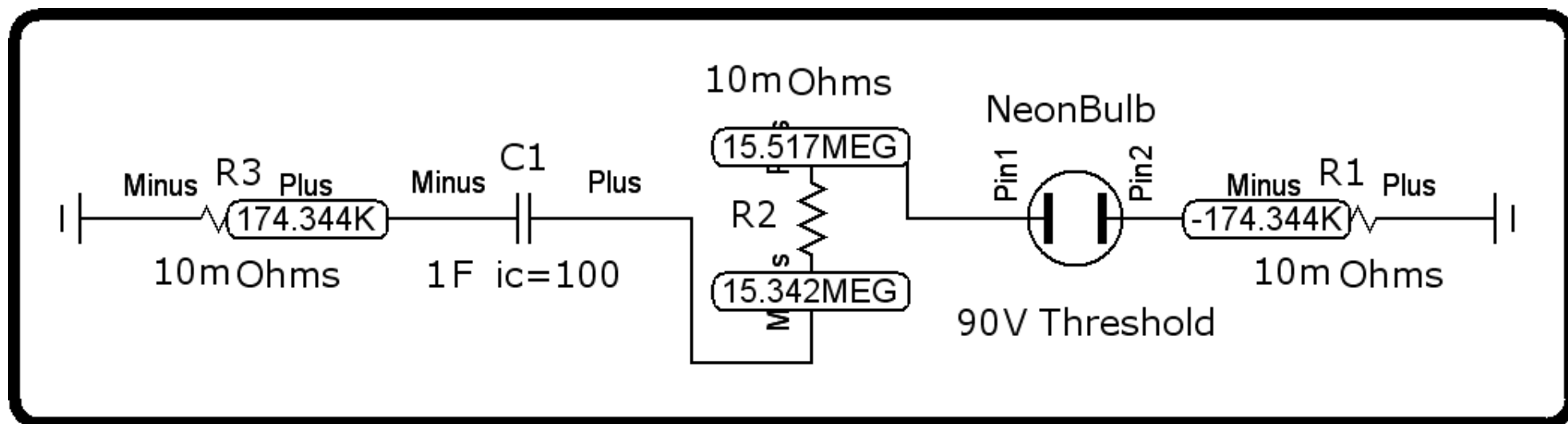

FIG. 44

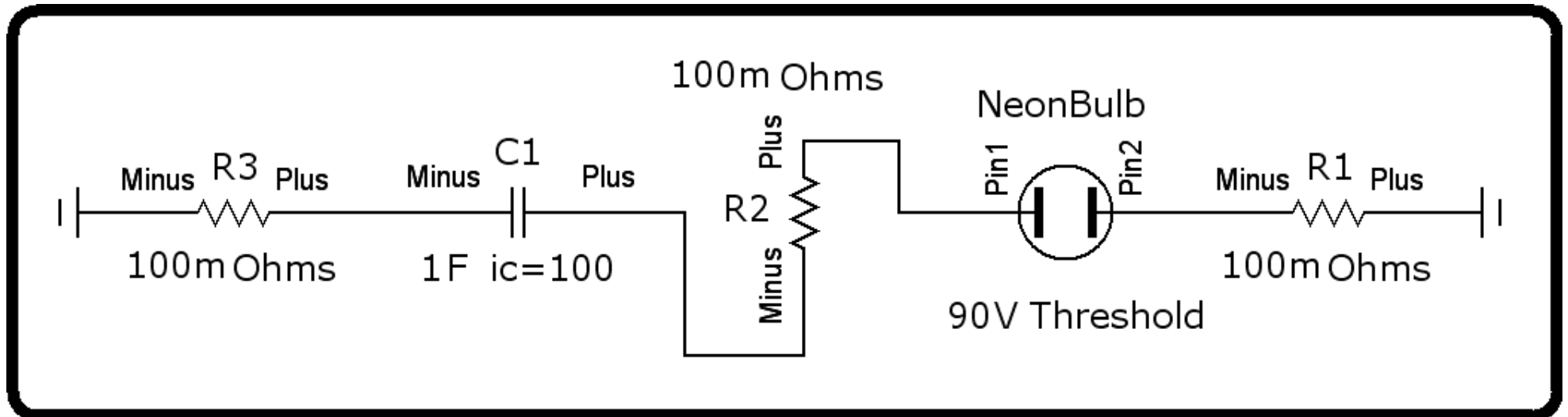

FIG. 45

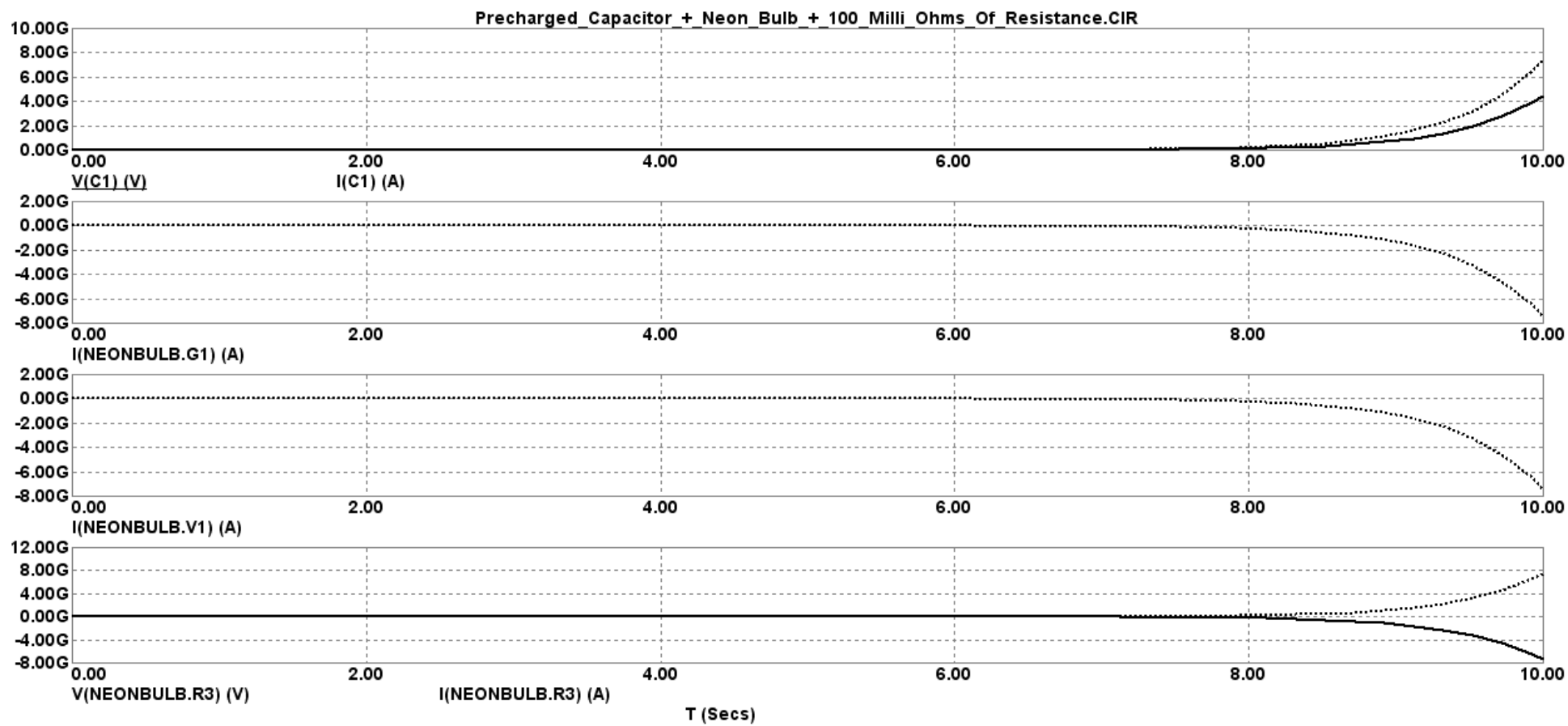

FIG. 46

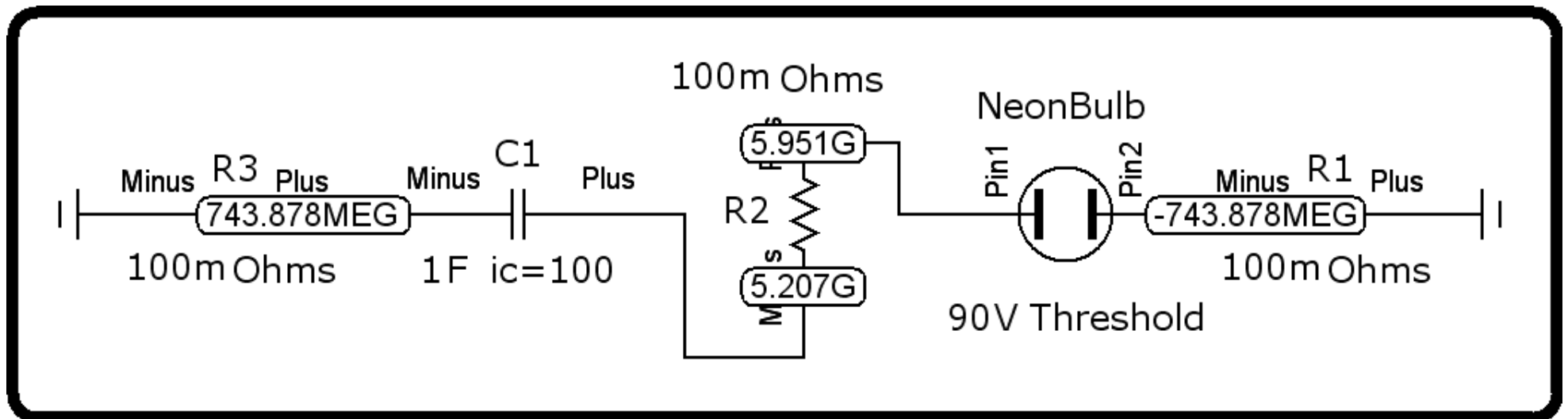

FIG. 47

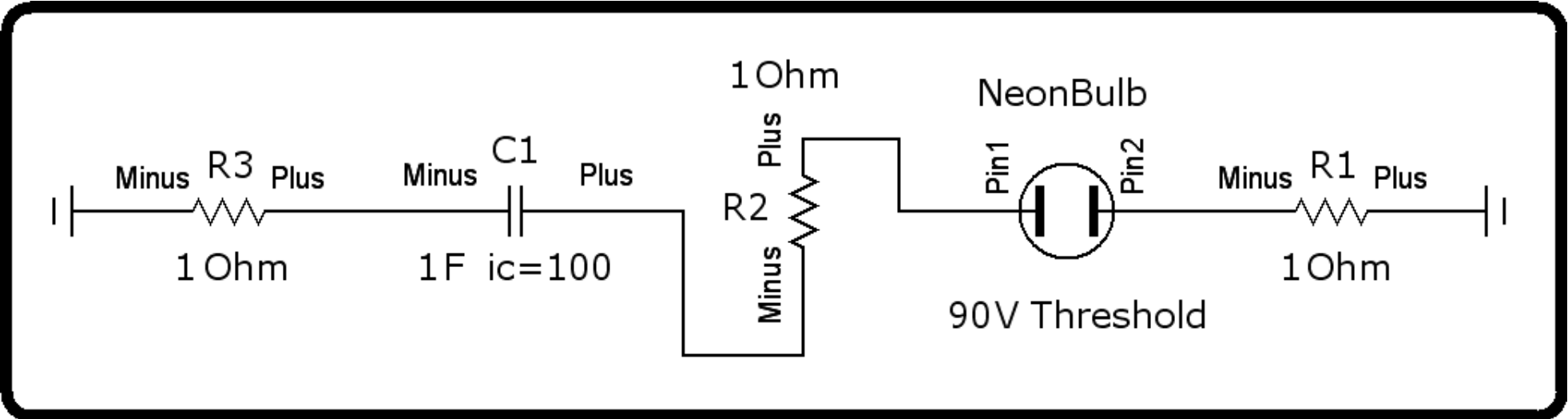

FIG. 48



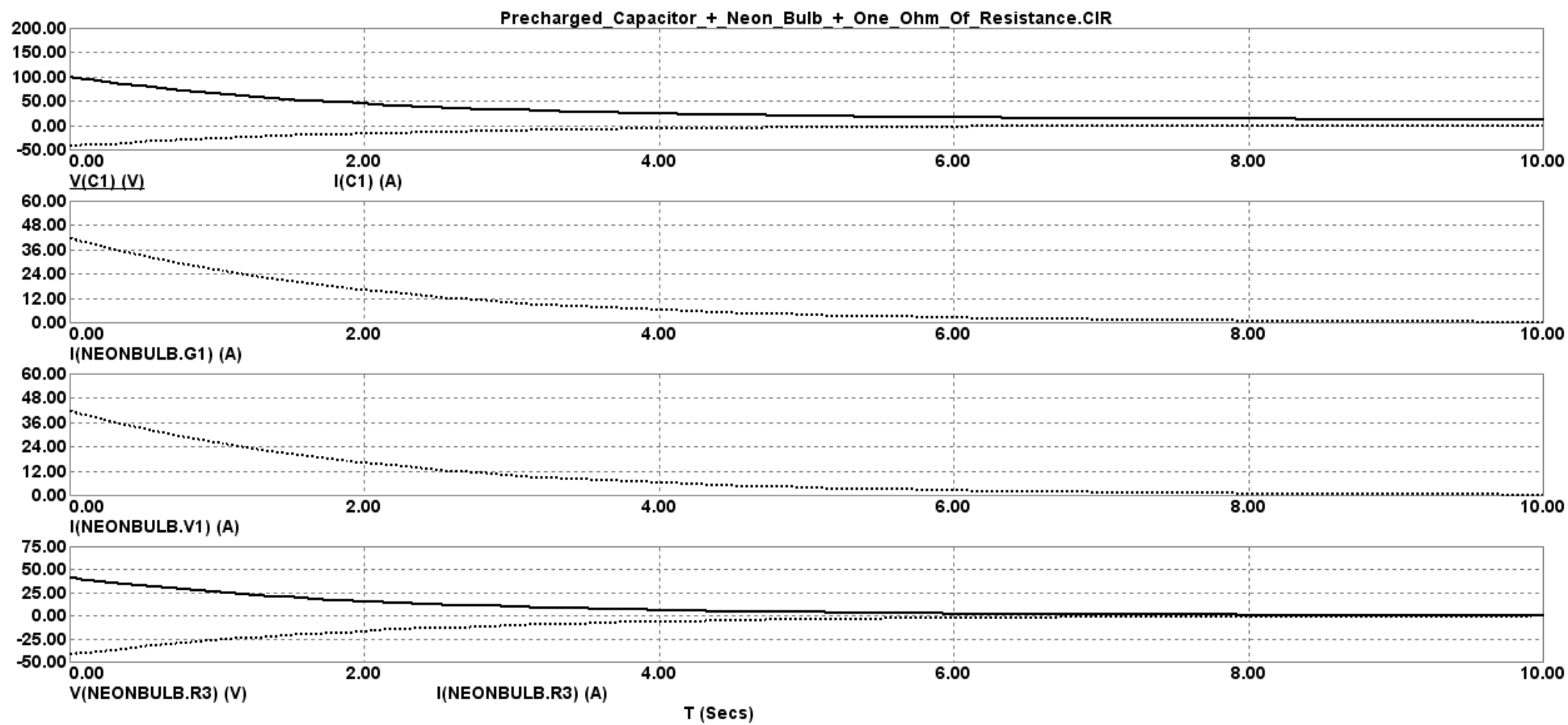

FIG. 49

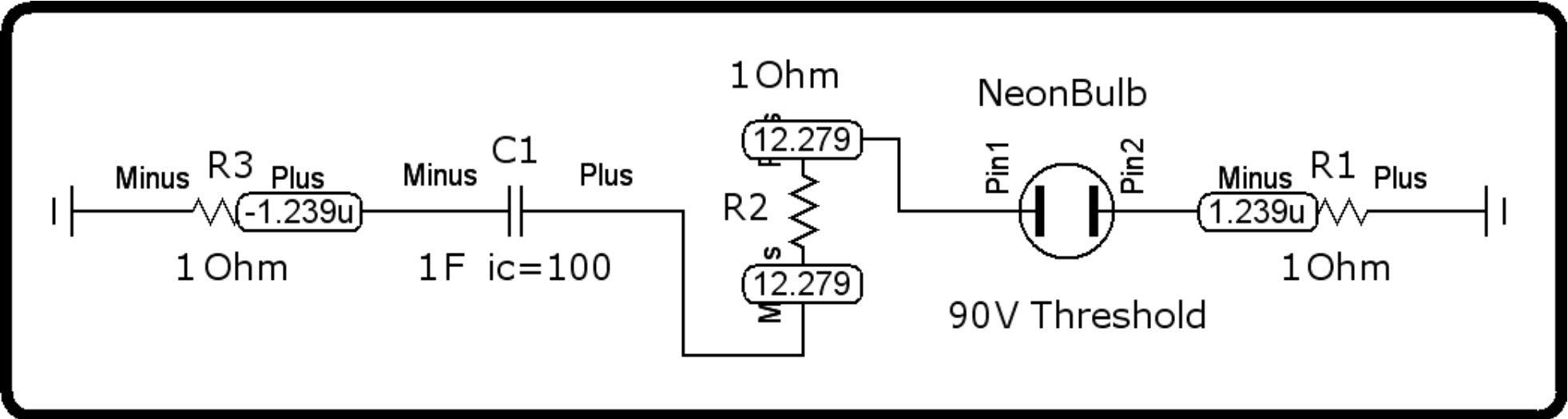

FIG. 50

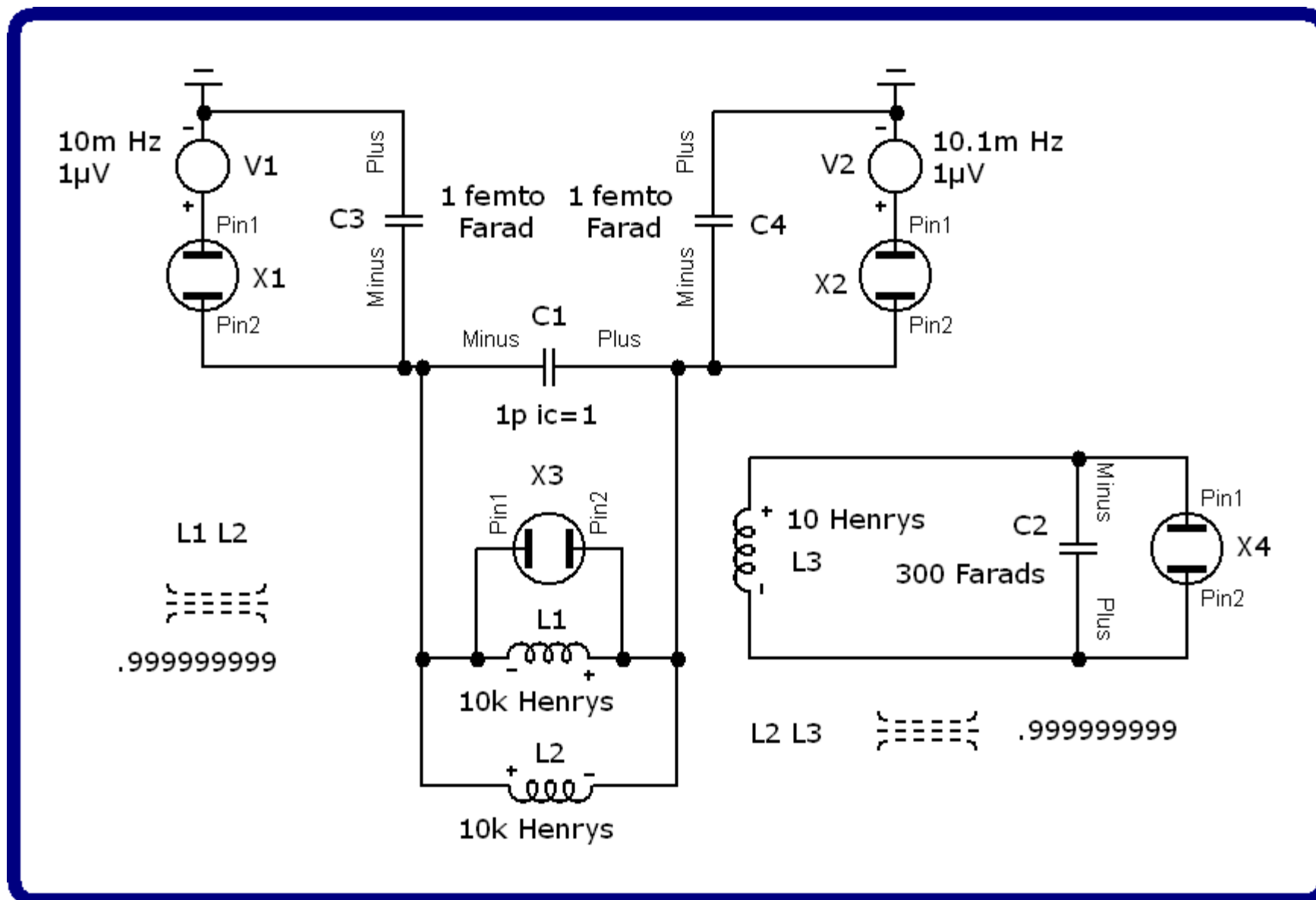

FIG. 51

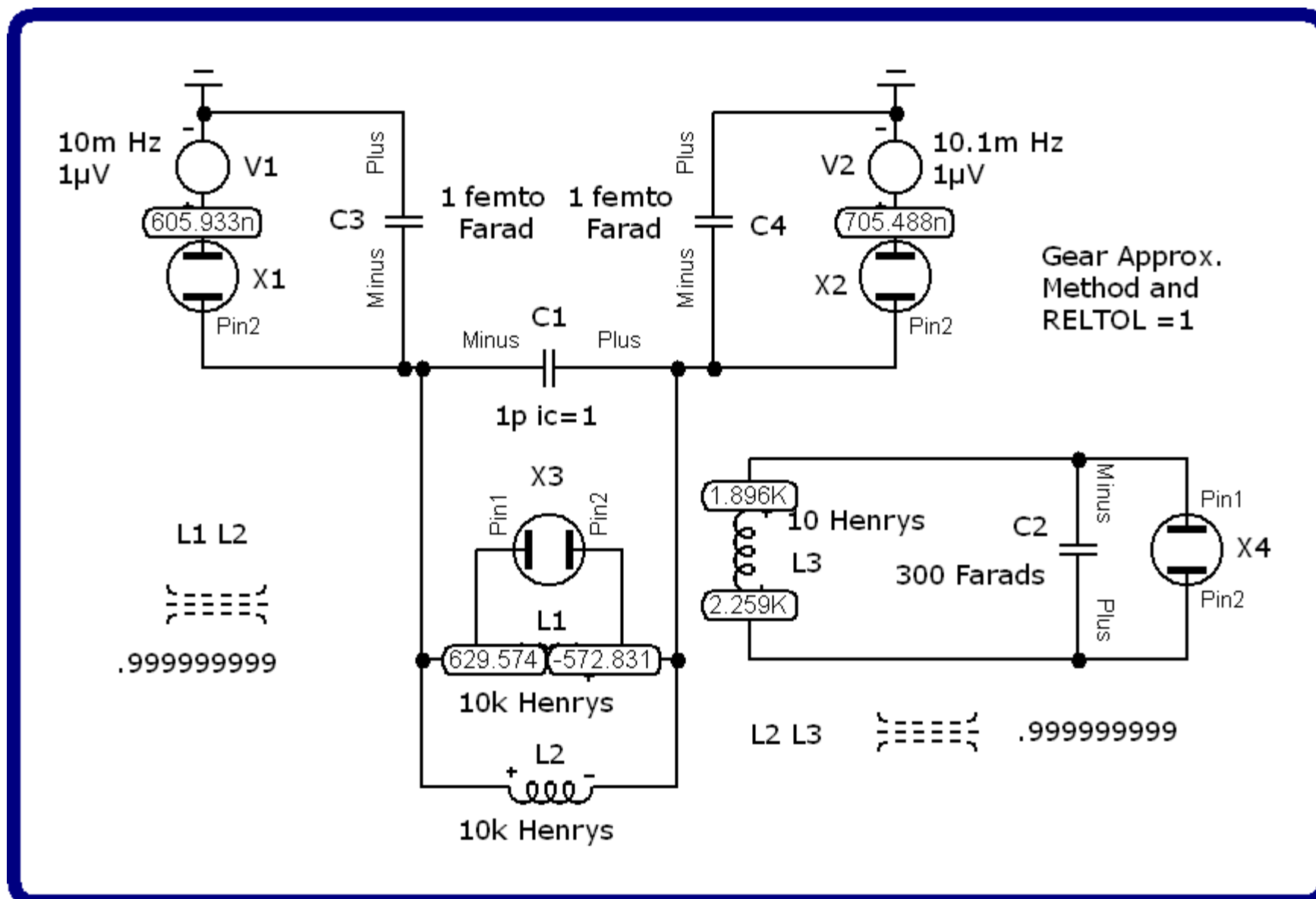
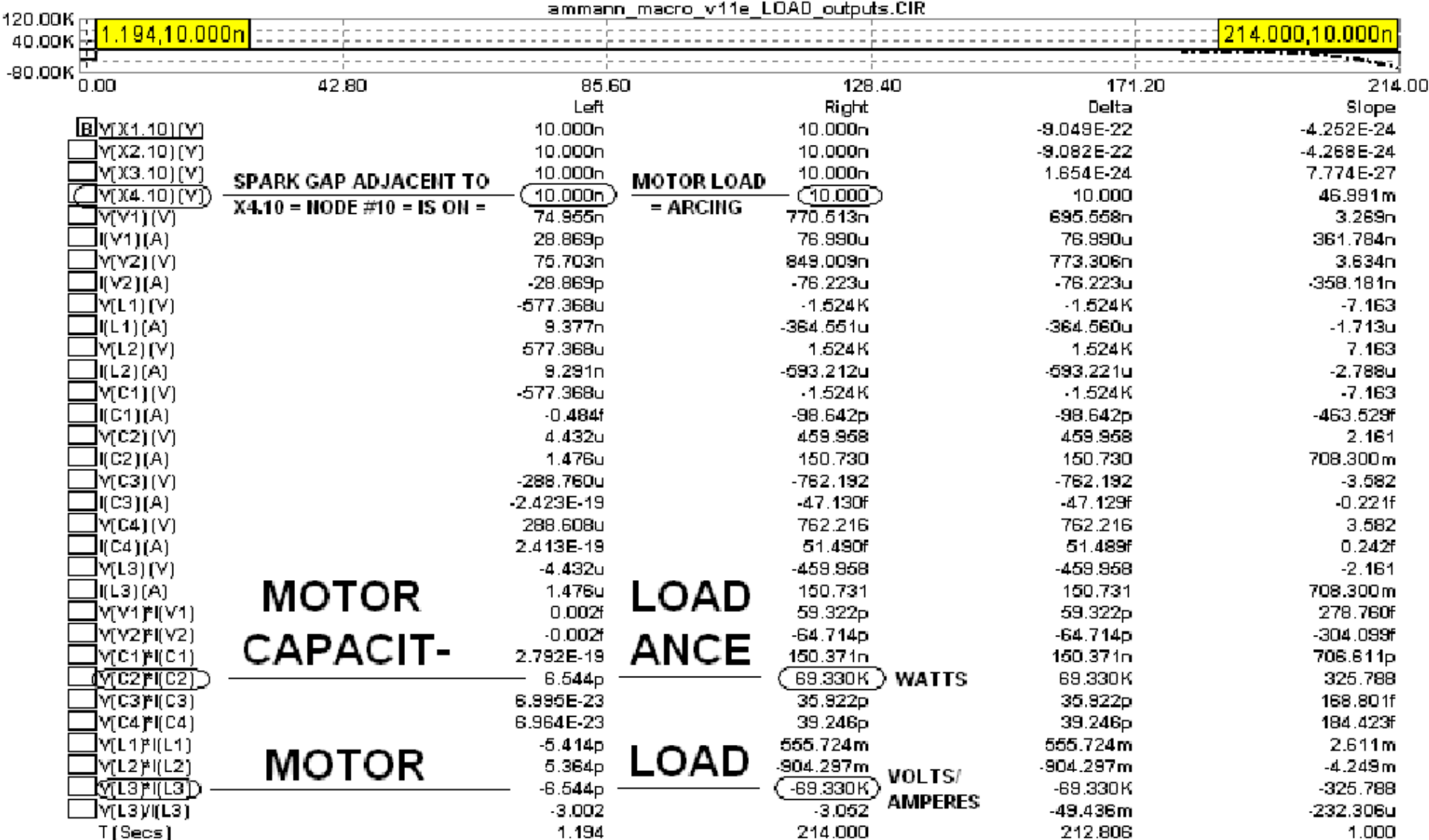

FIG. 52



**-69.33KVA = V(L3) × I(L3) = TARGET FOR AN ELECTRIC VEHICLE  
 { MOTOR COIL } = IN 214 SECONDS**

FIG. 53

ammann\_macro\_v11e\_X1\_outputs.CIR

	42.80	85.60	128.40	171.20	.00
90.00	881.604m,6.315E-39				214.000,9.036E-33
0					
		Left	Right	Delta	Slope
<input checked="" type="checkbox"/> V(X1.R1) I(X1.R1)	6.315E-39	9.036E-33	9.036E-33	4.240E-35	
<input type="checkbox"/> V(X1.R2) I(X1.R2)	0.005f	251.164u	251.164u	1.179u	
<input type="checkbox"/> V(X1.R3) I(X1.R3)	-1.721E-36	-158.731f	-158.731f	-0.745f	
<input type="checkbox"/> V(X1.R4) I(X1.R4)	6.159E-23	155.603n	155.603n	730.125p	
<input type="checkbox"/> V(X1.D1) I(X1.D1)	13.833f	180.335n	180.335n	846.172p	
<input type="checkbox"/> V(X1.D2) I(X1.D2)	13.828f	4.071u	4.071u	19.100n	
<input type="checkbox"/> V(X1.L1) I(X1.L1)	4.656E-36	1.694E-21	1.694E-21	7.947E-24	
<input type="checkbox"/> V(X1.C1) I(X1.C1)	4.220E-23	162.479p	162.479p	762.386f	
<input type="checkbox"/> V(X1.C2) I(X1.C2)	5.177E-20	135.994f	135.994f	0.638f	
<input type="checkbox"/> V(X1.V1) I(X1.V1)	0.000	0.000	0.000	0.000	
<input type="checkbox"/> V(X1.G1) I(X1.G1)	6.159E-21	15.560u	15.560u	73.013n	
<input type="checkbox"/> V(X1.I0) (V)	10.000n	10.000n	3.309E-24	1.553E-26	
<input type="checkbox"/> V(X1.R1) (V)	-0.004f	4.251f	4.255f	0.020f	
<input type="checkbox"/> I(X1.R1) (A)	-1.777E-21	0.002f	0.002f	9.982E-21	
<input type="checkbox"/> V(X1.R2) (V)	7.315u	50.116	50.116	235.157m	
<input type="checkbox"/> I(X1.R2) (A)	731.494f	5.012u	5.012u	23.516n	
<input type="checkbox"/> V(X1.R3) (V)	0.001f	-398.410n	-398.410n	-1.869n	
<input type="checkbox"/> I(X1.R3) (A)	-0.001f	398.410n	398.410n	1.869n	
<input type="checkbox"/> V(X1.R4) (V)	-784.793n	-39.447	-39.447	-185.092m	
<input type="checkbox"/> I(X1.R4) (A)	-0.078f	-3.945n	-3.945n	-18.509p	
<input type="checkbox"/> V(X1.D1) (V)	48.750m	452.634m	403.883m	1.895m	
<input type="checkbox"/> I(X1.D1) (A)	283.750f	398.412n	398.412n	1.869n	
<input type="checkbox"/> V(X1.D2) (V)	48.744m	-10.217	-10.266	-48.170m	
<input type="checkbox"/> I(X1.D2) (A)	283.690f	-398.412n	-398.412n	-1.869n	
<input type="checkbox"/> V(X1.L1) (V)	0.004f	-4.251f	-4.255f	-0.020f	
<input type="checkbox"/> I(X1.L1) (A)	0.001f	-398.410n	-398.410n	-1.869n	
<input type="checkbox"/> V(X1.C1) (V)	-7.315u	-50.116	-50.116	-235.157m	
<input type="checkbox"/> I(X1.C1) (A)	-0.006f	-3.242p	-3.242p	-15.212f	
<input type="checkbox"/> V(X1.C2) (V)	-6.530u	-10.670	-10.670	-50.065m	
<input type="checkbox"/> I(X1.C2) (A)	-7.928f	-12.748f	-4.818f	-0.023f	
<input type="checkbox"/> V(X1.V1) (V)	0.000	0.000	0.000	0.000	
<input type="checkbox"/> I(X1.V1) (A)	0.001f	-398.410n	-398.410n	-1.869n	
<input type="checkbox"/> V(X1.G1) (V)	-784.793n	-39.447	-39.447	-185.092m	
<input type="checkbox"/> I(X1.G1) (A)	-7.848f	-394.466n	-394.466n	-1.851n	
T (Secs)	881.604m	214.000	213.118	1.000	

FIG. 54

ammann\_macro\_v11e\_X2\_outputs.CIR

	428.000m,2.227E-34	42.80	85.60	128.40	171.20	214.000,9.258E-33	.00
			Left	Right	Delta		Slope
<input checked="" type="checkbox"/> V(X2.R1) I(X2.R1)			2.227E-34	9.258E-33	9.036E-33		4.231E-35
<input type="checkbox"/> V(X2.R2) I(X2.R2)			0.001f	251.164u	251.164u		1.176u
<input type="checkbox"/> V(X2.R3) I(X2.R3)			-3.417E-25	-158.677f	-158.677f		-0.743f
<input type="checkbox"/> V(X2.R4) I(X2.R4)			0.006f	155.550n	155.550n		728.325p
<input type="checkbox"/> V(X2.D1) I(X2.D1)			295.527p	9.249u	9.249u		43.307n
<input type="checkbox"/> V(X2.D2) I(X2.D2)			292.096p	180.436n	180.144n		843.481p
<input type="checkbox"/> V(X2.L1) I(X2.L1)			3.901E-28	1.714E-21	1.714E-21		8.026E-24
<input type="checkbox"/> V(X2.C1) I(X2.C1)			0.004f	162.478p	162.478p		760.766f
<input type="checkbox"/> V(X2.C2) I(X2.C2)			-0.495f	-1.129p	-1.129p		-5.286f
<input type="checkbox"/> V(X2.V1) I(X2.V1)			0.000	0.000	0.000		0.000
<input type="checkbox"/> V(X2.G1) I(X2.G1)			0.644f	15.555u	15.555u		72.833n
<input type="checkbox"/> V(X2.I0) (V)			10.000n	10.000n	0.009f		4.379E-20
<input type="checkbox"/> V(X2.R1) (V)			-0.667f	-4.303f	-3.636f		-0.017f
<input type="checkbox"/> I(X2.R1) (A)			-3.337E-19	-0.002f	-0.002f		-8.512E-21
<input type="checkbox"/> V(X2.R2) (V)			-3.325u	-50.116	-50.116		-234.657m
<input type="checkbox"/> I(X2.R2) (A)			-332.466f	-5.012u	-5.012u		-23.466n
<input type="checkbox"/> V(X2.R3) (V)			584.516f	398.342n	398.342n		1.865n
<input type="checkbox"/> I(X2.R3) (A)			-584.516f	-398.342n	-398.342n		-1.865n
<input type="checkbox"/> V(X2.R4) (V)			253.703u	39.440	39.440		184.666m
<input type="checkbox"/> I(X2.R4) (A)			25.370f	3.944n	3.944n		18.467p
<input type="checkbox"/> V(X2.D1) (V)			273.851m	-10.224	-10.498		-49.153m
<input type="checkbox"/> I(X2.D1) (A)			1.079n	-904.700n	-905.780n		-4.241n
<input type="checkbox"/> V(X2.D2) (V)			273.601m	452.629m	179.029m		838.258u
<input type="checkbox"/> I(X2.D2) (A)			1.068n	398.640n	397.572n		1.862n
<input type="checkbox"/> V(X2.L1) (V)			0.667f	4.303f	3.636f		0.017f
<input type="checkbox"/> I(X2.L1) (A)			584.515f	398.342n	398.342n		1.865n
<input type="checkbox"/> V(X2.C1) (V)			3.325u	50.116	50.116		234.657m
<input type="checkbox"/> I(X2.C1) (A)			1.168p	3.242p	2.074p		9.711f
<input type="checkbox"/> V(X2.C2) (V)			-250.379u	10.676	10.677		49.991m
<input type="checkbox"/> I(X2.C2) (A)			1.978p	-105.788f	-2.084p		-9.756f
<input type="checkbox"/> V(X2.V1) (V)			0.000	0.000	0.000		0.000
<input type="checkbox"/> I(X2.V1) (A)			584.516f	398.342n	398.342n		1.865n
<input type="checkbox"/> V(X2.G1) (V)			253.703u	39.440	39.440		184.666m
<input type="checkbox"/> I(X2.G1) (A)			2.537p	394.398n	394.396n		1.847n
T (Secs)			428.000m	214.000	213.572		1.000

FIG. 55

ammann\_macro\_v11e\_X3\_outputs.CIR

	42.80	85.60	128.40	171.20	.00
	856.000m,3.587E-46			214.000,1.616E-30	
		Left	Right	Delta	Slope
<input checked="" type="checkbox"/> V(X3.R1) I(X3.R1)	3.587E-46		1.616E-30	1.616E-30	7.580E-33
<input type="checkbox"/> V(X3.R2) I(X3.R2)	3.024E-21		90.284u	90.284u	423.583n
<input type="checkbox"/> V(X3.R3) I(X3.R3)	-2.015E-39		-38.355f	-38.355f	-0.180f
<input type="checkbox"/> V(X3.R4) I(X3.R4)	5.773E-31		37.599n	37.599n	176.404p
<input type="checkbox"/> V(X3.D1) I(X3.D1)	14.416f		171.823n	171.823n	806.134p
<input type="checkbox"/> V(X3.D2) I(X3.D2)	14.416f		9.017u	9.017u	42.305n
<input type="checkbox"/> V(X3.L1) I(X3.L1)	3.803E-41		-1.113E-20	-1.113E-20	-5.223E-23
<input type="checkbox"/> V(X3.C1) I(X3.C1)	4.710E-26		58.409p	58.409p	274.035f
<input type="checkbox"/> V(X3.C2) I(X3.C2)	1.413E-25		-6.150p	-6.150p	-28.854f
<input type="checkbox"/> V(X3.V1) I(X3.V1)	0.000		0.000	0.000	0.000
<input type="checkbox"/> V(X3.G1) I(X3.G1)	5.773E-29		3.760u	3.760u	17.640n
<input type="checkbox"/> V(X3.10) (V)	10.000n		10.000n	0.002f	1.032E-20
<input type="checkbox"/> V(X3.R1) (V)	-8.470E-22		-56.843f	-56.843f	-0.267f
<input type="checkbox"/> I(X3.R1) (A)	-4.235E-25		-0.028f	-0.028f	-1.333E-19
<input type="checkbox"/> V(X3.R2) (V)	173.891n		30.047	30.047	140.972m
<input type="checkbox"/> I(X3.R2) (A)	17.389f		3.005u	3.005u	14.097n
<input type="checkbox"/> V(X3.R3) (V)	4.489E-20		-195.845n	-195.845n	-918.840p
<input type="checkbox"/> I(X3.R3) (A)	-4.489E-20		195.845n	195.845n	918.840p
<input type="checkbox"/> V(X3.R4) (V)	-75.978p		-19.391	-19.391	-90.974m
<input type="checkbox"/> I(X3.R4) (A)	-7.598E-21		-1.939n	-1.939n	-9.097p
<input type="checkbox"/> V(X3.D1) (V)	49.553m		439.245m	389.692m	1.828m
<input type="checkbox"/> I(X3.D1) (A)	290.917f		391.177n	391.177n	1.835n
<input type="checkbox"/> V(X3.D2) (V)	49.553m		-10.218	-10.267	-48.170m
<input type="checkbox"/> I(X3.D2) (A)	290.915f		-882.500n	-882.500n	-4.140n
<input type="checkbox"/> V(X3.L1) (V)	8.470E-22		56.843f	56.843f	0.267f
<input type="checkbox"/> I(X3.L1) (A)	4.489E-20		-195.845n	-195.845n	-918.840p
<input type="checkbox"/> V(X3.C1) (V)	-173.891n		-30.047	-30.047	-140.972m
<input type="checkbox"/> I(X3.C1) (A)	-2.709E-19		-1.944p	-1.944p	-9.120f
<input type="checkbox"/> V(X3.C2) (V)	-173.815n		-10.657	-10.657	-49.998m
<input type="checkbox"/> I(X3.C2) (A)	-0.001f		577.094f	577.095f	2.708f
<input type="checkbox"/> V(X3.V1) (V)	0.000		0.000	0.000	0.000
<input type="checkbox"/> I(X3.V1) (A)	4.489E-20		-195.845n	-195.845n	-918.840p
<input type="checkbox"/> V(X3.G1) (V)	-75.978p		-19.391	-19.391	-90.974m
<input type="checkbox"/> I(X3.G1) (A)	-0.001f		-193.906n	-193.906n	-909.740p
T (Secs)	856.000m		214.000	213.144	1.000

FIG. 56



ammann\_macro\_v11e\_X4\_outputs.CIR

	428.00	85.60	128.40	171.20	214.00
	428.000m,2.833E-41				214.000,1.010E-31
	42.80	85.60	128.40	171.20	214.00
		Left	Right	Delta	Slope
<input checked="" type="checkbox"/> V(X4.R1)I(X4.R1)		2.833E-41	1.010E-31	1.010E-31	4.728E-34
<input type="checkbox"/> V(X4.R2)I(X4.R2)		0.004f	1.005m	1.005m	4.704u
<input type="checkbox"/> V(X4.R3)I(X4.R3)		-5.369E-28	-817.499f	-817.499f	-3.828f
<input type="checkbox"/> V(X4.R4)I(X4.R4)		0.048f	801.391n	801.391n	3.752n
<input type="checkbox"/> V(X4.D1)I(X4.D1)		11.599p	9.257u	9.257u	43.344n
<input type="checkbox"/> V(X4.D2)I(X4.D2)		11.247p	428.417n	428.406n	2.006n
<input type="checkbox"/> V(X4.L1)I(X4.L1)		5.515E-33	1.285E-20	1.285E-20	6.016E-23
<input type="checkbox"/> V(X4.C1)I(X4.C1)		0.015f	649.916p	649.916p	3.043p
<input type="checkbox"/> V(X4.C2)I(X4.C2)		-4.826f	120.466f	125.292f	0.587f
<input type="checkbox"/> V(X4.V1)I(X4.V1)		0.000	0.000	0.000	0.000
<input type="checkbox"/> V(X4.G1)I(X4.G1)		4.840f	80.139u	80.139u	375.232n
<input type="checkbox"/> V(X4.I0)(V)		10.000n	10.000n	0.074f	3.482E-19
<input type="checkbox"/> V(X4.R1)(V)		-2.380E-19	-14.211f	-14.211f	-0.067f
<input type="checkbox"/> I(X4.R1)(A)		-1.190E-22	-0.007f	-0.007f	-3.327E-20
<input type="checkbox"/> V(X4.R2)(V)		-6.611u	-100.233	-100.233	-469.315m
<input type="checkbox"/> I(X4.R2)(A)		-661.148f	-10.023u	-10.023u	-46.931n
<input type="checkbox"/> V(X4.R3)(V)		23.170f	904.156n	904.156n	4.233n
<input type="checkbox"/> I(X4.R3)(A)		-23.170f	-904.156n	-904.156n	-4.233n
<input type="checkbox"/> V(X4.R4)(V)		695.689u	89.520	89.520	419.155m
<input type="checkbox"/> I(X4.R4)(A)		69.569f	8.952n	8.952n	41.915p
<input type="checkbox"/> V(X4.D1)(V)		198.294m	-10.238	-10.437	-48.867m
<input type="checkbox"/> I(X4.D1)(A)		58.492p	-904.157n	-904.216n	-4.234n
<input type="checkbox"/> V(X4.D2)(V)		197.605m	473.830m	276.225m	1.293m
<input type="checkbox"/> I(X4.D2)(A)		56.917p	904.157n	904.100n	4.233n
<input type="checkbox"/> V(X4.L1)(V)		2.380E-19	14.211f	14.211f	0.067f
<input type="checkbox"/> I(X4.L1)(A)		23.170f	904.156n	904.156n	4.233n
<input type="checkbox"/> V(X4.C1)(V)		6.611u	100.233	100.233	469.315m
<input type="checkbox"/> I(X4.C1)(A)		2.336p	6.484p	4.148p	19.421f
<input type="checkbox"/> V(X4.C2)(V)		-689.077u	10.712	10.713	50.160m
<input type="checkbox"/> I(X4.C2)(A)		7.003p	11.246f	-6.992p	-32.739f
<input type="checkbox"/> V(X4.V1)(V)		0.000	0.000	0.000	0.000
<input type="checkbox"/> I(X4.V1)(A)		23.170f	904.156n	904.156n	4.233n
<input type="checkbox"/> V(X4.G1)(V)		695.689u	89.520	89.520	419.155m
<input type="checkbox"/> I(X4.G1)(A)		6.957p	895.204n	895.197n	4.192n
T (Secs)	428.000m		214.000	213.572	1.000

FIG. 57

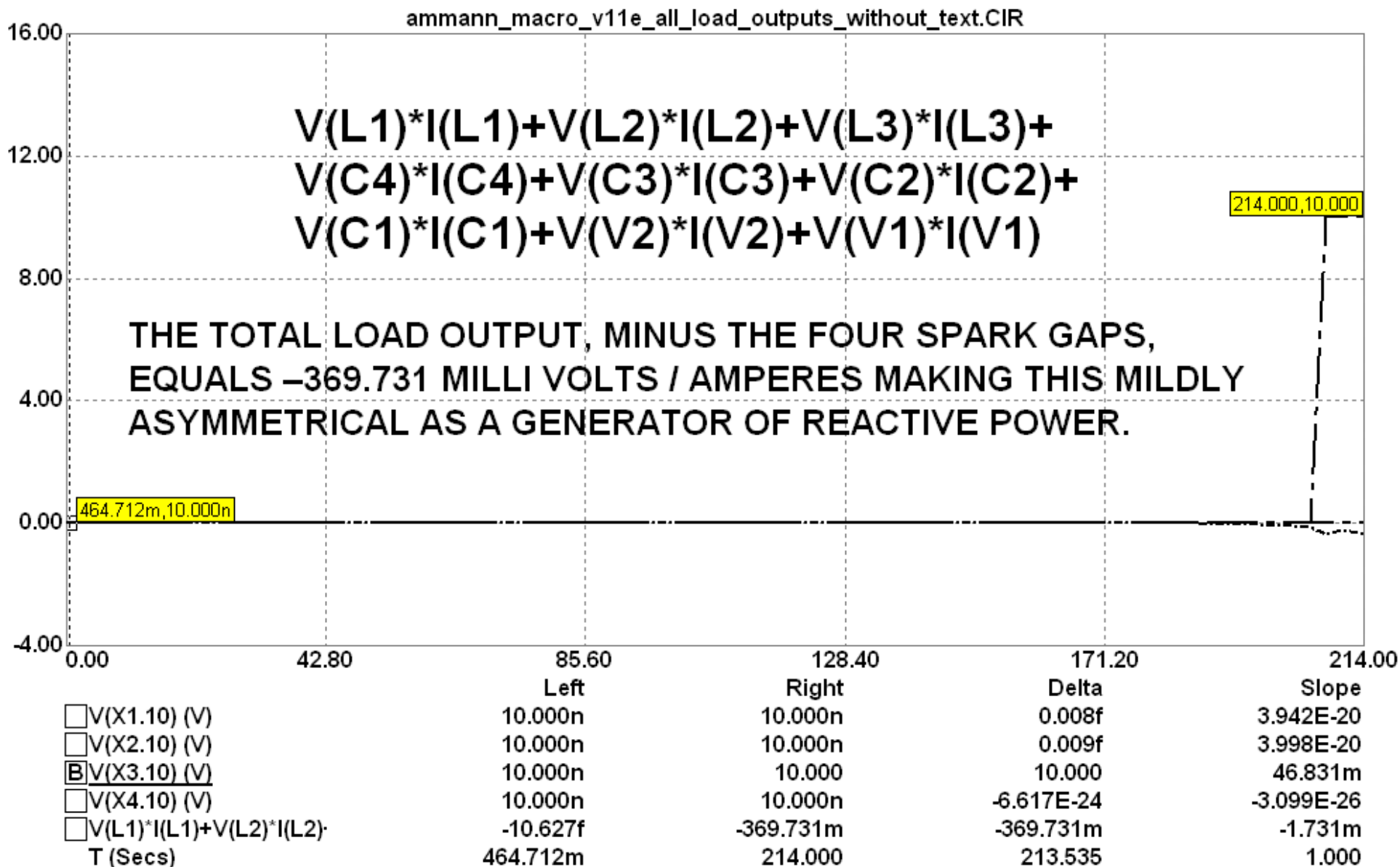
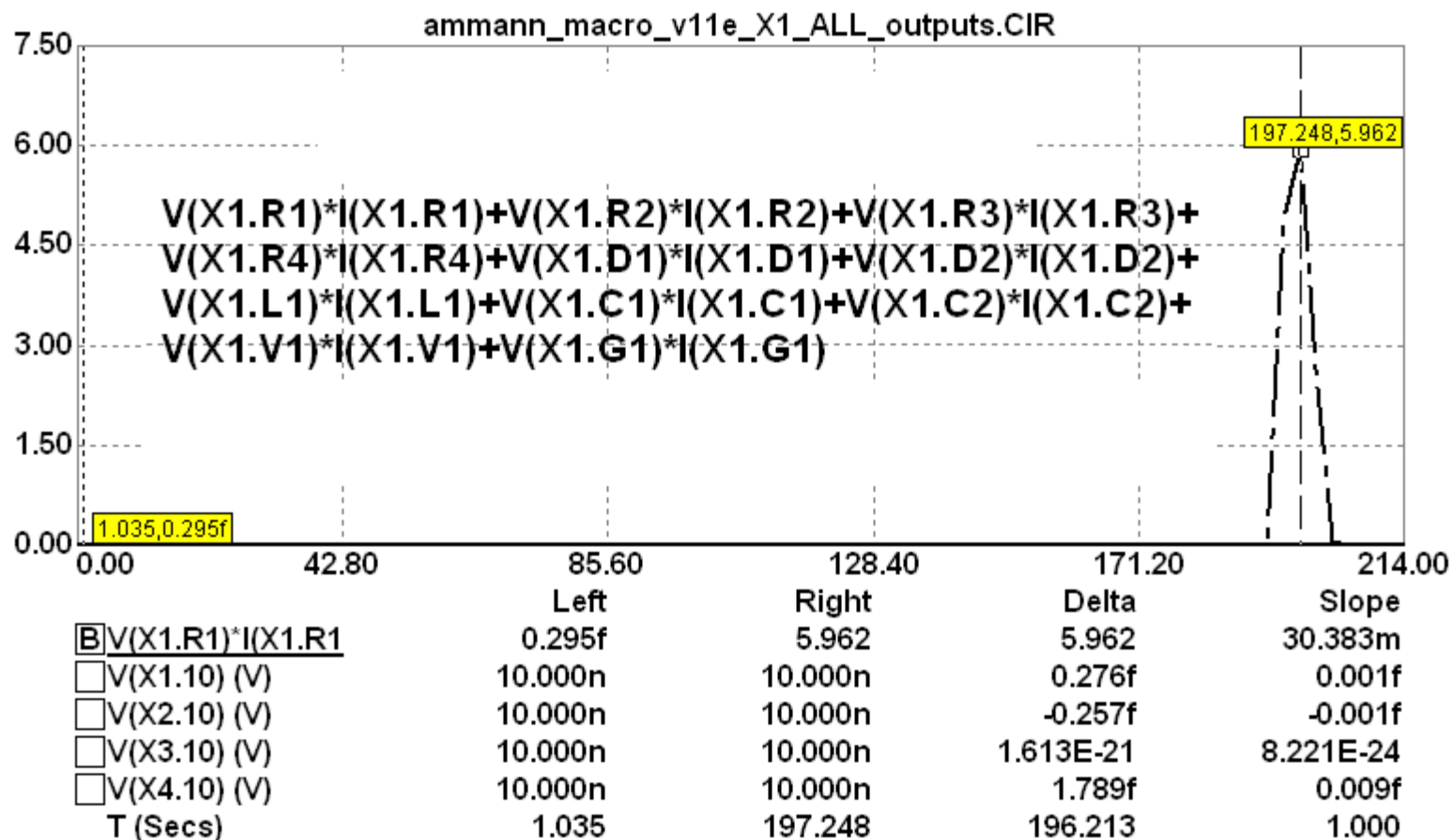
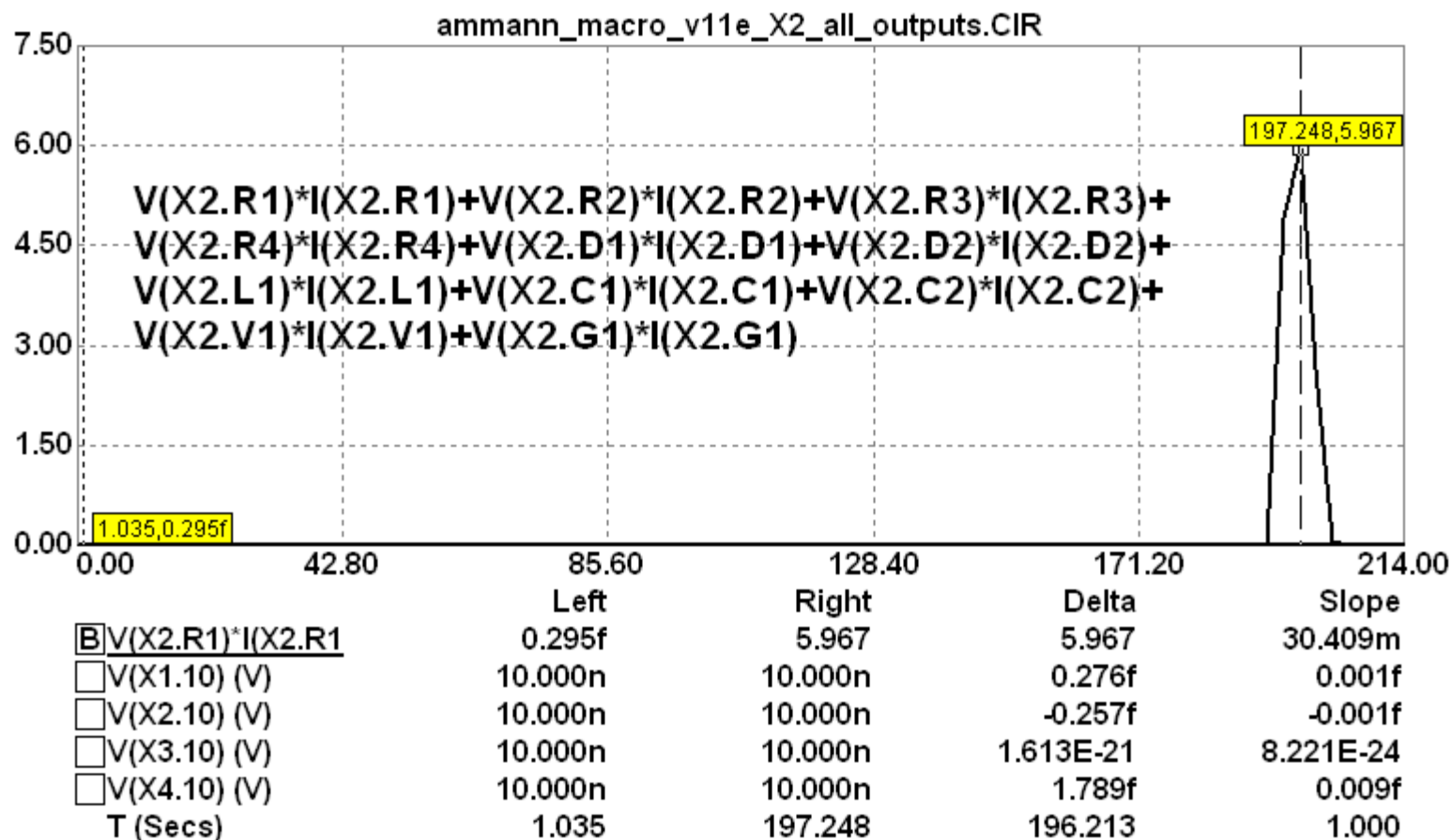

FIG. 58



**A spark gap of mild absorption / consumption spiking at 198 seconds and absorbing +6 watts of real power.**

**FIG. 59**



**A spark gap of mild absorption / consumption spiking at 197 seconds and absorbing +6 watts of real power.**

**FIG. 60**

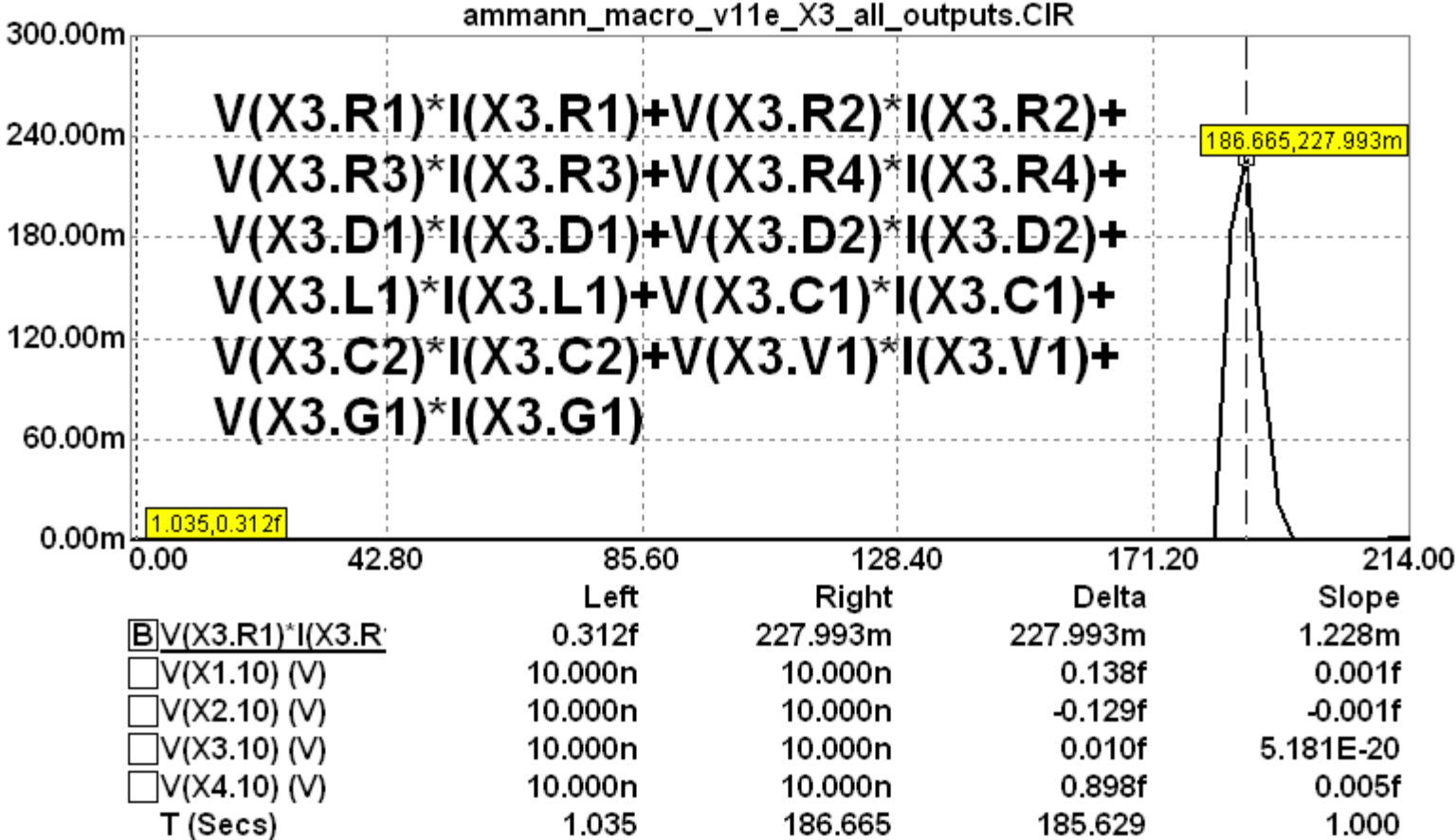

A spark gap of mild absorption / consumption spiking at nearly 187 seconds and absorbing +228 milli watts of real power.

FIG. 61

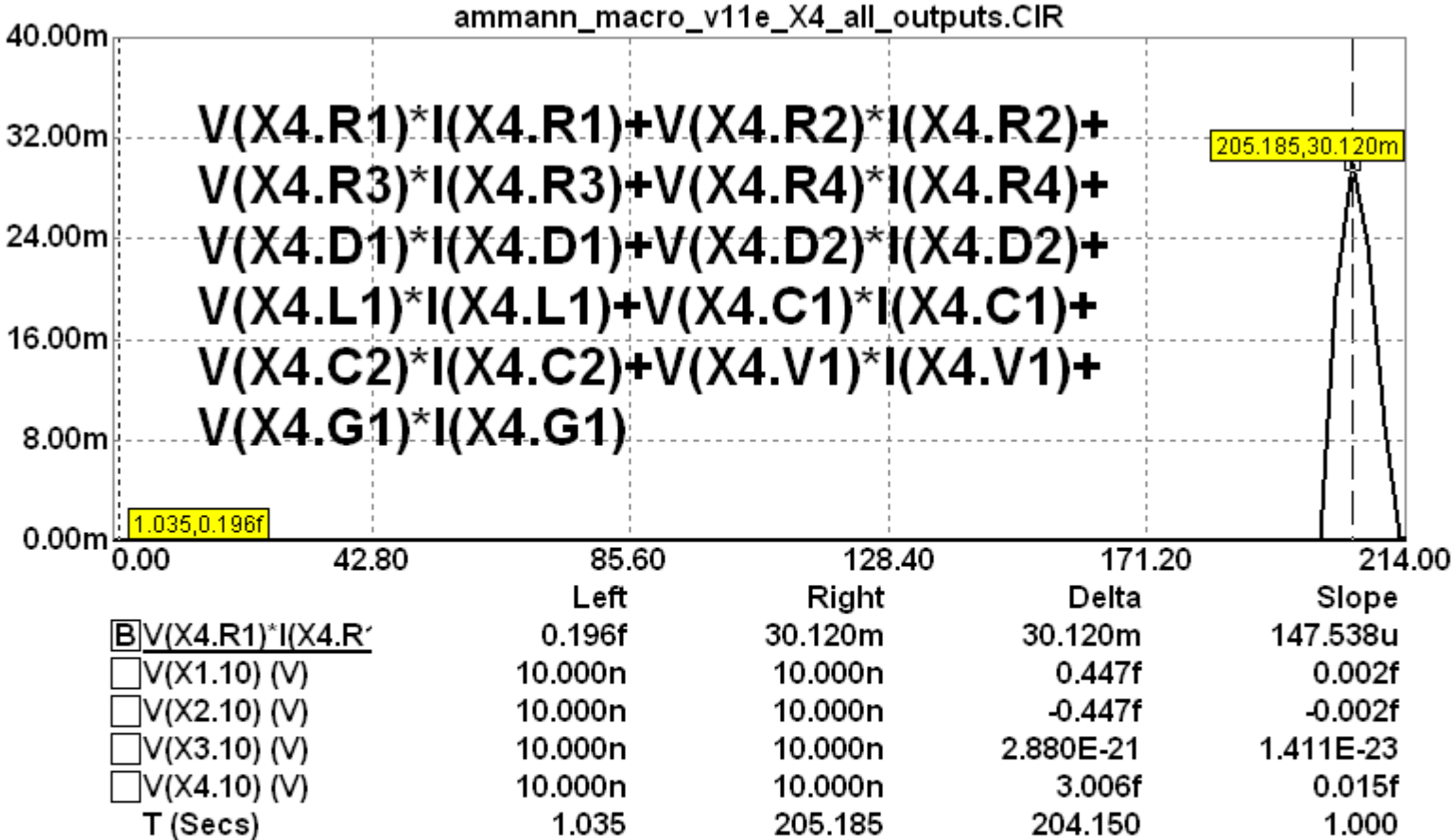

**A spark gap of mild absorption / consumption of real power spiking at 205 seconds and absorbing +30 milli watts.**

**FIG. 62**

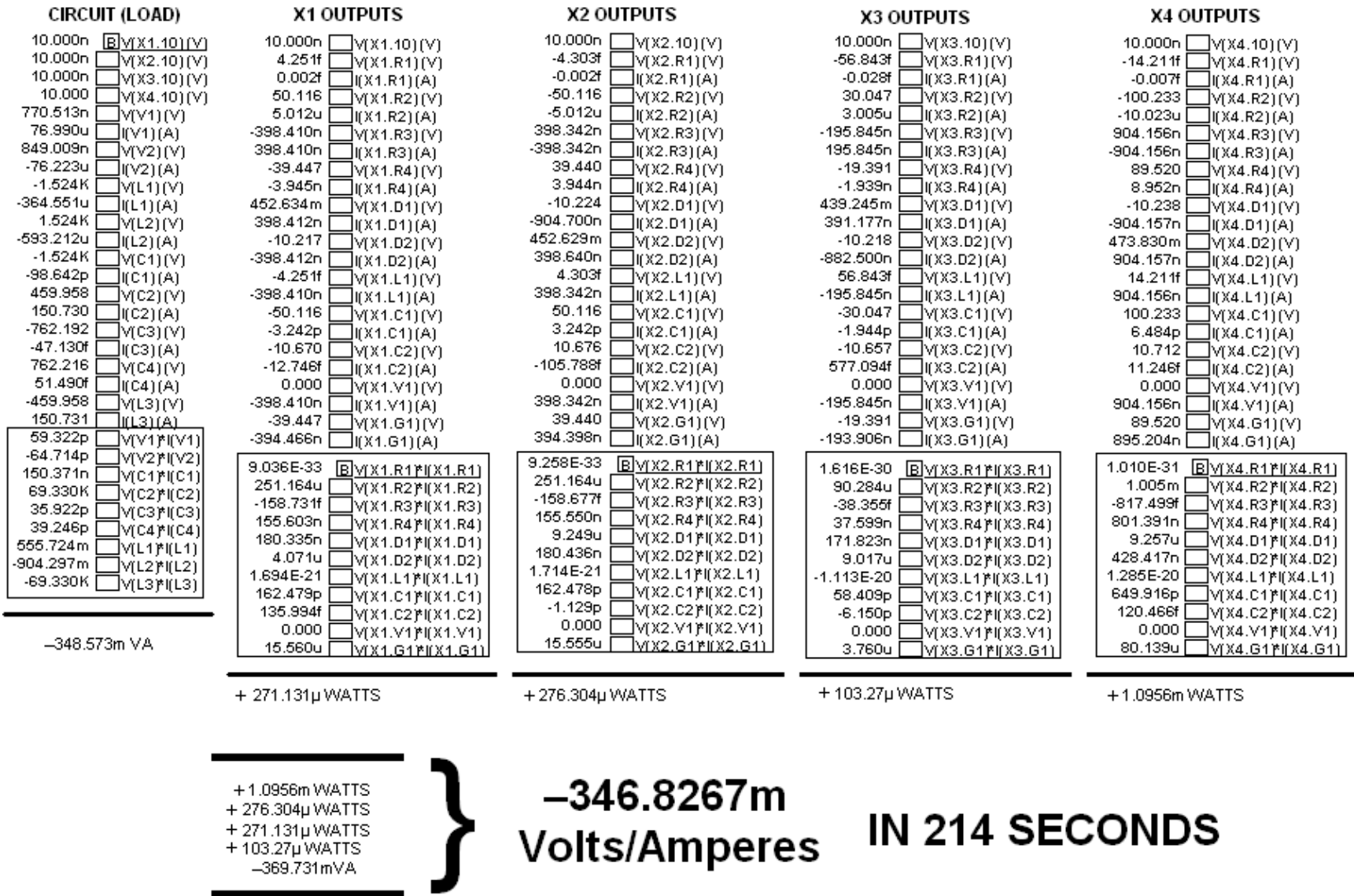

A SLIGHT ASYMMETRIC GAIN OVER LOSS. WHERE DID THIS EXCESS COME FROM? IT HAS LASTED TOO LONG AFTER THE INITIAL INPUT OF CAPACITOR, C1, WAS PRECHARGED WITH 1V.

FIG. 63

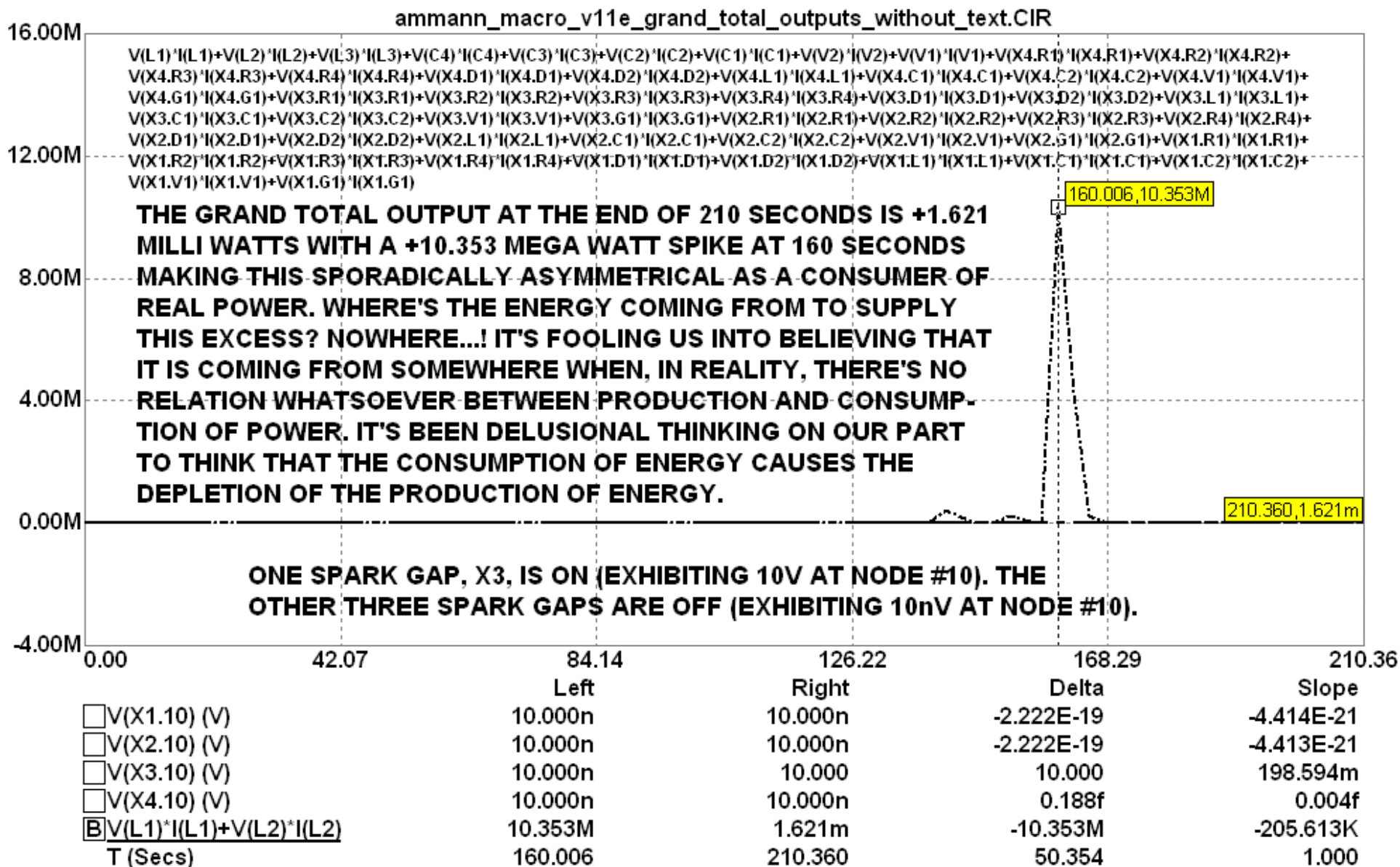
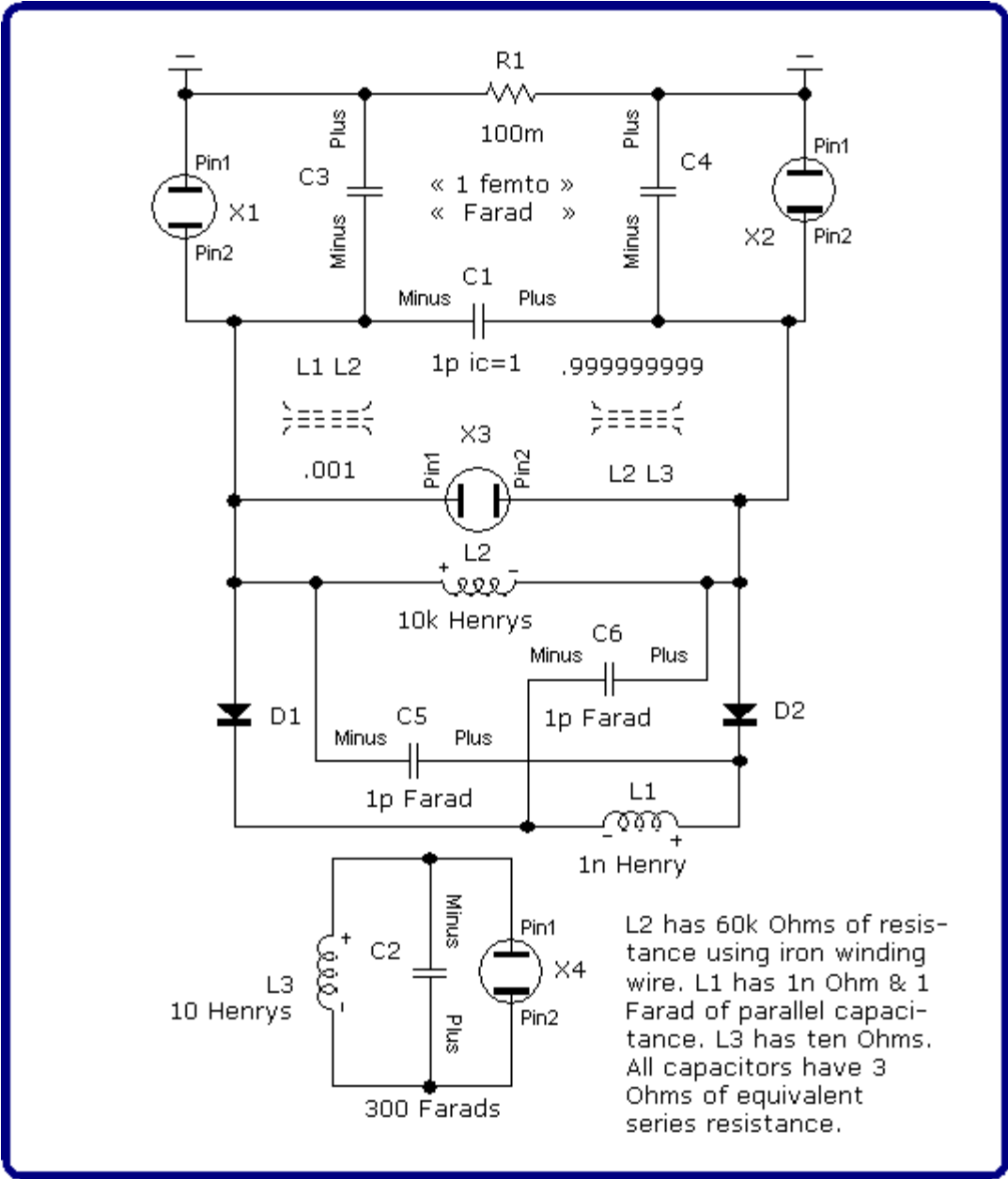

FIG. 64

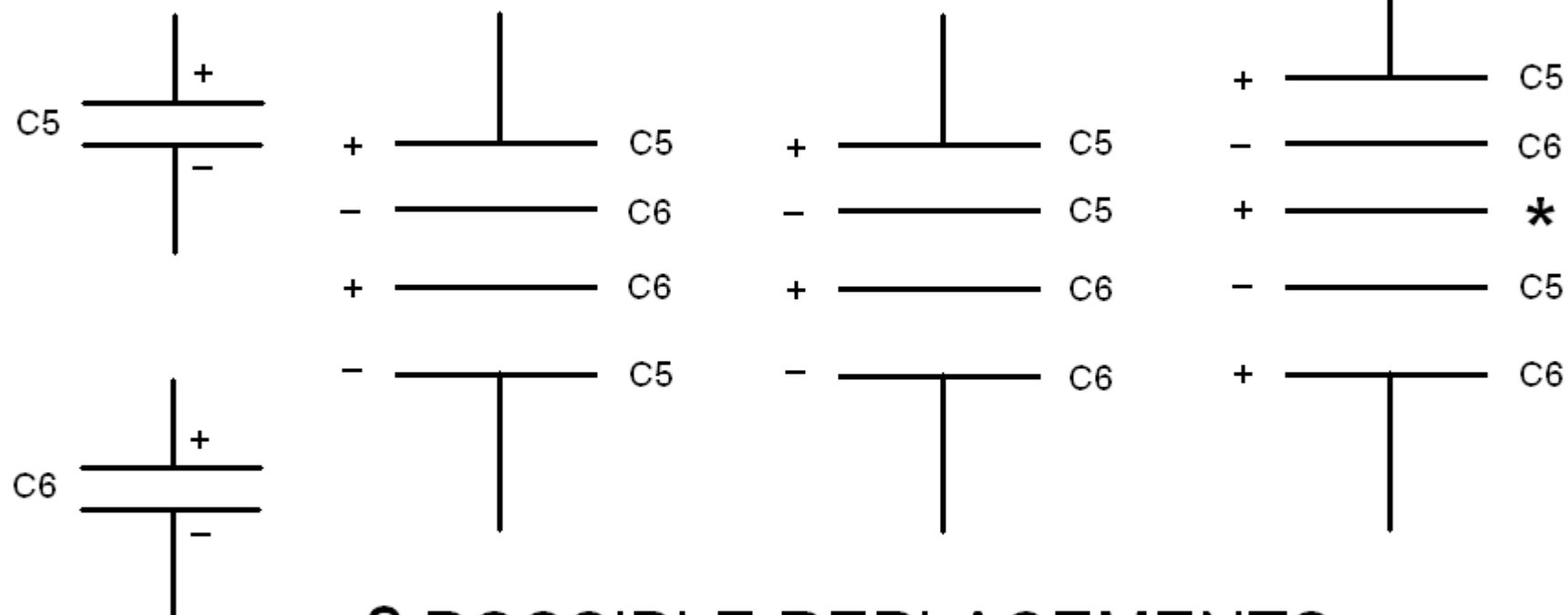

FIG. 65



Interleave two or more capacitors in order to increase the likelihood that they will charge, discharge or reflect at the same time.

\* A FLOATING PLATE NOT CONNECTED TO ANYTHING



3 POSSIBLE REPLACEMENTS  
FOR HAVING TWO SEPARATE  
CAPACITORS, C5 AND C6.

FIG. 66

FIG. 67

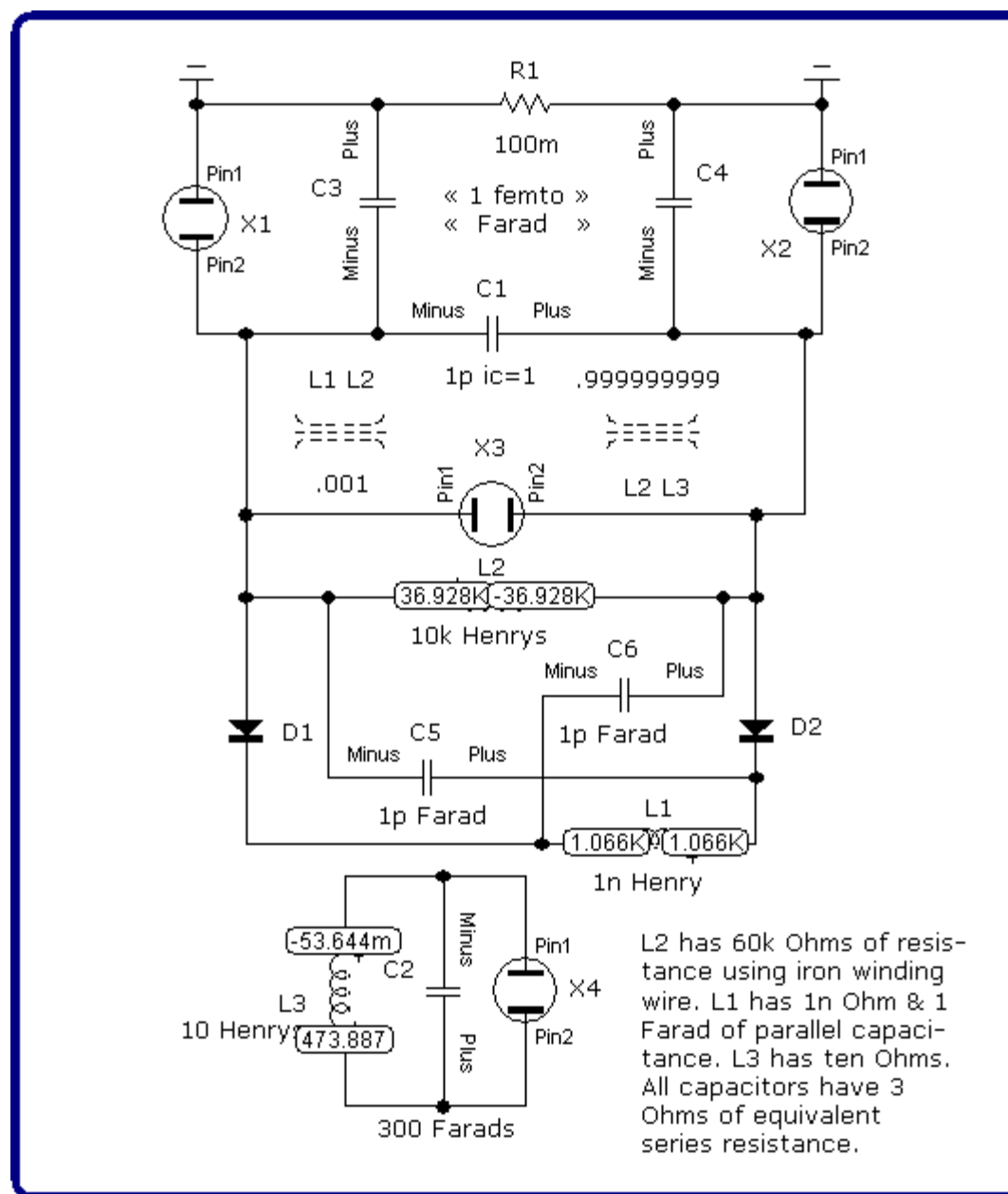

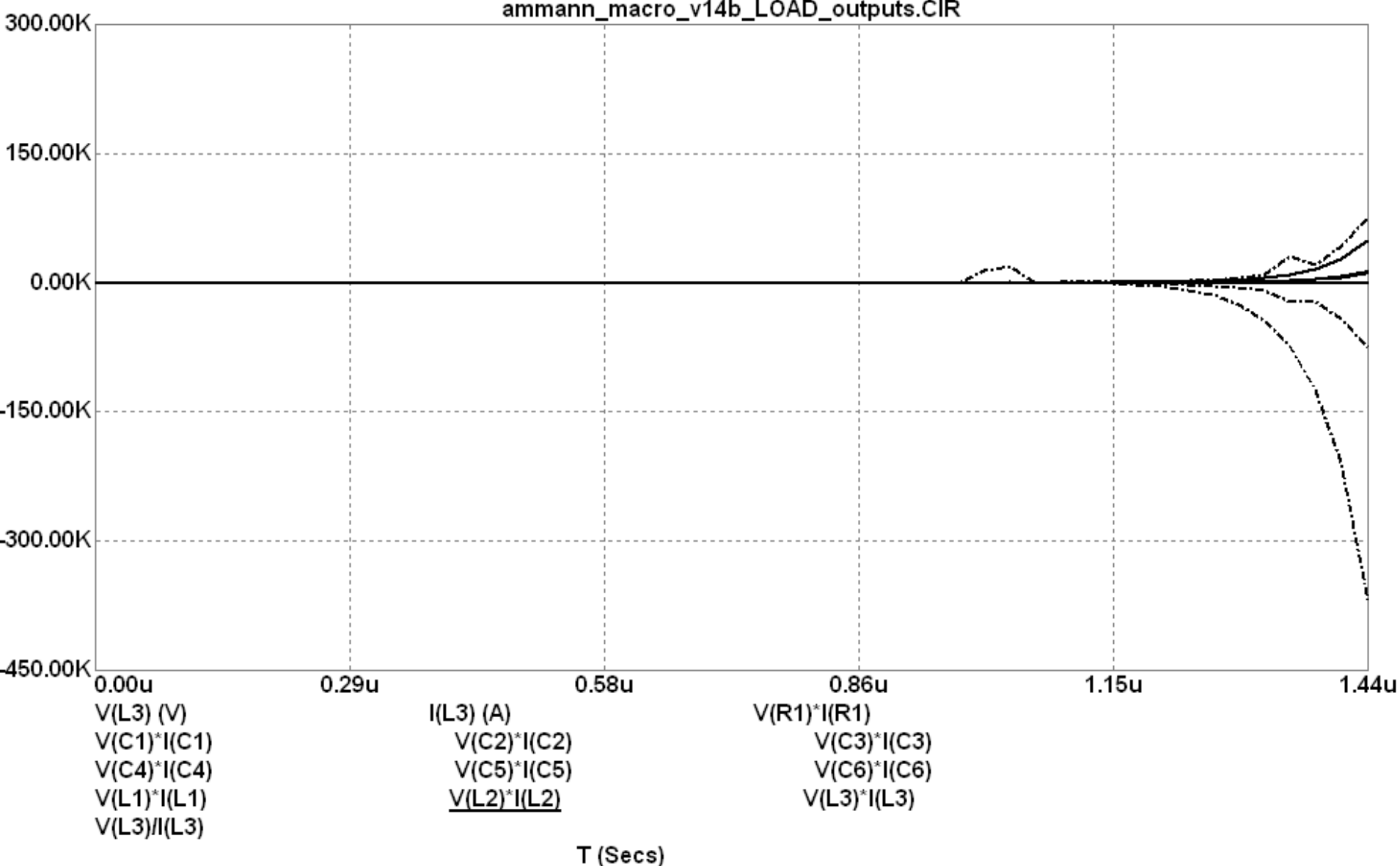

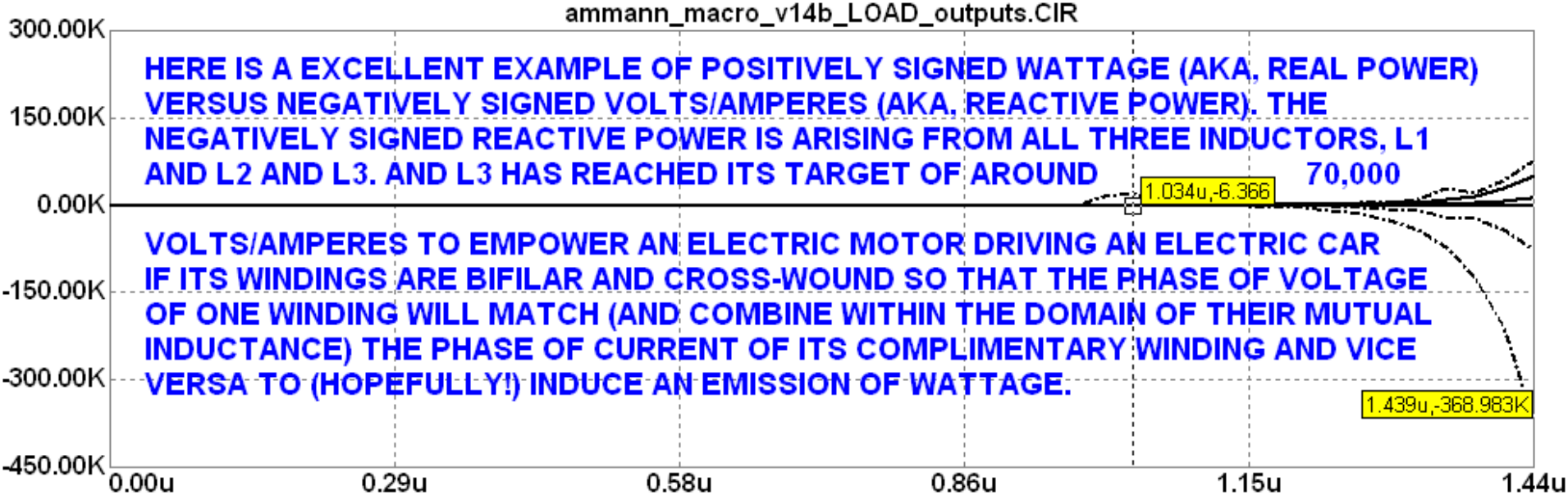

	Left	TIMES A POSI-	Right	TIVE AMPERAGE	Delta	Slope
<input type="checkbox"/> V(L3) (V)	242.113	Left	-473.941	PERES, AKA:	-716.053	-1.766G
<input type="checkbox"/> I(L3) (A)	4.989	Right	157.985		152.995	377.358M
<input type="checkbox"/> V(R1)*I(R1)	0.000		0.000	WATTS	0.000	0.000
<input type="checkbox"/> V(C1)*I(C1)	332.501m		49.084K	WATTS	49.084K	121.064G
<input type="checkbox"/> V(C2)*I(C2)	19.540K	REAL	74.873K	WATTS	55.334K	136.479G
<input type="checkbox"/> V(C3)*I(C3)	83.268u	POWER	12.271	WATTS	12.271	30.267M
<input type="checkbox"/> V(C4)*I(C4)	83.113u		12.272	WATTS	12.271	30.267M
<input type="checkbox"/> V(C5)*I(C5)	-4.302		11.917K	WATTS	11.921K	29.403G
<input type="checkbox"/> V(C6)*I(C6)	4.469		12.625K	WATTS	12.621K	31.129G
<input type="checkbox"/> V(L1)*I(L1)	-237.243n	REACTIVE	-604.321u	V.A.	-604.083u	-1.490K
<input checked="" type="checkbox"/> V(L2)*I(L2)	-6.366	POWER	-368.983K	V.A.	-368.976K	-910.068G
<input type="checkbox"/> V(L3)*I(L3)	1.208K		-74.875K	V.A.	-76.083K	-187.657G
<input type="checkbox"/> V(L3)/I(L3)	48.529		-3.000		-51.529	-127.093M
T (Secs)	1.034u		1.439u		405.438n	1.000

FIG. 69

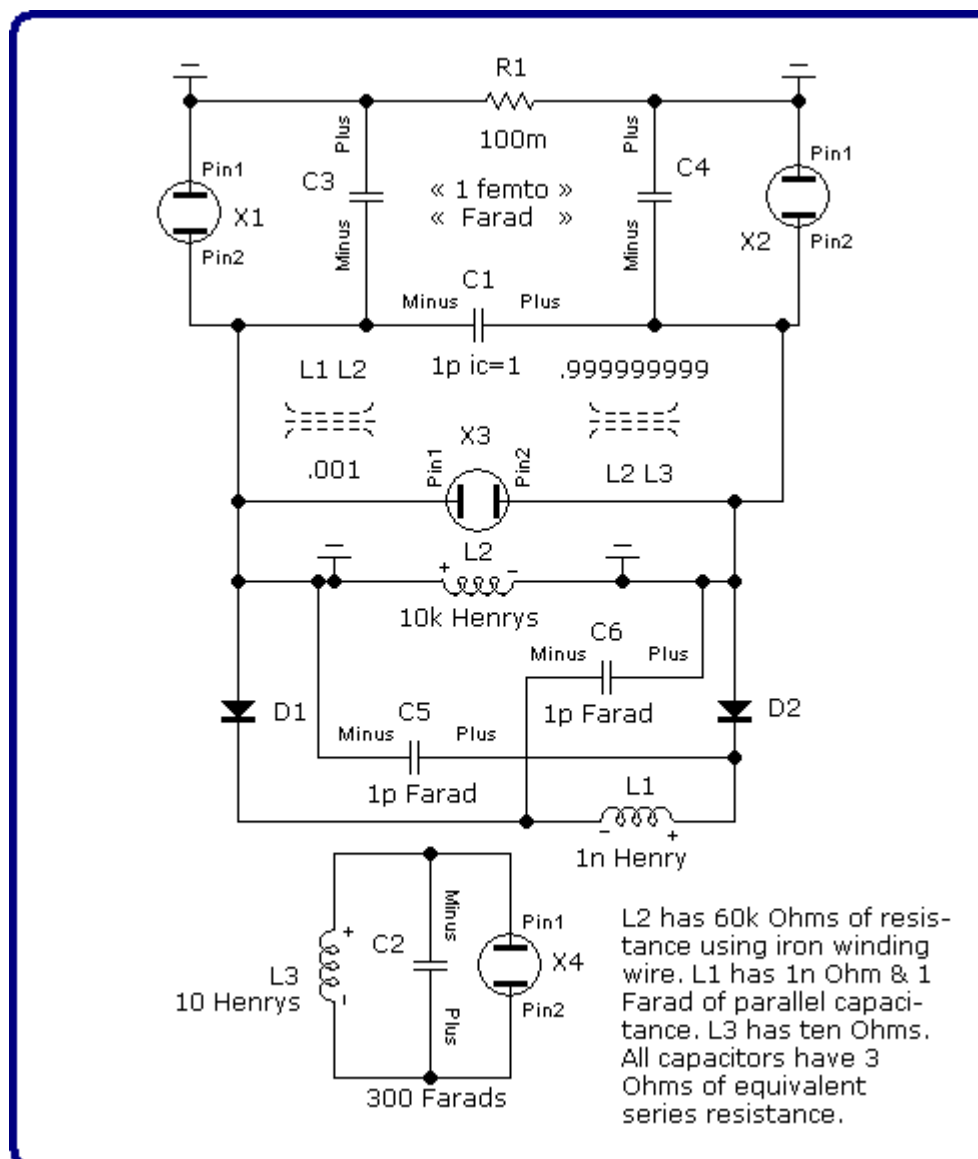

FIG. 70

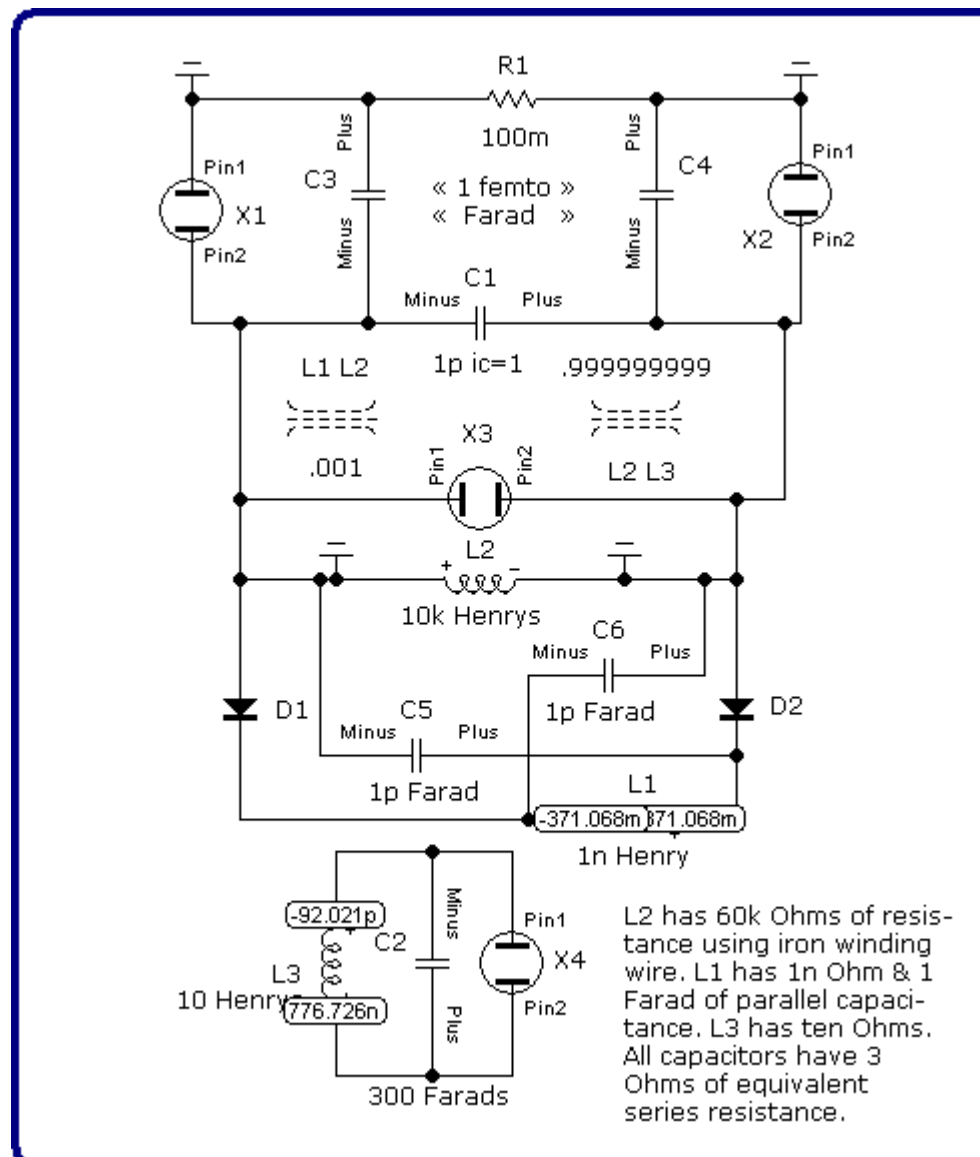

FIG. 71

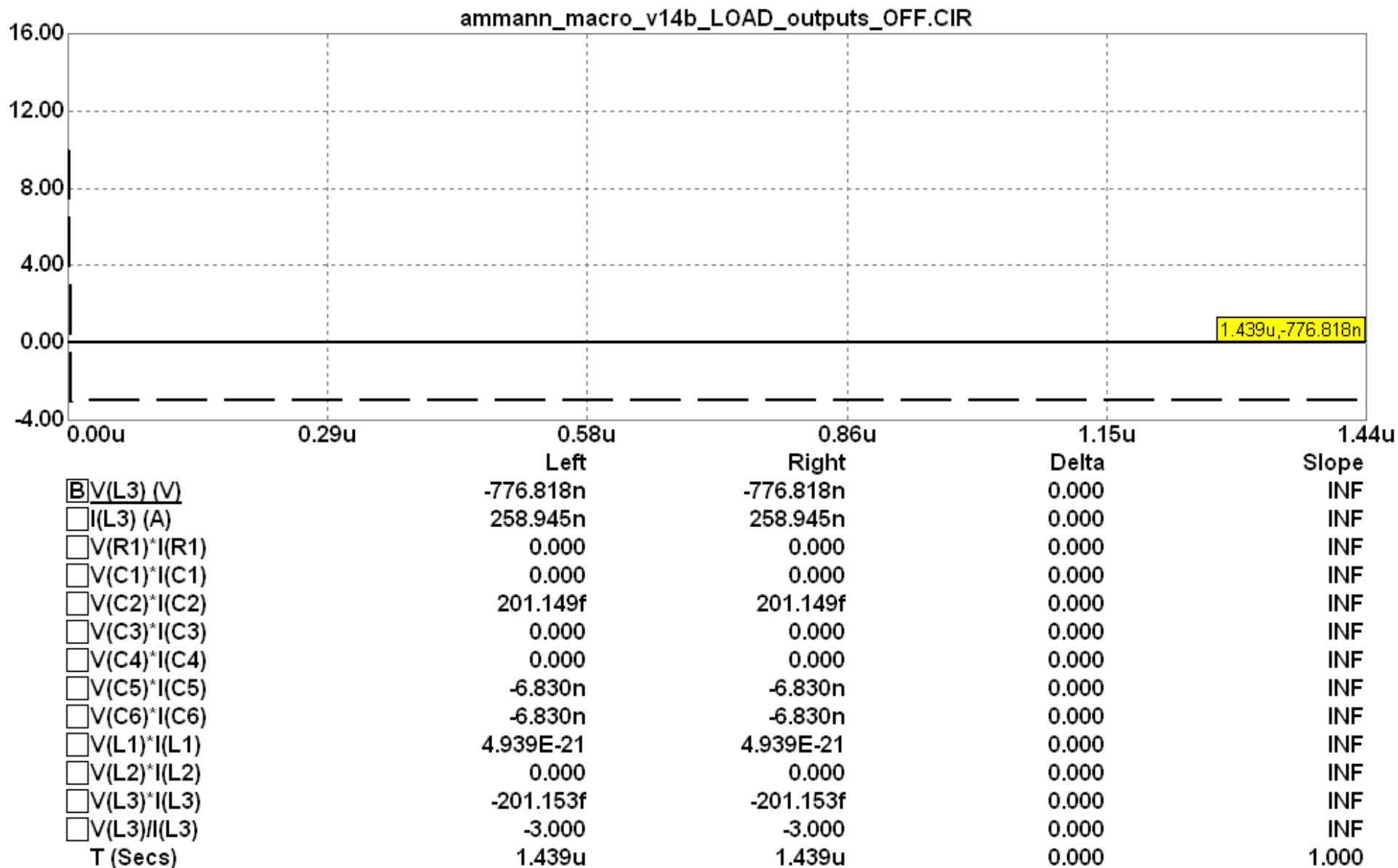
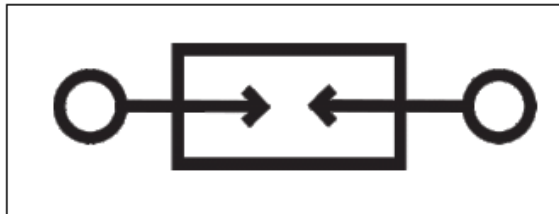
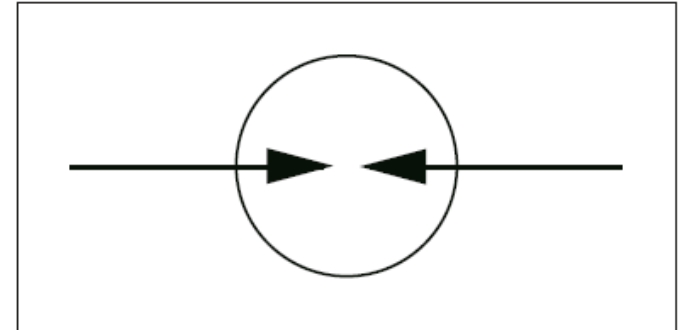
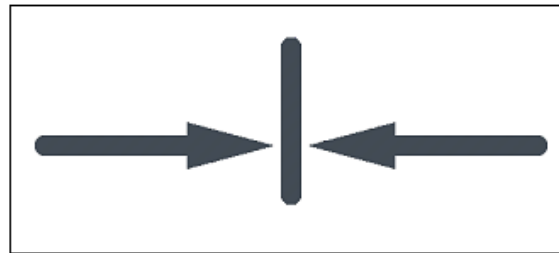
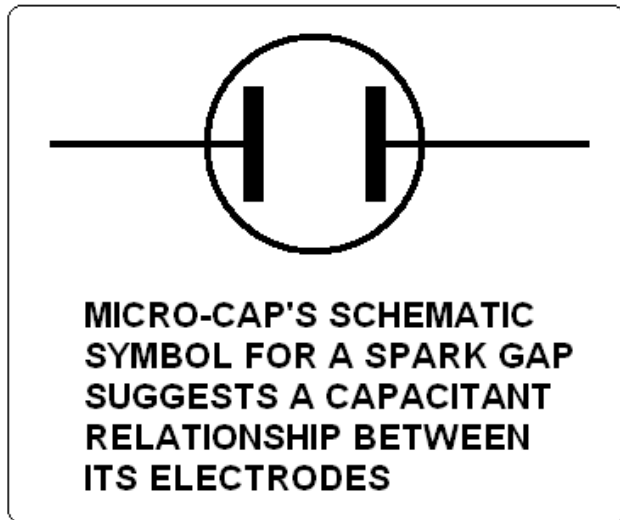

FIG. 72





COMMON ALTERNATIVE SCHEMATIC SYMBOLS FOR A SPARK GAP RESEMBLING TWO DIODES WHOSE CATHODES APPEAR TO BE FACING EACH OTHER

FIG. 73

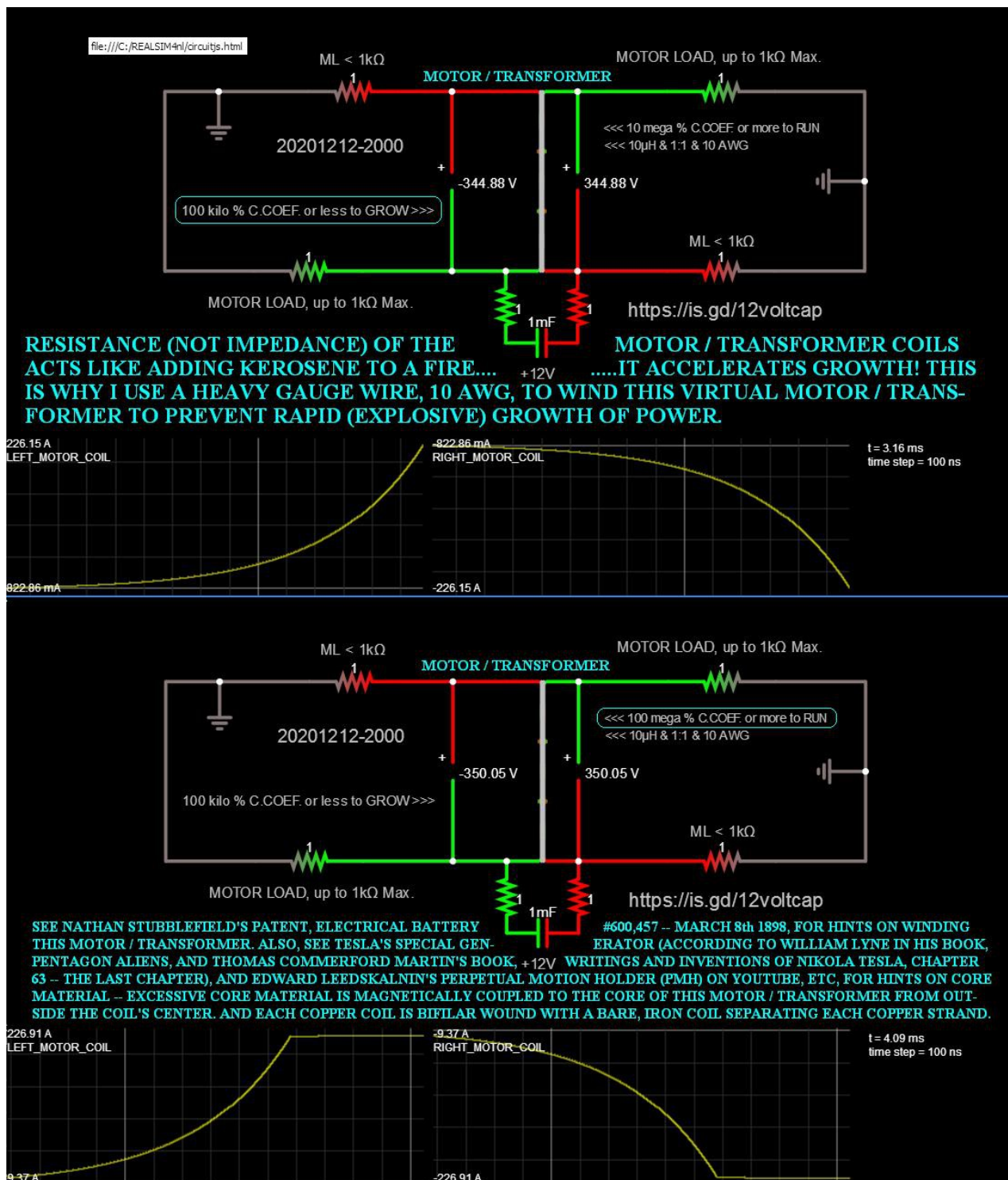

FIG. 74

This is as close as I can get to simulating Tesla's Special Generator for an EV!

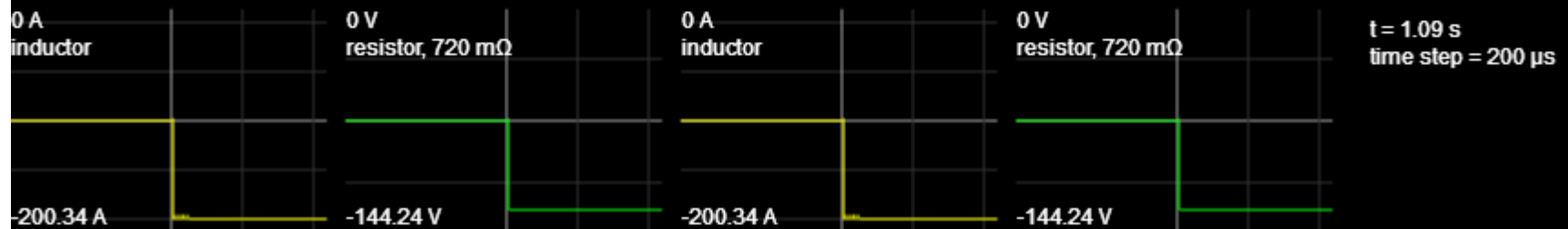
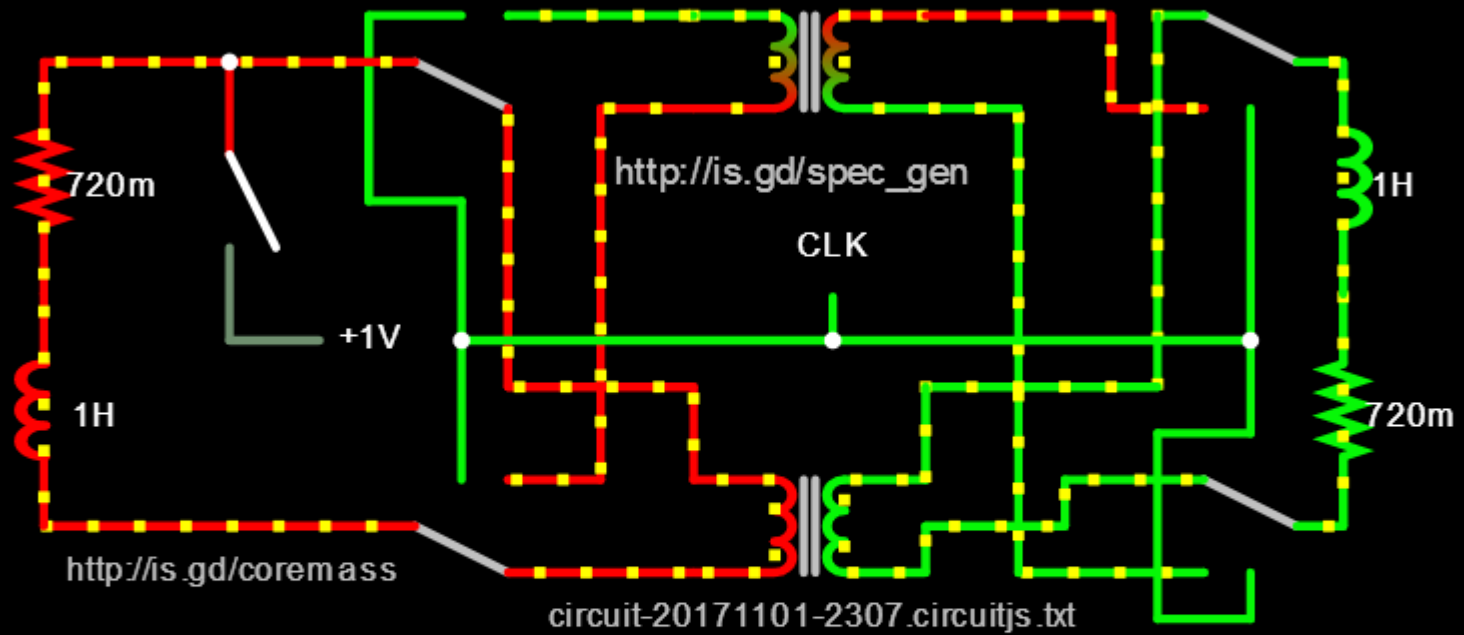

FIG. 75

Gradually add more Henrys to the top Transformer to slow its growth towards infinity until it has 100E Henrys equivalent to 100 Exa Henrys =  $100 \cdot 1e18$ .

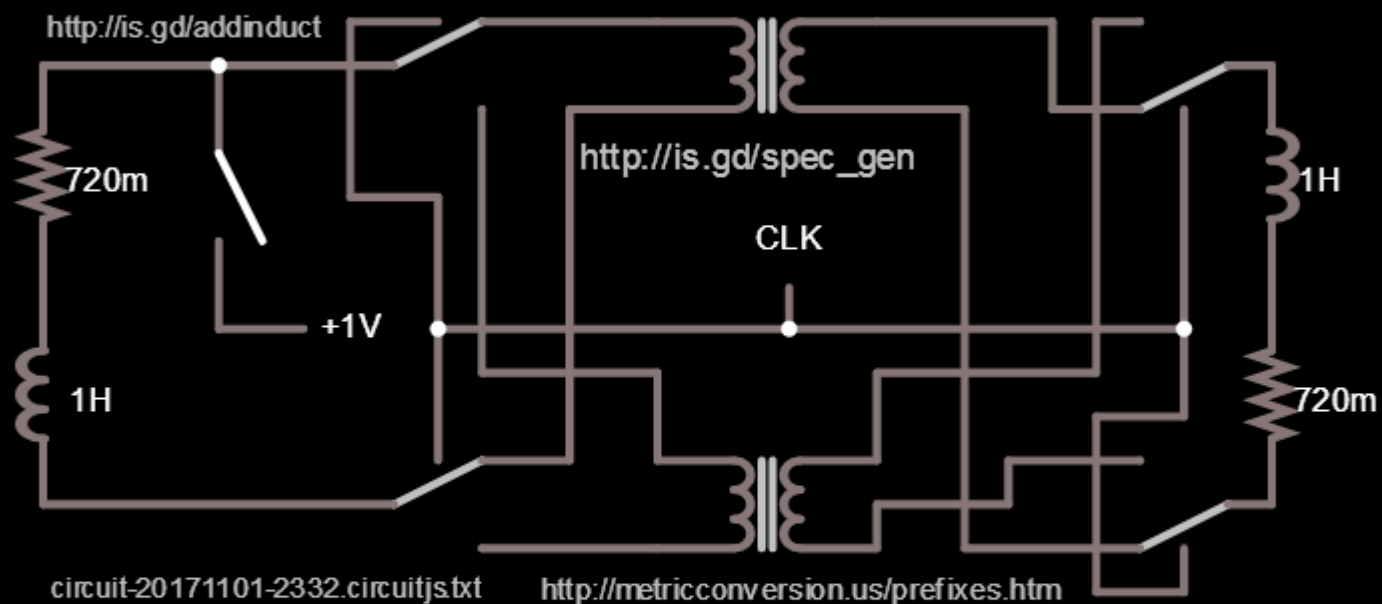
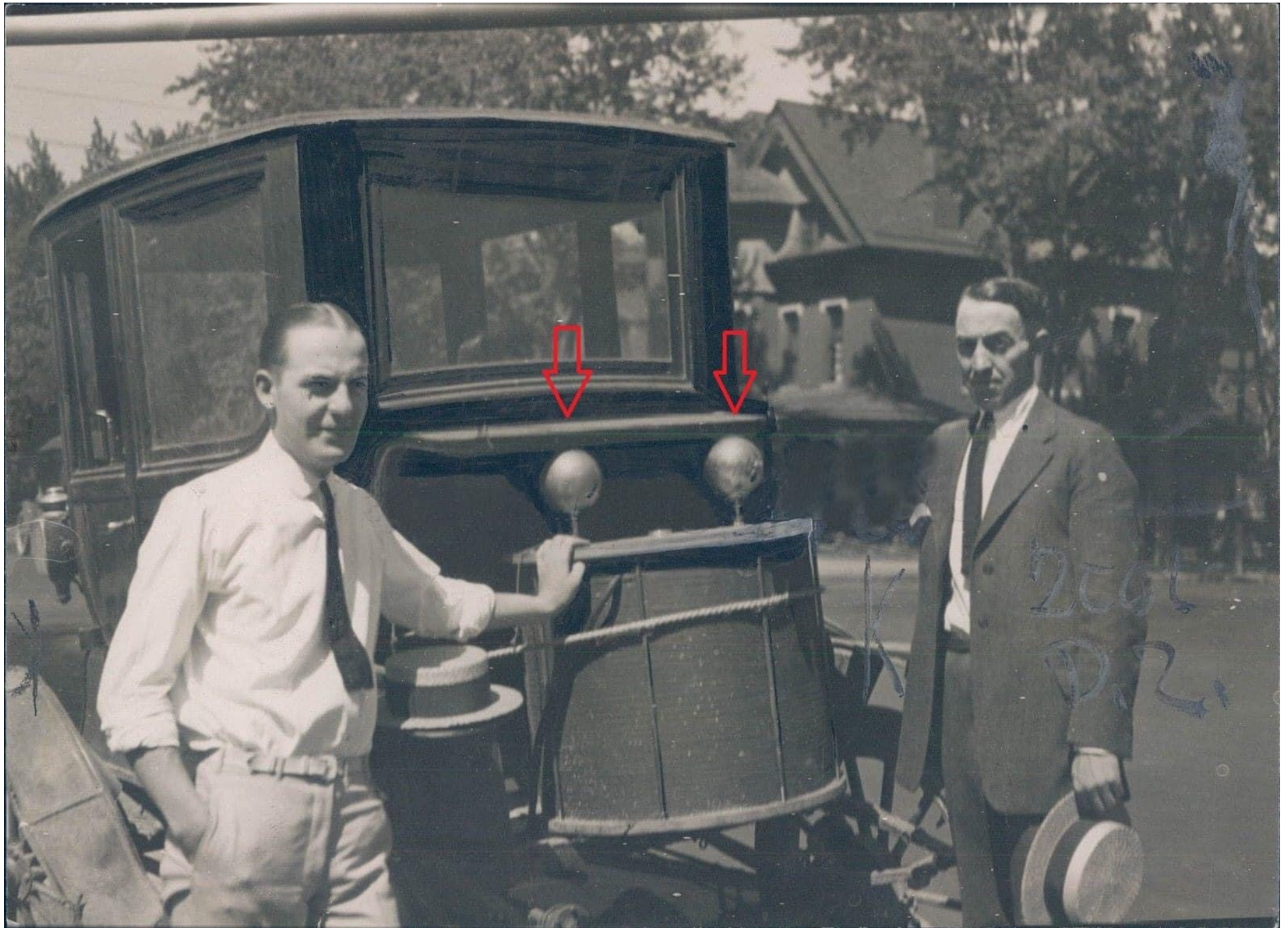

FIG. 76

FIG. 77

77/80



# SUBSTANTIAL CUT IN PIERCE-ARROW PRICE ANNOUNCED

A substantial reduction in the prices of its touring car models effective after September 1, and a reduction on the prices of its truck models, effective immediately, has been announced by George W. Mixer, president of the Pierce-Arrow Motor Car company.

The new price of the standard seven-passenger touring car is \$6,500 at the factory, the inclosed car prices being graded proportionately.

The new prices of its truck models are: \$4,950 for the five-ton size; \$4,350 for the 3½-ton and \$3,200 for the 2-ton.



## This Tire

# ELECTRICITY "TAKEN FROM AIR" DRIVES AUTOMOBILE



C. E. AMMANN AND HIS "ATMOSPHERIC GENERATOR" ATTACHED TO AN ELECTRIC AUTOMOBILE

DENVER, Colo., Aug. 28.—Demonstrations are being made on the streets of Denver of a new electric generator that is claimed by the inventors to take electricity from the air.

The inventors are J. E. Ammann of Denver, and his brother, C. E. Ammann of Spokane, Wash.

To demonstrate, the brothers borrowed an old electric auto, took out the batteries, and after roping their new "atmospheric generator" fast, they got in and rode off at high speed.

"There is nothing inside the drum that moves; the contents consists only of iron, wire and minerals," says C. E. Ammann.

"It can be used to drive any electrical apparatus and can be made in any size."

The brothers are closely guarding their secret, and even take their "brain-child" when it is not in use, to their room in the Argonaut hotel.

So far the brothers have not offered to sell their proposition.

Electrical men in Denver are waiting "to be shown," but they grant the thing works.

AUTO INSURANCE

balance bodies was the highlight of

# "New C

Buys a brand new s  
\$1,625.00 f. o. b. P  
automobile. The fa  
them to some other  
cost of re-shipment  
make special terms  
cars. There are onl

## NEW 1

The same m  
rather than re;sh  
excellent satisfact  
saving on a high-  
pay you to buy an

- \$2,500.00 truck cha
- \$2,700.00 truck cha
- curtains . . . . .
- \$3,000.00 truck cha
- open express bod

All of the al  
This offer w  
few days only. If  
given to ship them

## "TWO REAL

Dodge Coupe  
car for private use  
1921 Nash 7  
extra equipment. I  
covers and will m  
Special terms on e

Then we hav  
Dodge Com  
Ford Coupe  
Hudson Sup  
1921 Essex

FIG. 78

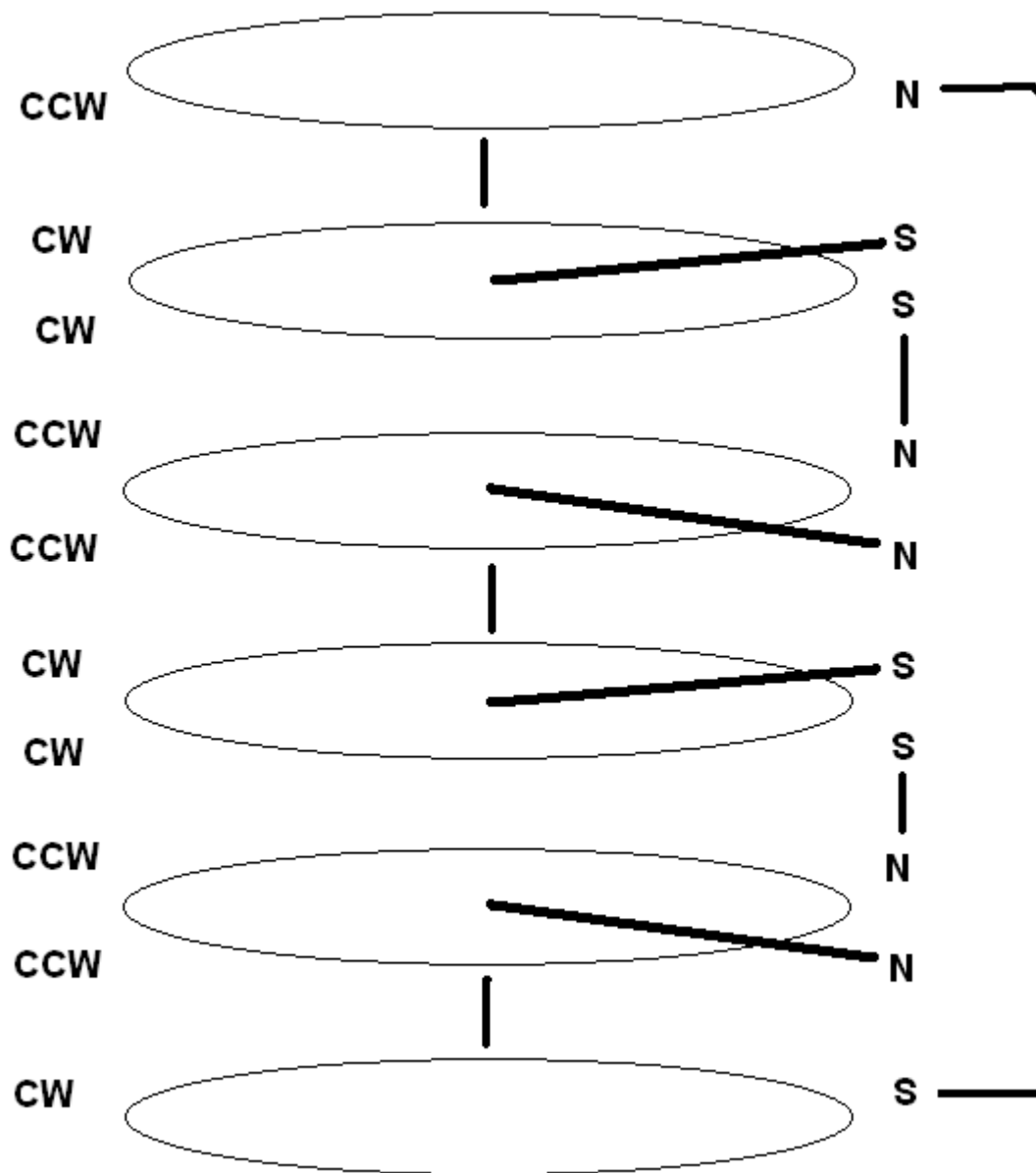

FIG. 79

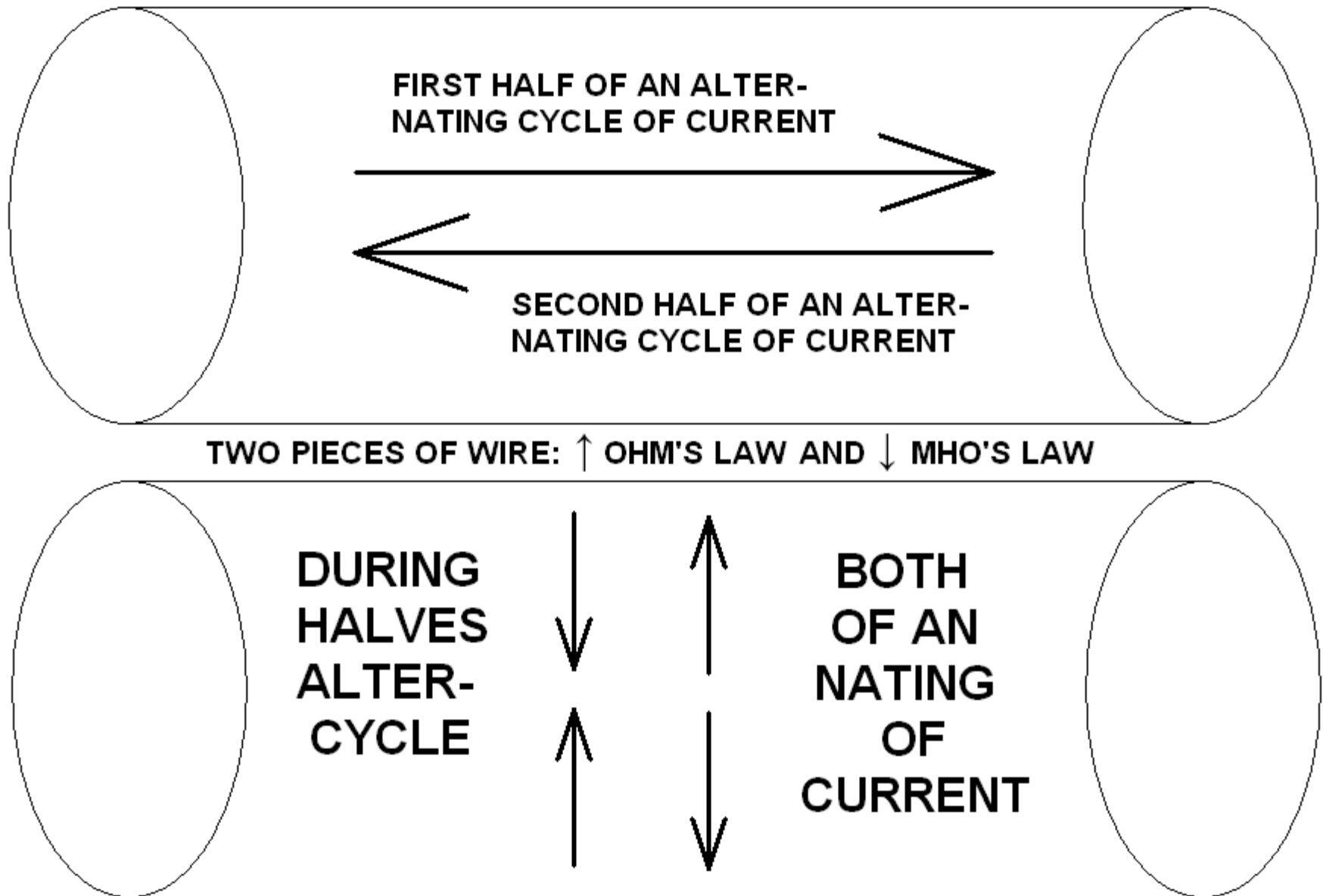

FIG. 80



# THE GENERATION OF REACTIVE POWER FROM AN LRC CIRCUIT OF HEIGHTENED IMPEDANCE VIA THE MODIFICATIONS WHICH ARE POSSIBLE WITHIN, AND SURROUNDING, AN ELECTROSTATICALLY ENERGIZED GAP OF AIR OR NOBLE GAS<sup>1</sup>

## FIELD OF THE INVENTION

The present invention relates generally to electricity. More specifically, the present invention is an LRC “tank” circuit of heightened impedance<sup>2</sup> made manifest in the form of an electrostatically energized gap of air or noble gas which is internally, or externally, modified to generate reactive power sufficient to power an appliance of large demand, such as: an electric motor within an electric vehicle, exclusively utilizing input derived from the ambient energy of the immediate environment surrounding this invention.

## BACKGROUND OF THE INVENTION

There is no background. All we have are anecdotal bits and pieces of storyline, but no full-length story – much less, any hard evidence. The newspaper article from 1921 does not do any justice since it's a very short treatment of this subject. All we know is that the Ammann brothers did something which made headlines and one of the brothers was arrested for “stealing energy from the grid.”

We know even less about Tesla's TriMetal Generator.

I had a friend, who is an electrician, who knew another coworker nearly two decades ago in Kansas, who demonstrated a device the size and shape of a notebook which ran a motor which his friend called: a trimetal generator since it was composed of the three metals of aluminum, copper and iron.

## SUMMARY OF THE INVENTION

---

1 A copy of this text can be found here... → <https://is.gd/ixabub> = [http://vinyasi.info/mhoslaw/Patents/second%20attempt/draft%203/text\\_v2.pdf](http://vinyasi.info/mhoslaw/Patents/second%20attempt/draft%203/text_v2.pdf) and is complimentary to its figures... → <https://is.gd/econut> = [http://vinyasi.info/mhoslaw/Patents/second%20attempt/draft%203/figures\\_v2.pdf](http://vinyasi.info/mhoslaw/Patents/second%20attempt/draft%203/figures_v2.pdf)

2 “Electrical Impedance” → <https://is.gd/uxawib> = [https://en.wikipedia.org/wiki/Electrical\\_impedance](https://en.wikipedia.org/wiki/Electrical_impedance)

The TriMetal Generator of Nikola Tesla<sup>3</sup> is the Solution to the Mystery of the Ammann Brothers' Atmospheric Generator Demonstration of 1921 in Denver, Colorado<sup>4</sup> and the Inherent Overunity of Copper, Aluminum & Iron Orchestrated by the Ionizing Influence of an Air Gap. This refutes Tesla's Electric Car Hoax of 1931 (Wikipedia)<sup>5</sup>

Peter Savo reported, in an interview, that Tesla purchased 12 radio tubes. Forgetting for the moment his lack of credibility since he claimed he was Tesla's nephew, and also ignoring his lack of expertise on the subject of vacuum tubes, it's quite possible that this story is not a fabrication at all. It's quite possible that it actually happened. In fact, my motive for promoting my invention is to solve the mystery of, not merely the Ammann brothers, but also of Nikola Tesla's Pierce-Arrow demonstration ten years afterward.

Wikipedia credits Nikola Tesla with the invention of the vacuum tube capacitor.<sup>6</sup>

It's quite possible that, what Peter mistook for radio tubes (because that's all he knew about) may have, in fact, been: 2 diodes, 6 capacitors and 4 gas discharge tubes functioning as spark gaps. That is the inventory of the improved simulation of my speculation of resolving the Ammann brothers' mystery at FIG. 65.

*The Ammann brothers may have taken 1) two electrostatic gaps made of copper or bronze and filled them with air in the shape of hollow copper spheres, and 2) connected both spheres with a hollow copper tubing, and 3) fill the interior of each sphere and their interconnected tubing with a dielectric and paramagnetic material, such as: our modern-day use of tantalum (or the use of aluminum in their day) in the shape of metallic wool or bare wire or oxidized powder, and 4) pass the tubing through the center of a coil of insulated, or non-insulated, iron wire and 5) magnetically coupled this coil to an inductive load to electrically isolate this whole arrangement from the*

---

3 Reference to the use of the word “Tesla” within the context of this document refers to the native of modern-day Croatia and an immigrant to the United States, also known as: Nikola Tesla, born: 10 July 1856 and died: 7 January 1943, and is not to be confused with Tesla Motors,<sup>TM</sup> an American manufacturer of electric motor vehicles.

4 “C. Earl Ammann’s Cosmic Electric Generator” → <https://is.gd/omobjj> = [http://fuel-efficient-vehicles.org/energy-news/?page\\_id=971](http://fuel-efficient-vehicles.org/energy-news/?page_id=971)

5 “Nikola Tesla Electric Car Hoax” → <https://is.gd/yogofe> = [https://en.wikipedia.org/wiki/Nikola\\_Tesla\\_electric\\_car\\_hoax](https://en.wikipedia.org/wiki/Nikola_Tesla_electric_car_hoax)

6 “Vacuum Variable Capacitor, Invention” – Wikipedia → <https://is.gd/teslacap> = [https://en.wikipedia.org/wiki/Vacuum\\_variable\\_capacitor#Invention](https://en.wikipedia.org/wiki/Vacuum_variable_capacitor#Invention)

*load to insure its abundant production of reactive power so that it won't matter whether these electrostatic gaps are ON by way of arcing into a plasma or they are OFF by way of preparing themselves for an arc to form by ionizing its gas. 10) Instead, **it may have been best if this electrostatic gap is always OFF to insure a nice, smooth, hyperbolic rate of escalation of its output. If this electrostatic gap were to turn itself ON (by arcing, or firing up, into a plasma), then the overunity benefits of their invention would escalate at a vertical rate of explosive amplification rendering their invention non-manageable.** This is a very important set of conditions for them to have kept in mind when they were operating their device.*

*Verification for the overunity condition of their invention is by way of a segregated analysis of its analogous simulation.*

THIS CONSTITUTES A REPLICATION OF NIKOLA TESLA'S, SOLID-STATE GENERATOR THAT WILL LAST FOR FIVE THOUSAND YEARS, REQUIRE NO MOVING PARTS, AND POSSESS NO PRIME MOVER OTHER THAN THE AMBIENT ENERGY OF ITS IMMEDIATE ENVIRONMENT, BUT REQUIRE THE 180° INVERSION OF THE PHASE OF VOLTAGE RELATIVE TO THE PHASE OF CURRENT GAINED BY ANY MEANS AVAILABLE!

The reason why nobody has ever figured out the equivalent connection between Tesla's TriMetal Generator, and Joseph Newman's device, and the Atmospheric Generator of the Ammann Brothers, is due to their use of air, rather than the use of a noble gas, as their ionizing medium inside of their copper spheres and copper tubing.

It's easy to take an ionized gas for granted (such as air, etc). Stanley Meyer never mentioned how dependent his invention was upon his ionization of air (specifically, the nitrogen inside of air). And Joseph Newman never mentioned his use of ionized helium despite this is exactly how he built his demonstration models according to the specifications given to him by Bryon Brubaker (an electrical engineer from Wabash, Indiana), and *contrary* to what Newman specified in his book (to use permanent magnets acting as rotors instead of helium canisters and each canister wrapped with an open coil not connected to anything). And the Ammann brothers got away with overlooking this salient fact whose lack of disclosure only helps to spread our misunderstanding of Tesla's TriMetal Generator wherein its use of three metallic substances is merely *supportive* of its primary use of the electrostatic ionization of an air gap.

Nikola Tesla called a spark gap a “disruptive discharge.”

A disruption is a random series of events effectively creating change, over time, to what would otherwise be a continuous condition

of non-change. To an electrically reactive component, such as: an inductor or a capacitor, this randomization of altering electrically reactive activity is as good as rotating an inductor or turning ON and then turning OFF a capacitor, mechanical switch whose two contacts are changing the distance between each other which effectively changes the threshold at which a spark gap (between these two contacts) will form an arc after preionizing this space between these two contacts.

Since power comes from a prime mover, and a prime mover injects change into a dielectric or a magnetic field, a spark gap – although seemingly stationary – injects the equivalence of motion that is equivalent to a continuous state of change over time (by inverting the phase of voltage with respect to the phase current) into neighboring reactive components (such as: an inductor, or a capacitor) and, thus, solves the riddle of what Tesla meant when he said that he had invented a “solid-state generator (of no moving parts) which would last for five thousand years and possess no prime mover.”

This is Tesla's TriMetal Generator which the Ammann brothers have managed to replicate.

Cosmologically speaking, if we wanted to find a celestial analog for this invention, then we might draw an analogy as to how our Sun, and other stars, hypothetically operate...

What we see lighting up our sky is *not* the generation of power. The photosphere surrounding our Sun constitutes its load; its impedance; causing a plasma to form around its hollow sphere lighting up our sky and warming our body. At the center of this hollow planet is a “dark star” which is defined as being similar to its photosphere with the difference that this dark star is not a plasma. It is merely an ionic sphere of electrical reactance; a preplasma, or protoplasma, of what it could become if it were to become thoroughly ionized into the state of an arcing plasma similar to a lightning bolt. If this dark star were to become completely ionized into a state of plasma, then our Sun would explosively die! But with a central dark star, this central sphere of protoplasma manages to generate all of the reactive power which our Sun requires to operate the photospheric electrical load at its surface by not generating real power, but by generating reactive power whose evidence for its darkened central presence cannot be seen. Only its consequential real power can be seen at the electrical load of our Sun's photosphere. Thus, it could be said of this dark star that it is invisible.

Thus, a true Tesla Coil acting as a power generator does not emit sparks, for this would be an indication of its acting as an electrical load consuming real power which can be seen. Rather, a true Tesla Coil emits a standing wave of reactive power whose wattage is zero due

to its voltage phase and current phase are out of sync with each other by one-half of an alternating voltage-cycle (180° of separation).

A standing wave is composed of two mathematical elements. Each of these elements cannot be seen. If these two elements were to synchronize their interaction, then these two elements would no longer be invisible; their union would be seen as an electrical load. But when these two elements cross-interfere out-of-phase by one-half of their alternating cycle, then a negative unity, power factor manifests – driven by *purely* reactive power – which is also equivalent to a standing wave of zero watts.

These standing waves are not reactive power of a 90° phase shift between voltage and current.<sup>7</sup> These standing waves are reactive power of a 180° phase shift between voltage and current, because it is *only* this type of a standing wave which is the most efficient at amplifying its volts/amperes to infinite oblivion without any loss of power while it is amplifying itself. Only then may it truly be said to be: lossless.

So, how many Tesla Coils does it take to produce this effect? Only one. A pair of Tesla Coils arcing between each other, and towards each other, is not a standing wave, nor is it a generator of invisible, reactive power. It is not a dark star.

The German diehard Nazis of the World War II era who studied this called it a “Black Sun”<sup>8</sup> and depicted it using a black swastika with 12 arms which were reversed from the normal direction of a Nazi swastika's spiral direction.

The most effective spark gap is a spark gap which is OFF - not arcing, nor in a state of being a plasma.

Dark stars don't have to always be at the center of a star or planetary body. They can stand on their own merit devoid of any hollow shell which could, in some instances, surround them and this shell could then provide an immediate opportunity to act as an electrical load and let us know of its location in space. Otherwise, they're invisible and, then, only their consequences are directly knowable.

Interestingly enough, some unseen object rotates around our skies on a 25 hour cycle due to an interesting test performed upon sunflower sprouts grown underground. Sunflowers tend to rotate with the Sun. That's why they're called: girasol in Spanish which means to

---

7 “Helicopter Aviation; Gyroscopic precession” → <https://is.gd/teguku> = <http://www.copters.com/aero/gyro.html>

8 This Naziesque term, I gleaned, from the perusal of either of two of Joseph H. Cater's books, entitled: “The Awesome Life Force” ISBN-10: [0787301612](https://www.amazon.com/dp/0787301612) or “The Ultimate Reality, Vol. 1 & 2” ISBN-10: [0787313408](https://www.amazon.com/dp/0787313408).

“rotate with the Sun.”

This test (which was made upon sunflower sprouts) caused them to rotate on a 25 hour cycle. The authors of the book (which wrote of this account in the 1970s) suggested that something, unseen, is circling our sky and this something is not our Moon, nor is it the Sun. It's something else....

I would suggest another supposition that sunflowers somehow remember a distant era when this planet rotated on a different schedule. Probably other explanations are possible?

Either way, whether the unseen celestial object is there right now, or is but a faint memory retained at the cellular level within the sunflower plant, either way its influence is analogous to unlit spark gaps empowering electrical loads (since plants and animals are electrical loads and unseen objects are potentialities capable of having an influence over more obvious and active elements of nature).

It is important to make these distinctions due to the misguided and erroneous information which is held to be “true common knowledge” concerning Tesla Coils by, and among, those people who consider themselves to be well-schooled in this artistry.<sup>9</sup>

By the way, a “true” Tesla Coil must be fully in resonance to create a standing wave without emission of streamers or sparking from its exterior. Partially in resonance is not enough and merely indicates an ongoing attempt, by whomever is managing this type of coiled device, to achieve resonance without having achieved resonance yet.

Also, Tesla built the terrestrial antenna for his Wardencliff Tower embedded in dielectrical bedrock far beneath the conductivity of the topsoil above this bedrock to utilize the dielectric properties of the bedrock to effectively make use of the preexisting resistance and impedance (rather than try to avoid, or overcome, it) which might have otherwise thwarted the efficiency of his endeavor to transmit communications and power, wirelessly, to distant locations on this planet had he done so utilizing our “modern-day” misunderstanding of Tesla Coils.

Any Tesla Coil which remains true to this standard of construction and operational detail also remains true to Nikola Tesla's vision

---

<sup>9</sup> “The Tesla Files” on the History Channel; five episodes aired May 3<sup>rd</sup> through May 31<sup>st</sup> during its first season in 2018. → <https://is.gd/umijis> = [https://watch.amazon.com/detail?asin=B07RZH68ST&territory=USA&ref\\_=share\\_ios\\_season&r=web](https://watch.amazon.com/detail?asin=B07RZH68ST&territory=USA&ref_=share_ios_season&r=web)

for the Magnifying Transmitter stationed inside of the laboratory which was adjacent to his Wardenclyffe Tower.

Only by making a thoroughly segregated analysis has it been possible to make these discoveries about spark gaps and draw these conclusions about black suns and be capable of distinguishing between Tesla Coils which are inferior to those which are not inferior (by Tesla's standards) assisted by Eric Dollard who has (during at least one of his many presentations) pointed out this distinction between Tesla Coils which remain true to their inventor and those which are in error.

This cosmological rendition of my invention is analogous to the Science of Creative Intelligence™,<sup>10</sup> espoused by its author: Maharishi Mahesh Yogi,<sup>11</sup> in as much as the quiet center of our Sun represents Intelligence while the outer photospheric plasma constitutes Energy and the calcium ferrite hollow shell of our Sun held in between the outer lit photosphere and the inner unlit dark star is functionally analogous to the iron winding surrounding the Ammann brothers' invention in that it Creates a conversion of reactive power, emanating from out of the darkened central core of our Sun, and then converts this into real power radiating from its electrically loaded photosphere.

We made a mistake over a hundred years ago when we set out to search for an “absolute frame of reference” and then claim that we could not find any. Hence, we concluded that such a frame of reference does not exist and replaced that concept with the concept of relativity.

We could have found what we were looking for if we had properly understood *what* we were looking for.

So, it's not that we did not find an absolute frame of reference, but that we failed to find our misunderstanding of an absolute frame of reference. Since misunderstandings don't exist except in our delusions, it makes sense that we never found our delusion to exist within the realm of cosmology.

So...

---

10 “What is the Science of Creative Intelligence?” – Maharishi Mahesh Yogi, Maharishi International University, posted to YouTube on 13 April 2009 → <https://is.gd/zireta> = <https://youtu.be/TAyZIJl2oSw>

11 “What is the connection between the Science of Creative Intelligence and Transcendental Meditation?” – Maharishi Mahesh Yogi, Humboldt, 1972 → <https://is.gd/gehafu> = <https://youtu.be/uRkLI0VX6ko>

Let's correctly redefine what we mean by an absolute frame of reference. And then, let's go and locate it and *this time* find it!

But to do that, we must first redefine something else which we have mistakenly deluded ourselves into entertaining incorrect thinking regarding the concept of *inertia*. And ask ourselves the parallel question of, “from where does inertia arise?”

Inertia is a property of space. It is not a property of matter. But we have to clear up a third misconception in order to see why this is so.

Space is the ultimate, “a priori”, source for inertia via the impedance which space offers all matter against the movement which matter wants to engage in. Motion is the inherent nature of matter while impedance to movement is the inherent nature of space.

By way of the density of matter, space gives up its impedance to motion by way of displacement based on how much of space is displaced by how dense is the matter attempting to occupy that space.

Space is not simply something to fill with matter as if space were empty. No.

Space is the ultimate frame of reference in as much as space is the ultimate source for impedance to motion among objects of matter.

And space is the ultimate source for matter since matter is derived from space as a variation of spatial properties.

In exchange for matter's occupation of space, space gives up its impedance to motion and imparts this property to matter. The degree to which how much of this impedance is sacrificed by space is determined by the density of matter. The more matter which exists per unit of space, the more dense is that matter which means there will be less space in between the molecules and atoms of that matter to be empty. Instead, there will be more matter filling that space and less space which is empty if that matter is very dense. Hence, we may also say that all matter is made of space. Matter is not made from, nor made of, anything else other than space. Thus, we mistakenly conclude that it is matter which possesses the property of inertia when in fact it is space which is the ultimate, a priori, absolute, source (frame of reference) for impedance to motion which we call: inertia.

Thus, it is this impedance to motion which is the absolute frame of reference which we had failed to search for and, thus, did not find. This property of space is the ultimate prime mover.



So, now, we have to redefine what is a prime mover.

A prime mover is ultimately derived from the impedance which space offers to the movement of material objects (which occupy space) and, thus, the ultimate prime mover is scientifically measured and appreciated as inertia.

It is this inertial prime mover which allows for free energy since only when we offer very little voltage to a circuit does this ultimate prime mover demonstrate itself capable of surpassing inertia by feeding off of inertia to accumulate a vast storehouse of voltage buildup resulting from the impedance which is inherent within all free energy circuits which take advantage of the benefit which the impedance to motion (namely, the electrical motion we know of as: current) imparts to these types of circuits.

In other words, unlike conventional circuits which fight inertia by utilizing vast voltages to overcome impedance within a circuit (which will result in the production of some limited quantity of current which reaffirms our belief in thermodynamics as a self-fulfilling belief), a free energy circuit never overwhelms itself with excessive voltage so that the reactance of a free energy circuit may foster the accumulation of voltage all on its own derived from the spatial property of inertial impedance. This invokes the domain of Mho's Law (there is more to be said on this subtopic later on in this discussion).

When this voltage is magnetically transferred to a self-shortened coil, with an electrical isolation placed between the shorted coil and the reactive components within the circuit which produces it, current -then- arises within this shorted coil along with the a massive momentum standing behind this current in the form of a massive quantity of voltage which we have allowed to accumulate arising from our having fostered reactance by not suppressing it with a massive input of voltage carrying its own frequency as its carrier wave.

The buildup of reactively generated voltage tends to follow its own acceleration of frequency which coincides with this buildup of voltage. To inject any sizable quantity of voltage from outside the circuit also injects its own standardized frequency which thwarts the self-regulation of self-generated acceleration of frequency arising from out of the same process which manifests a reactive amplification of more voltage.

This injection of considerable voltage coming from outside of any free energy circuit is a hidden danger of immediate failure. It's not the excessive voltage, alone, which thwarts the generation of free energy so much as it is also the imposition of an exterior source of

frequency which hampers the freedom of a free energy circuit to decide for itself what frequency it may create to orchestrate the manifestation and amplification of free energy.

So, for free energy to flourish, we should never supply a circuit with any noticeable quantity of voltage to speak of. Instead, we should supply a free energy circuit with as little voltage as we can get away with and foster the development of reactance using the techniques of electrical reactance, namely: frequency, phase relation, duration, capacitance and inductance. These five qualities will produce whatever quantity of reactive power which we desire to obtain from the free energy circuit, alone, and not from any exterior source of power. The only efficient use – of exterior sources of power – is to use them to serve as mere stimuli for the escalation of freely available, reactive power and not for their exclusive dependency – *unless we want to subscribe to our total dependency upon purchasing these exterior sources of power for our livelihood and survival from anyone who will not give away this energy for free!*

We don't need more energy than what is already available surrounding us as a background field whose default status is mere micro volts. Nor do we need to feed our circuits with lots of energy, in order for our circuits to exhibit abundant energy. All we need is very mild stimuli to catalyze the production of our own energy and foster our circuits to develop and amass reactance to use this reactance as if it were energy since there's not much difference between the two, anyway!

A counter-wound pair of coils (connected in parallel with each other) comes to mind, right off the top of my head, as an example of how to use reactive power to impart rotation to a motor since the amperage of one winding will be in-phase with the voltage of its complimentary winding, and the amperage of the second winding will be synchronous with the voltage of the first winding. Thus, both windings may be utilizable at full wattage of positive unity power factor.

And a simple resistor gives forth heat when reactive power activates said resistor. This is another way to utilize reactive power at full wattage of positive unity power factor.

And magnetic coupling between two inductors preserves a highly reactive voltage on one side of this magnetic coupling while allowing for the formation of real or reactive current within a self-shortened coil on the other side of this magnetic coupling which will allow for the transfer of a humongous quantity of volts/amperes, or wattage, to back up the power of the self-shortened coil.

See how easy it is to understand free energy?

If we have a proper understanding of inertia, and space, and absolute frames of reference impeding the motion of material objects displacing the inertia of space by way of the density of their matter (and, thus, exchanging {transferring} the inertia of space to matter), then we will have no problem – at all – understanding free energy as an outgrowth of the prime mover of space (which opposes the movement of material objects attempting to move through space).

So, prime movers don't move; they stand still! They are not filled with energy; they're filled with inertia.

And inertia is the ultimate source for free energy to materialize any quantity of energy for free.

The moral of this story is that, if we look in the right place for whatever we are looking for, then we'll find what we are looking for. Otherwise, looking in the wrong place will just waste our time, our patience, our perseverance, and our tolerance for thinking outside of the limitations which are inherent within our conformist style of thought-patterns.

We can't afford to look in the wrong place and come up empty-handed. No.

Never again will we make this mistake...

As an aside...

Our Earth was imported from a star located in the Pleiades to replace a planet (called: Maldek) which was orbiting between Mars and Jupiter and blew up, thus, depriving our Sun of an adequate electrical load to dissipate its generation of reactive power. For, without an adequate load to encourage dissipation and prevent accumulation of stagnant power, the continuation of the generation of reactive power would have exploded our Sun. Like a balloon which is continually blown up with air, it will eventually explode, likewise would our Sun have done the same had the Earth not been provided to “balance the load” as electrical engineers in charge of managing the power grid like to call it. All of the cetaceans that we know of (dolphins, Orcas – killer whales, sperm whales, porpoises, etc) were on board at the time that this Earth was removed from the Pleiades and brought here.

Our Sun was in danger of turning ON its inner neon bulb. Its outer neon bulb was already ON. That's the photosphere which we see

as being lit up in our daytime sky giving us warmth and light. But its inner neon bulb was OFF and remains OFF to prevent an escalation of the accumulation of reactive power which is a vertical slope of explosive force when graphed against the passage of time. Otherwise, when this inner neon bulb of a star (our Sun) remains OFF, the slope of this escalating curve of accumulating amplitude of reactive power (which is generated by the inner neon bulb of all stars) is a nice, smoothly gradual, hyperbolic incline of accumulative reactive power. And if there is an adequate electrical load of planetary masses to dissipate a star's energy towards that star's solar system, then that star will not turn ON its inner neon bulb, because the energy which that star is constantly creating will dissipate at an adequate rate to prevent its buildup within the interior of that star. Instead, its planetary electrical loads will grow in size and grow in electrical activity instead of their star growing and expanding the accumulation of its electrical power. This transference of electrical growth and growth of (gravitational) mass from a star to its surrounding planets maintains stability of the operation of that star and helps to preserve that star's long life. Otherwise, that star would become a nova, or a supernova, and destroy itself.

The inner surface of our Earth has an atmospheric sky. But unlike our outer sky, the inner sky of the Earth is lit up throughout the entire volume of atmospheric material. It is self-luminous. This means that the inner sky is behaving not unlike the outer photosphere of the Sun in that an inner neon bulb (located at the center of our planetary Earth) is OFF and transferring its energy outwardly to become manifest as electrical loads.

I would imagine that some crazy scientist on the planet Maldek got the silly notion in his head, one day long ago, to turn ON the inner neon bulb of his planet as if to suggest that the self-luminous condition of his inner sky was not enough to light up and warm his world on the inner surface of his planet. That's incredibly stupid. Or else their orbital path was too far away from our Sun to get adequate heat and light to warm and light up the outer surface of their planet so he decided to increase the electrical activity of the inner neon bulb of his planet which led to its explosive escalation resulting in its self-destruction using the same mechanism of excessive accumulation which a star will undergo under similar conditions of instability brought on by both inner and outer neon bulbs of either a planet or a star being both ON rather than the inner neon bulb always remaining OFF and the outer neon bulb remaining always ON.

The reason why the atmosphere surrounding the outside of our Earth is not always ON (arcing into a state of a plasma) is because it is dissipating its energy out into space. But on the inside, it cannot dissipate any energy since any dissipation coming from one inner side of a

planet or star will simply jump to the opposite inner side of that planet or star and never leave the inside of that planet or star fast enough to dissipate and not energize the inner sky into a self-luminous condition. Consequently, the inner sky of a planet is always lit up while the outer is not lit up and must get its energy from elsewhere. In the case of our planet Earth, its outer surface gets its energy from the Sun. But in the case of the outer surface of our Sun, it manages to turn its outer neon bulb ON due to there being not enough planets to act as electrical loads to dissipate the Sun's energy so rapidly as to prevent the Sun's outer neon bulb from turning itself ON due to the accumulation of its inadequate dissipation of energy.

This is what I glean from the segregated analysis of a spark gap which has been modified per the instructions laid bare in this document. These modifications are inside the spark gap, or else they are outside and nearby the spark gap as a configuration of electrical components.

#### INTRODUCING THE INVENTION

“Mho's Law Justifies Free Energy,” by Vinyasi – Monday, 14<sup>th</sup> of July, 2021.

How to generate an endless supply of reactive power by studying the behavior of spark gaps.

This is an attempt to replicate Tesla's TriMetal Generator and the Atmospheric Generator of the Ammann brothers which may be one and the same invention.

Mho's Law mathematically justifies free energy and defines the limited jurisdiction of the Conservation of Energy Law which exclusively pertains to Ohm's Law and the consumption of real power. The Conservation of Energy Law does not pertain to the generation of reactive power.

Voltage sources do not generate real power. They merely generate reactive power due to the definition of a negative polarity assigned to the electric charge of an electron versus the positive polarity assigned to the voltage difference between the two terminals of a voltage source.

Only electrical loads consume real power. Thus, only appliances come under the authority of the Conservation of Energy Law by requiring that their reception of real power must equal their exportation of the conversion of this inception of electrical energy into some

other format. For instance, an appliance may receive real power, but must convert this into an equal amount of heat energy or mechanical motion, etc, in order to satisfy its operation under the Conservation Law and Ohm's Law.

The reactance formulae of capacitive and inductive reactance regulates the rate of the formation of free energy while Mho's Law justifies it.

Here is a copy of my application for a provisional patent. It comes in two volumes. This is Volume 1 containing text without images. Volume 2 must be purchased along with Volume 1 in order to follow along with the text. Or else, download the figures from my website using the URL from footnote #1, above.

The text follows a format analogous to Euclid's Axioms in which a simple premise serves as the foundation for whatever follows, namely: the conventional nomenclature of physics has decided to assign a negative polarization of sign to the charge state of an electron, plus we have casually accepted the convention of labeling the voltage difference between the two terminals of a battery as having a positive polarity of sign. From these two premises evolves a segregated analysis of several circuits which are simulated in Micro-Cap<sup>12</sup> electronic simulator.

Interestingly enough, electrical reactance formulae implies the magnification of conductivity over time, such that: any alteration of frequency could result in an increased or decreased asymmetry – of either the production of volts/amperes or the consumption of power per unit of duration – under Mho's Law due to the introduction of impedance substituting for resistance.

Impedance is defined in terms of either inductive or capacitive reactance, such that: inductance is equivalent to inductive reactance and capacitance is equivalent to capacitive reactance. Impedance also defines inductance is the multiplicative and additive inverse of capacitance and capacitance as being equivalent to the multiplicative and additive inverse of inductance...

*L = Inductance*

*C = Capacitance*

---

12 Spectrum Software™ → <http://www.spectrum-soft.com/>

$X = \text{Reactance}$

$\omega = \text{Angular Frequency} = 2\pi f$  ...<sup>13</sup>

$X_L = \text{Inductive Reactance}$

$X_C = \text{Capacitive Reactance}$

$$X_L = \omega L = 2\pi fL \tag{\S 1a}$$

$$X_C = -\frac{1}{\omega C} = -\frac{1}{2\pi fC} \tag{\S 1b}$$

$$X = X_C + X_L = \omega L - \frac{1}{\omega C} \tag{\S 1c}$$

The parallelism between Mho's Law versus Ohm's Law and between Inductive and Capacitive Reactance is uncanny. Both Mho's Law (§3x) and Capacitive Reactance (§1b) are the multiplicative and additive inverses of Ohm's Law (§2x) and Inductive Reactance (§1a), respectively, suggesting a non-intuitive equivalence between conductivity and capacitive reactance. This is non-intuitive (under Ohm's Law and the Conservation of Energy Law) since the resistance of the dielectric of a capacitor is infinite. Yet, it is this resistance which converts a capacitor into a super-conductor at room temperature whenever the phase of voltage shifts out-of-phase with current by one-half cycle of alternating voltage. Thus, capacitance can generate reactive power – as a consequence of super-conductivity – under Mho's Law. And this generation of reactive power can only be appreciated (ie, utilized) as real power under the inductively reactive influence of Ohm's Law.

Impedance is nothing more than resistance taken to a whole new level of complexity greater than the simplicity of mere resistance since impedance is the total resistance of power, or conductivity, as it changes over time within the context of alternating voltage (which is what we should be labeling our power supply instead of the slightly misleading term of alternating current).

Mere resistance doesn't change over time within the context of direct current (non-alternating voltage).

---

<sup>13</sup> “Angular frequency” → <https://is.gd/onihev> = [https://en.wikipedia.org/wiki/Angular\\_frequency](https://en.wikipedia.org/wiki/Angular_frequency)

Without the frequency of a periodic, or impulsive, alteration of voltage, impedance cannot be introduced to substitute for resistance within the formulae of either Ohm's Law or Mho's Law. But outside of the limited context of direct current, impedance translates into inductance and capacitance becoming sources for power in as much as they become sources for regulating conductivity which can alter power over time by making it diminish or increase regardless of the amplitude of any exterior prime mover.

This is why I claim that Mho's Law defines, and justifies, free energy while electrical reactance formulae regulates it, because – under Mho's Law, resistance(impedance) is our friend (for it does not compete against us) due to resistance(impedance) is located within the numerator of Mho's Law rather than located in the denominator of Ohm's Law (see, formulae §2x and §3x, below). So, the more impedance is available – in the form of inductive and capacitive impedance, then the greater is the conductivity of a circuit whenever its phase of voltage is one-half cycle out-of-phase with its phase of current.

This is why the output of my invention excels over its thermodynamic losses whenever the inductance of **L2** and the capacitance of **C5** (within FIG. 51 and FIG. 65) are sufficiently high enough (yet, not too high) resulting in a gain of reactive power accumulating over time superseding any thermodynamic losses within the same time frame.

Physics defines current as arising from the negative pole/terminal of a voltage source, such as: a D/C battery. In agreement with this convention of nomenclature, physics also defines current as consisting of negatively charged electrons. And batteries define their voltage in terms of the net positive voltage located at the positive pole/terminal of their device. Thus, do batteries define their generation of current with an inverse polarity relative to their voltage. So, if the recharging current of a battery is applied against its positive terminal, then this current is positive while the polarity of the voltage applied to facilitate this recharging current is negative. Or, if the current which exits from a battery undergoing discharge is negative, then its voltage is positive while its current is negative. This is the behavioral characteristic of the generation of reactive power coming from a battery, or a rotary generator, or a condition of recharging a battery with generative power in which voltage and current are in 180° opposition between their phases. This is not energy in the usual sense since this is not an electrical load wherein consumption is taking place.

Electrical engineering defines energy as an ideal condition exclusively pertaining to resistors in which the power factor is positive one (unity) indicating no loss of the efficiency of power whenever the phase angle between current and voltage is in mutual alignment with



each other and with zero degrees of separation between them. Only under this circumstance does Ohm's Law exclusively apply defined by the mathematical relation of...

$$Power = \frac{Voltage^2}{Resistance} \quad \text{\$2.1a}$$

What makes this relationship, of §2.1a, practical is the relation of §2.1b...

$$Power = Voltage \times Current \quad \text{\$2.1b}$$

...which has resulted from the extraction of §2.2a...

$$Current = \frac{Voltage}{Resistance} \quad \text{\$2.2a}$$

...from equation §2.1a, above...

$$Power = \frac{Voltage^2}{Resistance} = Voltage \times \frac{Voltage}{Resistance} = Voltage \times Current \quad \text{\$2.1ab}$$

...to create §2.1b as a shorthand version of §2.1a which makes the following relationships possible as a consequence, besides §2.2a...

$$Resistance = \frac{Voltage}{Current} \quad \text{\$2.2b}$$

...and...

$$Voltage = Resistance \times Current \quad \text{\$2.2c}$$

Anything other than watts, namely: other than real power, is purely informational in the form of a measurement of volts versus a measurement of amperes, called volts/amperes (VA), which is not considered to be energy, per se, but is considered to be reactive power: a fragmentation of power into its constituent ingredients of magnetism and dielectric potential per units of duration.

The resistance of Ohm's Law defines power (measured in watts) whenever the polarity of current matches the polarity of voltage (ie,

positive polarity of voltage versus positive polarity of current; or, negative polarity of voltage versus negative polarity of current). Current flows from areas of high voltage towards areas of lower voltage under Ohm's Law.

The relation which is inversely related to (the mathematical reciprocal, or multiplicative inverse, of) power is the relationship of admittance<sup>14</sup> (conductivity, G, measured in Siemens; formerly measured in units of “mho”,  $\mathcal{O}$ ). This had been named: Mho by Lord Kelvin,<sup>15</sup> before it was superseded by Siemens, and I endorse and will revive the use of Mho as a Law for the purposes of this discussion, in which the polarity of voltage is opposed to the polarity of current. So, whenever the voltage of conductivity has a polarity of positive sign value, then the polarity of the current of conductivity is signed negative. And whenever the voltage of conductivity has a polarity of a negative sign value, then the polarity of the current of conductivity is signed positive. This effectively inverts voltage so that current flows from areas of low voltage towards areas of higher voltage creating a condition which has colloquially come to be known as: negative resistance<sup>16</sup> (although, as we'll see in a minute, it is more accurately {puritanically} described as being negative voltage)...

$$\text{Conductivity} = \frac{\text{Resistance}}{-\text{Voltage}^2} \tag{§3.1a}$$

What makes this relationship, of §3.1a, practical is the relation of §3.1b...

$$\text{Conductivity} = \frac{\text{Current}}{\text{Voltage}\sqrt{-1}} \tag{§3.1b}$$

...which has resulted from the extraction of §3.2a...

$$\text{Current} = \frac{\text{Resistance}}{\text{Voltage}\sqrt{-1}} \tag{§3.2a}$$

...from equation §3.1a, above...

---

14 Admittance → <https://is.gd/fupene> = <https://en.wikipedia.org/wiki/Admittance>

15 “Siemens (unit), Mho” → <https://is.gd/tidose> = [https://en.wikipedia.org/wiki/Siemens\\_\(unit\)#Mho](https://en.wikipedia.org/wiki/Siemens_(unit)#Mho)

16 Negative resistance → <https://is.gd/negresist> = [https://en.wikipedia.org/wiki/Negative\\_resistance](https://en.wikipedia.org/wiki/Negative_resistance)

$$\text{Conductivity} = \frac{\text{Resistance}}{-\text{Voltage}^2} = \frac{1}{\text{Voltage}\sqrt{-1}} \times \frac{\text{Resistance}}{\text{Voltage}\sqrt{-1}} = \frac{\text{Current}}{\text{Voltage}\sqrt{-1}} \quad \text{\S 3.1ab}$$

...to create §3.1b as a shorthand version of §3.1a which makes the following relationships possible as a consequence, besides §3.2a...

$$\text{Resistance} = \text{Voltage}\sqrt{-1} \times \text{Current} \quad \text{\S 3.2b}$$

...and...

$$\text{Voltage}\sqrt{-1} = \frac{\text{Resistance}}{\text{Current}} \quad \text{\S 3.2c}$$

Ohm's Law defines the symmetry of entropic thermodynamics, namely: the symmetry of the Conservation of Energy (which should be renamed: the Conservation of Consumption), in which the volts and the amperes are both real numbers and their multiplication with each other will always result in a positively signed outcome implying the Consumption of Energy.

Electronic simulators don't have Mho's Law built into their design. Their engineers have assumed that Ohm's Law defines everything due to their assumption that entropy defines everything and under all circumstances, including the generation of reactive power. Thus, do they impose the presumption that the Conservation of Energy applies to all circumstances and Mho's Law does not exist as a viable option to compliment Ohm's Law. These presumptions are due to engineers assuming that external prime movers (ie, prime movers which are outside of circuits contributing their energy as an input towards the circuit's outcome) are always needed to engage the generation of reactive power and that circuits cannot, or should not be allowed to, do this on their own (acting as their own prime mover) and should not be allowed to demote the use of externalized voltage inputs to the status of mere stimulants. Stimulants merely motivate this process (acting as a catalyst) and encourage the circuit to avoid its exclusive dependency upon external support due to the fact that stimulants are defined by Mho's Law as having the greatest impact whenever a circuit's input voltage is severely reduced while taking advantage of an increased resistance and an increased impedance (whenever the inversion {negation} of voltage occurs) which actually favors a beneficial outcome of increasing conductivity and the overunity of a circuit's output through the use of the following relationship inherent within Mho's Law and derived from Ohm's Law...

$$\text{Conductivity} = \frac{\text{Resistance}}{-\text{Voltage}^2} \quad \text{\S 3.1a}$$

Mho's Law defines the asymmetry of negentropic thermodynamics, namely: the asymmetry of the Production of Energy, in which the volts and the amperes are both imaginary numbers and the division of resistance by an imaginary voltage yields a current which, when divided by an imaginary voltage (again, to create a squared voltage) yields a negative conductivity and implies the Production of Energy via enhanced conductivity at room temperature (without the need to supercool anything to nearly absolute zero degrees Kelvin)...

$$\text{Conductivity} = \frac{\text{Resistance}}{-\text{Voltage}^2} = \frac{1}{\text{Voltage}\sqrt{-1}} \times \frac{\text{Resistance}}{\text{Voltage}\sqrt{-1}} = \frac{\text{Current}}{\text{Voltage}\sqrt{-1}} \quad \text{\S 3.1ab}$$

Poor Lord Kelvin is probably squirming in his grave due to nobody is seriously taking his suggestion of utilizing the conductivity, and the super-conductivity at room temperature which Mho's Law is capable of, as the complimentary concept to the resistivity of Ohm's Law. Instead, his suggestion has been replaced by naming absolute zero degrees temperature after him rather than taking his advice and actively pursue super-conductivity the easy way! Instead, we pursue super-conductivity the hard way making it difficult for the common man to benefit from cheap and readily available energy.

Mho's Law lays the foundation for free energy's existence. This is the reason why it has fallen out of favor for use by engineers and scientists, because it justifies free energy and this is against the dictates of industry having a monopoly on energy.

This type of industrial cartel was mentioned and described at length by President Eisenhower during his farewell address to the nation when his term of office was about to expire on the 17<sup>th</sup> of January 1961.<sup>17</sup> This cartel consists of an extremely binding relationship between commerce and military to do whatever it takes to further their mutual goals of the monopolization of energy and information. This requires governmental control, and commercial control, over energy and information and entertainment to exclude whatever truths could jeopardize their cartel. They have effectively disenfranchised us from transcending our exclusive dependency upon their authority.

---

17 "Eisenhower's Farewell Address to the Nation," → <https://is.gd/ahuleq> = <https://americanrhetoric.com/speeches/PDFFiles/Dwight%20D.%20Eisenhower%20-%20Farewell%20Address.pdf> and <https://is.gd/opohug> = <https://americanrhetoric.com/mp3clips/politicalspeeches/dwighteisenhowerfarewell.mp3>

Imagine how formidable a task it is to increase energy if voltage is a limited resource (which it is under Ohm's Law) and resistance is always excessively getting in the way of getting any power out of a circuit. Yet, if Mho's Law authorizes the excessive production of power, *not despite* the presence of resistance and the lack of voltage, but *requiring* these two conditions which – would be limiting conditions under Ohm's Law, yet – are encouraged under Mho's Law.

This is why Ohm's Law doesn't work very well for the generation of power, yet, describes the consumption of power very aptly. It is Mho's Law which describes the efficient generation of power at an extremely low cost to its operator. And it is the reactance formula,<sup>18</sup> of capacitance, inductance and frequency (and the use of:  $2\pi$ ), which describes the regulation of free energy spawned and authorized by Mho's Law.

We have had the dexterity of Mho's Law swept under the proverbial rug of ignorance by the substitution of Ohm's Law by its replacement with the Conservation of Energy Law. It is high time we forget about the craftiness of the Conservation of Energy Law in its ability to oversimplify the situation. Let us revive Mho's Law in partnership with Ohm's Law for a complete perspective on energy.

Current is a term designating a mathematical shorthand operating upon voltage versus resistance...

$$Current = \frac{Voltage}{Resistance} \tag{§1.2a}$$

...and...

$$Current = \frac{Resistance}{Voltage\sqrt{-1}} \tag{§2.2a}$$

And because the voltage of Mho's Law is both the multiplicative inverse of voltage (originally derived under Ohm's Law) as well as its additive inversion of signed polarity (positive voltage inverted into negative voltage, or else negative voltage inverted into positive voltage), then (consequently) the current which arises as a form of shorthand notation for these two laws takes on two qualities of: conventional current possessing the same polarity of sign as does voltage, while electronic current possesses a polarity of sign which is

---

<sup>18</sup> “Electrical Reactance” – Wikipedia → <https://is.gd/olavaf> = [https://en.wikipedia.org/wiki/Electrical\\_reactance](https://en.wikipedia.org/wiki/Electrical_reactance)

inverse to voltage. It is this latter condition of current, electronic current, which defines the generation of reactive power emanating from out of a voltage source, such as: a battery, or a rotary generator. Conventional current, on the other hand, is restricted to defining the consumption of real power and adheres to the Conservation of Energy dictum, namely: that the energy which enters into an electronic component (which is engaging in the consumption of this energy) must equal the energy which results from this conversion, such as: the heat arising from a resistor, or the mechanical motion of an electric motor, etc, consequently: “energy IN must equal energy OUT”.

Now do you understand the limited jurisdiction of the Conservation of Energy Law?

It's limited to the energy which enters into any electronic component which is engaging in the consumption of energy, namely: its conversion into some other format, such as: the conversion of electrical energy into heat or rotary motion, versus the heat or rotary motion which exits that component. So, if a resistive element has X units of electricity entering that resistor, then X units of heat must exit that resistor – no more and no less. That's it....that's as far as the limitations of physics can take their precious law of Conservation to and not proceed any further with it.

Equation §3.2a has been extracted (subtracted) from equation §3.1a to yield equation §3.1b....

$$\text{Conductivity} = \frac{\text{Resistance}}{-\text{Voltage}^2} = \frac{1}{\text{Voltage}\sqrt{-1}} \times \frac{\text{Resistance}}{\text{Voltage}\sqrt{-1}} = \frac{\text{Current}}{\text{Voltage}\sqrt{-1}} \quad \text{§3.1b}$$

If we hadn't done this and kept conductivity equaling the square of voltage having an inverse (negative) relationship with resistance and avoid the convenience of artificially creating the mathematical construct (ie, abstraction; pseudo-fiction) of current, then we wouldn't be dealing with an imaginary value for the super-conductive variety of current under Mho's Law (in contrast to the resistive variety under Ohm's Law). Instead, we'd be dealing (merely) with a negative square of voltage and be able to create a net total of summing the two subtotals of: reactive power (conductivity; generation), plus real power (resistivity; consumption) to arrive at an awareness as to whether or not a circuit's segregated analysis is symmetrically thermodynamic, overall, obeying the Conservation of Energy by automatically “balancing the load” in which reactive power generation equals the consumption of real power, or else it is deviating from this convention by being asymmetrically thermodynamic in which its generation of reactive power is greater than, or less than, its consumption of real power.

Electronic simulators won't tell us whether or not an electronic component is producing reactive power (acting as a generator). Yet, they still tell us whether or not a component's voltage is positive or negative and whether or not this same component's current is positive or negative and, thus, will tell us whether or not their product is positive or negative. Thus, it doesn't matter that we've confused the situation by ignoring Mho's Law since we can steer clear of this confusion with a proper understanding of what is *really* happening by reeducating ourselves on the significance of Mho's Law and what this has to offer in the way of explaining, and justifying, free energy.

What is *really* happening is that current travels towards areas of lesser voltages only within the domain of electronic components which are acting as consumers of real power, because it is only these components which are symmetrically obeying the Conservation of Energy. Meanwhile, current travels towards areas of greater voltages only within the domain of electronic components which are acting as producers of reactive power, because it is only these components which are asymmetrically obeying Mho's Law and the generation of reactive power which lies outside the jurisdiction of the Conservation of Energy. *{It is this latter condition which accentuates voltage differences, rather than equalizing them, which makes possible the accumulation of reactive power achieving infinite levels of amplitude.}*

In other words, current does not travel between and among components of a circuit. Being a mathematical construct, the domain of the traversal of current is strictly within the domain of the component to which this traversal is attached. Only voltage differences exist between components of a circuit. And only resistances exist within components of a circuit. Nothing else matters whenever seeking a tabulation of power and a segregated mapping intended to analyze what is happening.

Because of this pseudo-fictional creation of a mathematical construct, current has made it possible for us to take this construct one step further and misunderstand the situation so completely that we no longer understand energy much less understand free energy – in other words, we fail to understand and appreciate the limitations of real power versus freely available, reactive power.

Current is an artifice, an artificial construct, spawned by the mind of the mathematician intended to simplify the squaring of voltage for both Ohm's Law and Mho's Law. This is analogous, although not equivalent, to the mathematical pseudo-fiction of complex numbers. These mathematical constructs help to simplify the perspective of the electrical engineer performing the calculations of electrical engineering.

Since current does not exist in any ultimate sense, nor does the motion of the electron exist except as a mathematical resultant of

changes made to the levels of voltages at various locations in space. In other words, current is a derivative – not a fundamental property – of voltage and resistance. “Movement” is a fiction while “change” is not. The *apparent* existence of movement is what our brain wants to believe is true without any “a priori” foundation to its existence, but with an “a posteriori” authenticity derived from a lack of clarity and honesty. A study of these mathematics – of Ohm's Law and Mho's Law – reminds us of the Vedic perspective in which “all of this is Maya – illusion.”

But don't fight this illusion. Enjoy it for what's its worth.

Fighting it would be a mistake.

Let the senses and the mind satisfy themselves by their acceptance of this illusion for its face-value since they will continue to disagree with the mathematics (involved) by continuing to emphasize how real is this world of change despite our knowing better.

Philosophy (mathematics) cannot supersede experience. But it can flavor it; or, poison experience if we let it – which will result in an unnecessary state of depression.

It is better to enjoy this illusion than allow ourselves to become depressed about it.

You'll notice that all of the equations of §3xx involve either the square of voltage times negative one, or else the square root of negative one (the imaginary number, “i”) times voltage (which is not squared). This signifies the additive inversion (negation) of the phase of voltage by one-half cycle of alternations relative to the phase of current making these equations exclusively relevant to the generation of reactive power and enumerated by complex numbers. This is also signified by the versor algebra<sup>19</sup> operator of “i” for one-quarter cycle of alternations versus the square of “i”, or the versor operator of “-1”, for one-half cycle of alternations.

A quarter cycle, “i”, is due to either capacitive reactance or inductive reactance and is either “+i” or “-i” depending upon the circular direction of displacement within one cycle of alternations is occurring as the result of capacitive reactance shifting voltage backwards by one-quarter cycle, represented by “-i”, or else occurring as the result of inductive reactance shifting voltage forwards by one-quarter cycle, represented by “+i”.

---

19 “Versor Algebra,” by Eric P. Dollard → <http://versoralgebra.com/>



The generation of reactive power, represented by negative unity power factor, is a shift of voltage by one-half cycle of alternations and is, thus, represented by the square of “i”, namely: “-1”.

Fortunately, despite the shortcomings of collective confusion surrounding this topic, we can still get a grand total of energy accountability by adding up all of the subtotals of reactive power generation versus all of the subtotals of real power consumption (which electronic simulators provide us) since the summation of this pair of subtotals will be a real number of either negative or positive outcome indicating whether production of energy predominates or else consumption of energy predominates, respectively.

Thus, and most importantly, we can discover whether or not a circuit is symmetrical and whether it is entropically thermodynamic, or else is asymmetrical and negentropically thermodynamic. Looking at the equivalency of the absolute values of both subtotals will *suggest* symmetry versus non-symmetry, and is conclusive, because real power is the compliment to conductivity (reactive power). To attempt to add these two parameters together to come up with a grand total of a singular parameter is, also, possible, because each is the multiplicative inverse (integer versus fraction) and additive inverse (positive versus negative) of the other.

What comes out of a battery is not energy since its current is polarized  $180^\circ$  in opposition to the polarity of its voltage. Instead, what comes out of a battery is information in the form of volts/amperes (VA) also known as: reactive power. The chemistry of the battery is reacting to the closure of a switch causing the chemicals inside of a dry-cell battery to inter-react with each other which they would not have done had the switch (of this type of simple circuit which interconnects the two terminals of a battery) never have been closed.

This chemical reaction is potential power which we measure at the terminals of the battery as being a voltage difference between its two terminals. It becomes reactive power when we connect the two terminals of this battery to a circuit and close a switch to engage the chemicals inside of the battery to react against each other causing current to exit from out of the negative terminal which depletes the voltage difference between its two terminals unless it's a rotary generator in which the generator initiates an increased magnetic and mechanical resistance to whatever is attempting to rotate its shaft.

But the orientation of nomenclature remains intact, namely: the negative terminal of a voltage source is still emitting current of a negative polarity while its positive terminal has a positive polarity of voltage. By definition, this implies reactive power; not watts. This means that energy never exits the battery. Energy only enters the circuit, connected to this battery, if the circuit in question merely consumes

power without producing any.

The volts and amperes of every component within a circuit, and the polarity of their sign values, can be accounted for to satisfy a *segregated analysis* of a circuit's activity yielding volts/amperes (VA) or watts indicating the generation of reactive power or the consumption of real power at an electrical load.<sup>20</sup>

Gravity and the dielectric (electrostatic) force are one and the same force, for all intents and purposes, since both are torque-forces and they share the same equations of functionality – as exhibited, below. Their difference is that the torque-force of gravity travels through the empty dielectric medium of space (as well as through solid objects) while the torque-force of electrostatic charge travels through the dielectric mediums within the centers of capacitors and other dielectric mediums including empty space. And both share similar right-hand rules of structure which organizes their forces.

A gyroscope must lose weight whenever it spins<sup>21</sup> which implies that its gravitational constant must have become altered since we know its mass has not altered, nor has the mass of the Earth become altered. The fact that we can alter the gravitational constant of a mass by rotating it implies a parallelism with capacitive reactance.

Current, which begins its helical journey by traveling through a coiled mass of wire, is blocked by a dielectric wall sandwiched in the middle of two conductive plates of a capacitor resulting in an equivalency to the gyration of a spinning mass by producing a torque at right angles to the gyration<sup>22 23</sup> – and following the same right-hand rule utilized by magnetism following current,<sup>24</sup> because current must translate its helical motion into rotary motion within each plate of a capacitor. This blockage of current by a dielectric barrier produces a torque-force

---

20 “The Meaning of Unity in Energy Conversion Systems,” by James F. Murray, III and Aaron Murakami → <https://is.gd/zujaqu> = <https://www.amazon.com/dp/1650183658/>

21 “...gravity is neutralized by a gyroscopic mass...” → <https://is.gd/ibehob> = [https://youtu.be/XPUuF\\_dECVI?t=1700](https://youtu.be/XPUuF_dECVI?t=1700)

22 “Gyroscopic Precession” Veritasium → <https://is.gd/upexoq> = <https://youtu.be/ty9QSiVC2g0>

23 “8.01x – Lect 24 – Rolling Motion, Gyroscopes, VERY NON-INTUITIVE” lectures by Walter Lewin → <https://is.gd/veluba> = [https://youtu.be/XPUuF\\_dECVI](https://youtu.be/XPUuF_dECVI)

24 “Three Right Hand Rules of Electromagnetism” → <https://is.gd/ixiyus> = <https://www.arborsci.com/blogs/cool/three-right-hand-rules-of-electromagnetism>

analogous, and equivalent, to the capacitance of a dielectric medium. Likewise is the angular momentum of current (formed by its passage through a coil of wire) engaging inductive reactance. In both instances of a capacitor and a gyroscope, capacitive reactance of a rotating body is responsible for altering the presumed constancy of gravity (for all intents and purposes) due to the (analogously)<sup>25</sup> mathematical equivalency of both examples...

$$F = G \frac{m_1 \times m_2}{r^2} \quad \text{Newton's law of universal gravitation}^{26} \quad \text{\$4a}$$

Wherein...

F = force; a torque-force wherein all of the atomic (neutronic) energies are (normally) spinning in the same direction without recourse to making any attempt to alter their direction of spin orientation; any attempt at inverting the torque-force of either of these two masses, but not both, by reversing its spin-charge, would result in anti-gravity forces appearing between these two masses.

G = Gravitational constant<sup>27</sup>

m<sub>1</sub> = mass of one object

m<sub>2</sub> = mass of another object

r = distance between the centers of mass of m<sub>1</sub> and m<sub>2</sub>

Compare the equation, above, for Newton's law of universal gravitation in contrast with Coulomb's inverse-square law, below...<sup>28</sup>

---

25 "Inverse square law, Occurrences" → <https://is.gd/ipogox> = [https://en.wikipedia.org/wiki/Inverse-square\\_law#Occurrences](https://en.wikipedia.org/wiki/Inverse-square_law#Occurrences)

26 "Newton's law of universal gravitation" → <https://is.gd/onipoh> = [https://en.wikipedia.org/wiki/Newton%27s\\_law\\_of\\_universal\\_gravitation](https://en.wikipedia.org/wiki/Newton%27s_law_of_universal_gravitation)

27 "Gravitational constant" → <https://is.gd/iwewom> = [https://en.wikipedia.org/wiki/Gravitational\\_constant](https://en.wikipedia.org/wiki/Gravitational_constant)

28 "Coulomb's inverse-square law" → <https://is.gd/capobu> = [https://en.wikipedia.org/wiki/Coulomb%27s\\_law](https://en.wikipedia.org/wiki/Coulomb%27s_law)

$$F = k_e \frac{q_1 \times q_2}{r^2}$$

§4b

Wherein...

F = electrostatic (Coulomb) force; a torque-force in which all of the charges ( $q_n$ ) are spinning in the same direction.

$k_e$  = Coulomb's constant<sup>29</sup>  $\approx 8.988 \times 10^9 \text{ N}\cdot\text{m}^2\cdot\text{C}^{-2}$

N = Newton;<sup>30</sup> the force needed to accelerate one kilogram of mass at the rate of one meter per second squared in the direction of the applied force.<sup>31</sup>

m = meter

C = Coulomb;<sup>32</sup> unit of electric charge<sup>33</sup>

$q_1$  = signed magnitude of one dielectric (electrostatic) charge

$q_2$  = signed magnitude of another dielectric (electrostatic) charge

r = distance between the charges:  $q_1$  and  $q_2$

In both instances, the electrical dynamics of gravity is alterable by manmade artifice.

In other words, the so-called constancy of gravity is not always constant unless there is a constancy of geometrical forces of such long-standing duration that we delusionally take this presumed constancy of gravity for granted throughout all of our years of existing upon

---

29 "Coulomb constant" = <https://is.gd/urozud> = [https://en.wikipedia.org/wiki/Coulomb\\_constant](https://en.wikipedia.org/wiki/Coulomb_constant)

30 "Newton (unit)" → <https://is.gd/caveji> = [https://en.wikipedia.org/wiki/Newton\\_\(unit\)](https://en.wikipedia.org/wiki/Newton_(unit))

31 "Newton unit of measurement" = <https://is.gd/luzife> = <https://www.britannica.com/science/newton-unit-of-measurement>

32 "Coulomb" → <https://is.gd/okugal> = <https://en.wikipedia.org/wiki/Coulomb>

33 "Electric charge" → <https://is.gd/ibumug> = [https://en.wikipedia.org/wiki/Electric\\_charge](https://en.wikipedia.org/wiki/Electric_charge)

this planet Earth.

Reactive power changes all of this into a variable odyssey of manipulable factors.

We know that we can get energy out of falling water at a hydroelectric power plant. But if we can manipulate the constancy of gravity, then we can just as readily manipulate the potential energy of gravity and, hence, manipulate the actuality of energy in a circuit to the same degree of variation.

This is the power of leverage in which a small change, whenever properly situated, can produce a gigantic conclusion.

Electrical reactance gives us this leverage since electrical reactance is merely potential energy. It is not kinetic energy. That's why we do not measure opposing polarities of current and voltage in watts, but we measure them in terms of volts/amperes, because volts/amperes is not energy. Volts/amperes is merely a loose association of potential energies: the potential energy of volts and the potential energy of amperes lying outside of the domain of Ohm's Law. *{It's like two people in a room and they don't look at each other, nor acknowledge one another, much less talk to each other. Yet, we still have these two people occupying a room.}*

There is a known constancy regarding the inverse relationship between moment of inertia and angular velocity<sup>34</sup> in which an increase of moment of inertia decreases angular velocity and, conversely, a decrease of moment of inertia increases angular velocity in order to maintain (Conserve) the resulting product of their union, which is: their angular momentum, since there is no contribution of torque entering from outside, or from inside, of this isolated and static model of energy. This parallels a similar relationship under Ohm's Law in which real power is the product of voltage and current which requires a decrease of voltage should current increase and vice versa in order to maintain (ie, Conserve) the real power product of their multiplicative union (of voltage and current) manifesting as real power...

$$Power = Voltage \times Current$$

§2.1b

Yet, if we transpose this electrodynamic relationship into the domain of Mho's Law, then the outcome of the union of voltage with current is reserved, not conserved, for some future moment in time when the phase of voltage can be brought into alignment with the phase

---

<sup>34</sup> "Chapters 8 thru 9: Rotational Kinematics and Dynamics; Conservation of angular momentum" → <https://is.gd/jequto> = [http://mrtumnus.weebly.com/uploads/3/8/1/8/38188099/ch\\_8-9\\_notes\\_-\\_rotational\\_kinematics\\_and\\_dynamics.pdf](http://mrtumnus.weebly.com/uploads/3/8/1/8/38188099/ch_8-9_notes_-_rotational_kinematics_and_dynamics.pdf)

of current in order to be appreciated as real power under Ohm's Law and the Conservation of Energy. Until that moment (in time) is reached, this condition of the Reservation of Energy will continue to amass a greater momentum accumulating more and more reactive power, stored as momentum invisible to any practical consideration of measurable wattage due to its super-conductivity at room temperature.

Countless experiments have shown that additional torque need not exclusively enter into an energetic model from outside the model. Under Mho's Law, torque has the obligation to contribute its force from within the energetic model – not from outside itself...

$$\text{Conductivity} = \frac{\text{Current}}{\text{Voltage} \sqrt{-1}} \tag{§3.1b}$$

Thus, instead of the inversely proportional relationship between current and voltage under Ohm's Law maintaining (Conserving) the real power product of their multiplicative union, the conductivity of §3.1b, above, will cause the proportionality between current and voltage to vary directly, rather than inversely, under Mho's Law.

So, if voltage should rise due to the presence of resistance to motion (ie. Inertia), then current must also rise to maintain (Conserve) their conductivity resulting from their inversely multiplicative product, namely: the division of current by an imaginary (reactive) voltage...

$$\text{Conductivity} = \frac{\text{Current}}{\text{Voltage} \sqrt{-1}} = \text{Current} \times \text{Voltage}^{-1} \sqrt{-1}^{-1} \tag{§3.1bx}$$

...in which current possesses an imaginary component of imaginary (reactive) voltage...

$$\text{Current} = \frac{\text{Resistance}}{\text{Voltage} \sqrt{-1}} \tag{§3.2a}$$

...which has been extracted from out of conductivity serving as a mathematical construct...

$$\text{Conductivity} = \frac{\text{Resistance}}{-\text{Voltage}^2} = \frac{1}{\text{Voltage} \sqrt{-1}} \times \frac{\text{Resistance}}{\text{Voltage} \sqrt{-1}} = \frac{\text{Current}}{\text{Voltage} \sqrt{-1}} \tag{§3.1ab}$$

This additional torque will manifest as a direct relation between current and voltage (versus conductivity at equation §3.1b) in that any increase of either current or voltage will result in an increase of voltage or current. This will not allow any conservation of angular

momentum to occur. Instead, angular momentum (expressed as volts/amperes) will increase until either one of two conditions is reached...

1. Escalation of amplitude will eventually destroy the host-circuit prior to the achievement of infinite amplitude, or...
2. The acquisition of synchronicity between between the phase of voltage and the phase of current will halt this escalation of reactive power and reinstate its Conservation without Reservation.

This potential form of energy (conductivity under Mho's Law) will become actual energy (under the domain of Ohm's Law) when the orientation of its polarization becomes self-aligned, in which: its current and its voltage are either both positively oriented, or -else- both of them are negatively oriented. Then, and only then, will we have truly useful power, aka. energy. *{And the two people in our fictional room will stop ignoring each other!}*

#### BRIEF DESCRIPTION OF THE DRAWINGS

The accompanying drawings, which are incorporated in and constitute a part of this disclosure, illustrate various embodiments of the present disclosure. The drawings contain representations of various trademarks and copyrights owned by the Applicants. In addition, the drawings may contain other marks owned by third parties and are being used for illustrative purposes only. All rights to various trademarks and copyrights represented herein, except those belonging to their respective owners, are vested in and the property of the applicants. The applicants retain and reserve all rights in their trademarks and copyrights included herein, and grant permission to reproduce the material only in connection with reproduction of the granted patent and for no other purpose.

Furthermore, the drawings may contain text or captions that may explain certain embodiments of the present disclosure. This text is included for illustrative, non-limiting, explanatory purposes of certain embodiments detailed in the present disclosure.

FIG. 1 is a schematic of a battery and a ten Ohm resistor in accordance with some embodiments.

FIG. 2 is a graphical and numeric tabulation of reactive and real throughputs of the circuit in FIG. 1, in accordance with some embodiments.

FIG. 3 is the nodal voltage and a graphical mapping and a numeric tabulation of a segregated analysis of the circuit in FIG. 1, in

accordance with some embodiments.

FIG. 4 is a schematic of a battery and a one hundred milli Ohm resistor in accordance with some embodiments.

FIG. 5 is a graphical and numeric tabulation of reactive and real throughputs of the circuit in FIG. 4, in accordance with some embodiments.

FIG. 6 is the nodal voltage and a graphical mapping and a numeric tabulation of a segregated analysis of the circuit in FIG. 4, in accordance with some embodiments.

FIG. 7 is a schematic of a one micro Farad capacitor, precharged with one micro volt, and a resistor of ten Ohms, in accordance with some embodiments.

FIG. 8 is a graphical and numeric tabulation of reactive and real throughputs of the circuit in FIG. 7, in accordance with some embodiments.

FIG. 9 is the nodal voltage and a graphical mapping and a numeric tabulation of a segregated analysis of the circuit in FIG. 7, in accordance with some embodiments.

FIG. 10 is a schematic of a one micro Farad capacitor, precharged with one micro volt, and a resistor of one hundred milli Ohms, in accordance with some embodiments.

FIG. 11 is a graphical and numeric tabulation of reactive and real throughputs of the circuit in FIG. 7, in accordance with some embodiments.

FIG. 12 is the nodal voltage and a graphical mapping and a numeric tabulation of a segregated analysis of the circuit in FIG. 7, in accordance with some embodiments.

FIG. 13 is a schematic of a software macro, from the Micro-Cap electronic simulator, of one of several possible embodiments which is functionally equivalent to the observed behavior of a neon bulb, spark gap.

FIG. 14 is a schematic of an idealistic negative resistor and a capacitor with a battery intended to illustrate a runaway condition of the



unlimited generation of reactive power which, although not-realistic, is nonetheless the fundamental property of a spark gap and, thus, a perfect example of “free energy” for its lack of complexity, in accordance with some embodiments.

FIG. 15 are the nodal numbers for the schematic in FIG. 13, in accordance with some embodiments.

FIG. 16 is a highlight of only those electronic components of the circuit in FIG. 13 and FIG. 15 which are pertinent to the performance of a segregated analysis made upon this macro for a spark gap, in accordance with some embodiments.

FIG. 17 is Micro-Cap's assignments of polarity labels to the terminals of each component within the circuit of FIG. 13 and FIG. 15 and FIG. 16 wherein it is vital to identify, and segregate, for the purpose of making a discrete analysis upon this circuit to thoroughly assess its dynamics in order to conclusively determine from where is its energy coming from and towards where is this energy going and assessing what is the nature of each path of energy traversing through each component of electronics asking this question: is this pathway reactive power, or is this pathway real power, in accordance with some embodiments.

FIG. 18 is a simple circuit of nothing other than a single neon bulb, flanked by two resistors on either side, whose individual resistances are one milli Ohm, each, and terminated at both ends by a connection to ground, in accordance with some embodiments.

FIG. 19 is a graphical and numeric tabulation of reactive and real throughputs of the circuit in FIG. 19, in accordance with some embodiments.

FIG. 20 are the nodal voltages for the neon bulb, electronic macro used within the circuit for FIG. 18, demonstrating an OFF condition (non-arcing; humming with minimalist, ionic activity) for the neon bulb in FIG. 18, by virtue of node #10 (labeled: **Switchchk**) is exactly 10 nano volts – which is one of the test conditions for an OFF condition of the behavioral voltage source, **E2**, in accordance with some embodiments.

FIG. 21 is a segregated analysis of the circuit in FIG. 18 indicating a symmetrical condition of reactive power production equals real power consumption, in accordance with some embodiments.

Like FIG. 18, FIG. 22 is a simple circuit of nothing other than a single neon bulb, flanked by two resistors on either side, whose individual resistances have been increased to one kilo Ohm, each, and terminated at both ends by a connection to ground, in accordance with

some embodiments.

FIG. 23 is a graphical and numeric tabulation of reactive and real throughputs of the circuit in FIG. 22, in accordance with some embodiments.

FIG. 24 are the nodal voltages for the neon bulb, electronic macro used within the circuit for FIG. 22, demonstrating an OFF condition (non-arcing; humming with minimalist, ionic activity) for the neon bulb in FIG. 22, by virtue of node #10 (labeled: **Switchchk**) is exactly 10 nano volts, and terminated at both ends by a connection to ground, in accordance with some embodiments.

FIG. 25 is a segregated analysis of the circuit in FIG. 22, indicating a symmetrical condition of reactive power production equals real power consumption, in accordance with some embodiments.

FIG. 26 is a simple circuit of a neon bulb and a 100 volt battery, terminated on either end by a grounded node, and separated by three resistors of one kilo Ohm, each, which is the first instance for which a segregated analysis will be conducted – over the course of the following five figures, that seeks to demonstrate – once and for all – the futility of pursuing any segregated analysis due to the intrinsic nature of “free” energy which transcends accountability, in accordance with some embodiments.

FIG. 27 are a few of the throughputs of the circuit in FIG. 26 illustrating how a neon bulb, spark gap may, under certain conditions, commandeer its associated electronic components into becoming an oscillator and generator of reactive power despite a substantial throughput from a D/C voltage source of 100 volts which has failed to suppress the reactive growth of amplitude for this circuit's output. Located at the 4<sup>th</sup> row from the top, a pair of waves (the top wave is of current and the bottom wave is of voltage) of inverse phase relation (half an alternating cycle apart from each other – shifted in time) indicates a negative unity power factor which is the inherent definition of the generation of reactive power operating under the auspices of Mho's Law, and is in accordance with some embodiments.

FIG. 28 is a graphical and numeric tabulation of reactive and real throughputs of the circuit in FIG. 26, in accordance with some embodiments.

FIG. 29 are the nodal voltages for the neon bulb, electronic macro used within the circuit for FIG. 26, demonstrating an OFF condition (non-arcing; humming with minimalist, ionic activity) for the neon bulb in FIG. 22, by virtue of node #10 (labeled: **Switchchk**) is

exactly 10 nano volts, and terminated at both ends by a connection to ground, in accordance with some embodiments.

FIG. 30 is a partial segregated analysis of the circuit in FIG. 26, minus its neon bulb (for brevity), in accordance with some embodiments.

FIG. 31 is a complete segregated analysis of the circuit in FIG. 26, plus the segregated analysis of its neon bulb carried over from FIG. 30, demonstrating a disappearance of real power one thousand times greater than its appearance at the electrical load, in accordance with some embodiments.

FIG. 32 is the same as FIG. 26 except the 100V battery has been replaced with a one Farad capacitor, precharged with 100 volts, and all three resistors have been reduced from one kilo Ohm to one milli Ohm, in accordance with some embodiments.

FIG. 33 are a few throughputs of the circuit in FIG. 32 illustrating how a neon bulb, spark gap may, under certain conditions, commandeer its associated electronic components into becoming an escalating generator of reactive power despite the limited charge of 100 volts stored, nearby, within the one Farad capacitor, C1, in accordance with some embodiments.

FIG. 34 is a graphical and numeric tabulation of the reactive and real throughputs of almost all of the components within Micro-Cap's macro for a neon bulb, included within the circuit in FIG. 32, except for the throughput of the resistor, R4, in accordance with some embodiments.

FIG. 35 is a graphical and numeric tabulation of the reactive and real throughput for the resistor, R4, within Micro-Cap's macro for a neon bulb, included within the circuit of FIG. 32, in accordance with some embodiments.

FIG. 36 is a graphical and numeric tabulation of the reactive and real throughputs for all of the remaining components of the circuit within FIG. 32, apart from the neon bulb, in accordance with some embodiments.

FIG. 37 are the nodal voltages for the neon bulb, electronic macro used within the circuit of FIG. 32, demonstrating an ON condition (arcing) for the neon bulb in FIG. 32, in accordance with some embodiments.

FIG. 38 is a partial segregated analysis, performed manually, of the circuit in FIG. 32, minus its neon bulb (for brevity), in

accordance with some embodiments.

FIG. 39 is a complete segregated analysis, performed manually, of the circuit in FIG. 32, plus the manually calculated, segregated analysis of its neon bulb carried over from FIG. 38, in accordance with some embodiments.

FIG. 40 is an automated calculation of the segregated analysis of the subtotals of the load versus the spark gap of FIG. 32, in accordance with some embodiments. This automated subtotalling was calculated by Micro-Cap.

FIG. 41 is an automated calculation of the segregated analysis of the grand total of the circuit in FIG. 32, in accordance with some embodiments. This automated total was calculated by Micro-Cap.

FIG. 42 is the same circuit as FIG. 32 except that all three resistors have been increased from one milli Ohm to ten milli Ohms, in accordance with some embodiments.

FIG. 43 are a few throughputs of the circuit in FIG. 42 illustrating how a neon bulb, spark gap may, under certain conditions, commandeer its associated electronic components into becoming an escalating generator of reactive power despite the limited charge of 100 volts stored, nearby, within the one Farad capacitor, C1, in accordance with some embodiments.

FIG. 44 are the nodal voltages of the circuit in FIG. 42, minus the nodal voltages for its neon bulb, and minus any segregated analysis (for brevity), in accordance with some embodiments.

FIG. 45 is the same as FIG. 32 and FIG. 42 except that all three resistors have been increased to 100 milli Ohms, in accordance with some embodiments.

FIG. 46 are a few throughputs of the circuit in FIG. 45 illustrating how a neon bulb, spark gap may, under certain conditions, commandeer its associated electronic components into becoming an escalating generator of reactive power despite the limited charge of 100 volts stored, nearby, within the one Farad capacitor, C1, in accordance with some embodiments.

FIG. 47 are the nodal voltages of the circuit in FIG. 45, minus the nodal voltages for its neon bulb, and minus any segregated analysis (for brevity), in accordance with some embodiments.

FIG. 48 is the same as FIG. 32, FIG. 42 and FIG. 45 except that all three resistors have been increased to one Ohm, in accordance with some embodiments.

FIG. 49 are a few throughputs of the circuit in FIG. 48 illustrating how a neon bulb, spark gap may, under certain conditions, *fail to commander* its associated electronic components into becoming an escalating generator of reactive power, and revert -instead- to conventionally entropic results, due to the increased resistances having exceeded an amount of resistance which is slightly less than one Ohm, and due to the limited storage of voltage charged within the one Farad capacitor, C1, in accordance with some embodiments.

FIG. 50 are the nodal voltages of the circuit in FIG. 48, minus the nodal voltages for its neon bulb, and minus any segregated analysis (for brevity), in accordance with some embodiments.

FIG. 51 is a schematic of a hypothetical, electronic analog of the Ammann brothers' Atmospheric Generator, and of Nikola Tesla's TriMetal Generator, and the focus of this invention, in accordance with some embodiments.

FIG. 52 are the nodal voltages for FIG. 51, in accordance with some embodiments.

FIG. 53 is a graphical and numeric tabulation of the reactive and real throughput for the circuit's electrical loads within FIG. 51, apart from almost all of the components of Micro-Cap's macro for a neon bulb, except for node #10 for each of the four neon bulbs used in the circuit of FIG. 51, which indicates that one of these four neon bulbs (X4.10) is ON (arcing) and the three other neon bulbs (X1.10, X2.10 and X3.10) are OFF (humming with minimalist, ionic activity), in accordance with some embodiments.

FIG. 54 is a graphical and numeric tabulation of the reactive and real throughput for all of the components of Micro-Cap's macro for a neon bulb, plus node #10, for one of the four neon bulbs used in the circuit of FIG. 51. This neon bulb is labeled X1, within the schematic for the circuit in FIG. 51, and its throughput, in column #2 and #3, of 10 nano volts for its node #10, labeled: V(X1.10) (V) on line #12 in column #1, indicates that this neon bulb is OFF (not arcing, yet humming with a minimum of ionic activity), in accordance with some embodiments.

FIG. 55 is a graphical and numeric tabulation of the reactive and real throughput for all of the components of Micro-Cap's macro for a neon bulb, plus node #10, for one of the four neon bulbs used in the circuit of FIG. 51. This neon bulb is labeled X2, within the schematic

for the circuit in FIG. 51, and its throughput, in column #2 and #3, of 10 nano volts for its node #10, labeled: **V(X2.10) (V)** on line #12 in column #1, indicates that this neon bulb is OFF (not arcing, yet humming with a minimum of ionic activity), in accordance with some embodiments.

FIG. 56 is a graphical and numeric tabulation of the reactive and real throughput for all of the components of Micro-Cap's macro for a neon bulb, plus node #10, for one of the four neon bulbs used in the circuit of FIG. 51. This neon bulb is labeled **X3**, within the schematic for the circuit in FIG. 51, and its throughput, in column #2 and #3, of 10 nano volts for its node #10, labeled: **V(X3.10) (V)** on line #12 in column #1, indicates that this neon bulb is OFF (not arcing, yet humming with a minimum of ionic activity), in accordance with some embodiments.

FIG. 57 is a graphical and numeric tabulation of the reactive and real throughput for all of the components of Micro-Cap's macro for a neon bulb, plus node #10, for one of the four neon bulbs used in the circuit of FIG. 51. This neon bulb is labeled **X4**, within the schematic for the circuit in FIG. 51, and its throughput, in column #2 and #3, of 10 nano volts for its node #10, labeled: **V(X4.10) (V)** on line #12 in column #1, indicates that this neon bulb is OFF (not arcing, yet humming with a minimum of ionic activity), in accordance with some embodiments.

In FIG. 58, I asked the software to calculate a segregated analysis for all of the “load” electronic components minus the four neon bulbs, rather than doing this by hand, plus display the raw data for node #10, for all four neon bulbs used within the circuit for FIG. 51, to indicate whether or not any single neon bulb is ON or OFF. Taking this approach altered the outcome by turning ON one of the four neon bulbs, **X3**, which is associated with (and connected in parallel to) the two inductors, **L1** and **L2**, of the circuit in FIG. 51, in accordance with some embodiments.

Likewise, FIG. 59 is an automated, segregated analysis for one of the four neon bulbs, labeled: **X1** within FIG. 51, calculated by the Micro-Cap software. Also displayed is the raw data for node #10, for all four neon bulbs used within the circuit for FIG. 51, to indicate whether or not any single neon bulb is ON or OFF. Taking this approach turned OFF all four neon bulbs in FIG. 51, in accordance with some embodiments.

FIG. 60, is a segregated analysis for one of the four neon bulbs, labeled: **X2** within FIG. 51 and calculated by the Micro-Cap

software. Also displayed is the raw data for node #10, for all four neon bulbs used within the circuit for FIG. 51, to indicate whether or not any single neon bulb is ON or OFF. Taking this approach turned OFF all four neon bulbs in FIG. 51, in accordance with some embodiments.

FIG. 61, is a segregated analysis for one of the four neon bulbs, labeled: X3 within FIG. 51 and calculated by the Micro-Cap software. Also displayed is the raw data for node #10, for all four neon bulbs used within the circuit for FIG. 51, to indicate whether or not any single neon bulb is ON or OFF. Taking this approach turned OFF all four neon bulbs in FIG. 51, in accordance with some embodiments.

FIG. 62, is a segregated analysis for one of the four neon bulbs, labeled: X4 within FIG. 51 and calculated by the Micro-Cap software. Also displayed is the raw data for node #10, for all four neon bulbs used within the circuit for FIG. 51, to indicate whether or not any single neon bulb is ON or OFF. Taking this approach turned OFF all four neon bulbs in FIG. 51, in accordance with some embodiments.

FIG. 63 is a manually tabulated, grand total of a segregated analysis for the entire circuit in FIG. 51 utilizing FIG.58 through FIG. 62, inclusive, acting as a collection of automated individual outputs of voltage and current for each component, in accordance with some embodiments. This grand total indicates a slight excess of the generation of reactive power at the end of 214 seconds in the amount of – 346.8267 milli volts/ampere suggesting an overunity of (a gain over) the initial input of a precharged capacitor, C1 in FIG. 51, of one volt has been exceeded.

FIG. 64 is an automated, grand total of a segregated analysis for the entire circuit in FIG. 51 plus the raw data for node #10, for all four neon bulbs used within the circuit for FIG. 51, to indicate whether or not any single neon bulb is ON or OFF. Taking this approach affected the outcome by turning ON one of the four neon bulbs, X3, which is associated with (and connected in parallel to) the two inductors, L1 and L2, of the circuit in FIG. 51, in accordance with some embodiments.

This grand total (of FIG. 64) also (like FIG. 63) indicates a slight excess of energy, but this time the excess is of watts of the consumption of real power (rather than the production of volts/ampere of reactive power) at 210.36 seconds in the amount of approximately +1.621 milli watts, and spikes several times prior to that end moment. The most notable spike is at 160 seconds in the amount of +10.353 mega watts indicating a huge consumption of power, in accordance with some embodiments, which is *not* the source for the amplification of total power for the circuit in FIG. 51, and does not explain from where does this extra power come?

FIG. **65** is an improved version of FIG. **51** of a hypothetical, electronic analog of the Ammann brothers' Atmospheric Generator, and of Nikola Tesla's TriMetal Generator, in accordance with some embodiments.

FIG. **66** is a solution to a hypothetical problem which may plague technicians who attempt to build overunity circuits in general, or my invention in particular, in accordance with some embodiments.

FIG. **67** are the nodal voltages of the circuit in FIG. **65**, minus the nodal voltages for its four neon bulbs, and minus any segregated analysis (for brevity), in accordance with some embodiments.

FIG. **68** is a graphical display of the throughput for some of the components of the circuit within FIG. **65**, apart from the throughputs for the four neon bulbs (for brevity), in accordance with some embodiments.

FIG. **69** is a numeric tabulation and a graphical display of the throughputs for some of the components of the circuit within FIG. **65**, apart from the throughputs for the four neon bulbs (for brevity), in accordance with some embodiments.

FIG. **70** is the same as the circuit in FIG. **65**, except that this circuit is intended to give the circuit in FIG. **65** a means of shutting itself OFF by way of grounding both terminals of inductor, **L2**, in accordance with some embodiments.

FIG. **71** are the nodal voltages of FIG. **70**, in accordance with some embodiments.

FIG. **72** is a numeric and graphic display of the throughputs for some of the components of the circuit within FIG. **70**, apart from the throughputs for the four neon bulbs (for brevity), in accordance with some embodiments.

FIG. **73** is an assortment of various symbols used to represent spark gaps, in accordance with some embodiments. Some of these symbols on the right-hand side are very suggestive of diodes. One other on the left-hand side is suggestive of a capacitor. Both types of symbols are valid allusions to the multifunctional tasking capabilities of Micro-Cap's macro for a neon bulb, spark gap.

FIG. **74** is a simulation, in Paul Falstad's idealistic simulator, of a circuit of very high mutual inductance (far above unity), in accordance with some embodiments.

FIG. **75** and FIG. **76** are two more simulations, in Paul Falstad's idealistic simulator, of a circuit of very high mutual inductance (far



above unity), in accordance with some embodiments.

FIG. 77 is the original photograph of the Ammann brothers standing beside their EV conversion of 1921, in accordance with some embodiments.

FIG. 78 is a photo-scan of one of the two newspaper articles (that we know of) which documents the 1921 demonstration, performed by the Ammann brothers, using the original photograph of FIG. 77, in accordance with some embodiments.

FIG. 79 is a speculative conceptualization of a permanent magnet version of Nikola Tesla's TriMetal Generator, in accordance with some embodiments.

FIG. 80 is a speculative conceptualization of the flow of alternating current under Ohm's Law versus Mho's Law, in accordance with some embodiments.

#### DETAILED DESCRIPTIONS OF THE INVENTION

As a preliminary matter, it will readily be understood by one having ordinary skill in the relevant art that the present disclosure has broad utility and application. As should be understood, any embodiment may incorporate only one or a plurality of the above-disclosed aspects of the disclosure and may further incorporate only one or a plurality of the above-disclosed features. Furthermore, any embodiment discussed and identified as being “preferred” is considered to be part of a best mode contemplated for carrying out the embodiments of the present disclosure. Other embodiments also may be discussed for additional illustrative purposes in providing a full and enabling disclosure. Moreover, many embodiments, such as adaptations, variations, modifications, and equivalent arrangements, will be implicitly disclosed by the embodiments described herein and fall within the scope of the present disclosure.

Accordingly, while embodiments are described herein in detail in relation to one or more embodiments, it is to be understood that this disclosure is illustrative and exemplary of the present disclosure, and are made merely for the purposes of providing a full and enabling disclosure. The detailed disclosure herein of one or more embodiments is not intended, nor is to be construed, to limit the scope of patent protection afforded in any claim of a patent issuing here from, which scope is to be defined by the claims and the equivalents thereof. It is not intended that the scope of patent protection be defined by reading into any claim a limitation found herein that does not explicitly appear

in the claim itself.

Thus, for example, any sequence(s) and/or temporal order of steps of various processes or methods that are described herein are illustrative and not restrictive. Accordingly, it should be understood that, although steps of various processes or methods may be shown and described as being in a sequence or temporal order, the steps of any such processes or methods are not limited to being carried out in any particular sequence or order, absent an indication otherwise. Indeed, the steps in such processes or methods generally may be carried out in various different sequences and orders while still falling within the scope of the present invention. Accordingly, it is intended that the scope of patent protection is to be defined by the issued claim(s) rather than the description set forth herein.

Additionally, it is important to note that each term used herein refers to that which an ordinary artisan would understand such term to mean based on the contextual use of such term herein. To the extent that the meaning of a term used herein—as understood by the ordinary artisan based on the contextual use of such term—differs in any way from any particular dictionary definition of such term, it is intended that the meaning of the term as understood by the ordinary artisan should prevail.

Furthermore, it is important to note that, as used herein, “a” and “an” each generally denotes “at least one,” but does not exclude a plurality unless the contextual use dictates otherwise. When used herein to join a list of items, “or” denotes “at least one of the items,” but does not exclude a plurality of items of the list. Finally, when used herein to join a list of items, “and” denotes “all of the items of the list.”

The following detailed description refers to the accompanying drawings. Wherever possible, the same reference numbers are used in the drawings and the following description to refer to the same or similar elements. While many embodiments of the disclosure may be described, modifications, adaptations, and other implementations are possible. For example, substitutions, additions, or modifications may be made to the elements illustrated in the drawings, and the methods described herein may be modified by substituting, reordering, or adding stages to the disclosed methods. Accordingly, the following detailed description does not limit the disclosure. Instead, the proper scope of the disclosure is defined by the appended claims. The present disclosure contains headers. It should be understood that these headers are used as references and are not to be construed as limiting upon the subjected matter disclosed under the header.

The present disclosure includes many aspects and features. Moreover, while many aspects and features relate to, and are described in the context of the arrangement of electrical components surrounding, or immediately adjacent to, a spark gap, or to the restructuring of the

internals of spark gaps, embodiments of the present disclosure are not limited to use only in this context.

Overview:

FIG. 1 is a schematic for reviewing the dynamics of a simple D/C battery, voltage source in which the resistance flanking the right side of the battery is *greater than*  $1\Omega$ . This distinction, between greater than or less than a significant turning point of resistance (slightly less than  $1\Omega$  for this figure), will become more obvious when a spark gap is added in subsequent figures.

FIG. 2 is the output of the dielectric potential, current and power of FIG. 1. All of its output data conforms to a steady-state.

FIG. 3 is the nodal voltage of FIG. 1. The voltage of the grounded node is not displayed since it is assumed that anyone skilled in this art will recognize its value is always zero by convention. Also included is the status of the D/C battery, voltage source, and the status of its right-flanking resistor using the data from FIG. 2 with regards to whether or not each is a “generator of reactance” or else is an “electrical load” based on the polarization of sign values of the current and voltage of each component. This is in keeping with the polarity of sign convention of Berkeley SPICE electronic simulators, and the conventional nomenclature of polarity of sign for electrons versus the polarity of sign for the dielectric potential from the perspective of physics, and constitutes a segregated analysis for the purposes of reviewing the total power of each component, in combination with its status as a generator of reactance or its status as an electrical load, to perform an exhaustive survey of the sources of power versus the locations of the consumption of power and map these locations throughout the circuit for the purpose of summarizing the net (total) volts/amperes, or the total wattage, of the circuit – whichever the case may be. In this case, the total gain or loss of power is zero as indicated within this figure. In other words, there is no overunity of coefficient of performance. Instead, its coefficient of performance is 0%.

FIG. 3 exhibits the foundation for our blind acceptance of causality, and its analog of thermodynamics, in which the current of a reactive voltage source, ie. a battery, is flowing *away* from a greater voltage (located at the positive terminal of the battery since this terminal is greater in voltage than its negative terminal), while (in contrast) the current of a resistor is flowing *towards* its terminal of greater voltage indicating that this flow of current is consequential to the flow of current at the battery. So, the voltage difference of the resistor initially increases until it reaches a steady-state while the voltage difference of the battery initially decreases until its steady-state of zero difference of voltage between its two terminals is achieved.

Thus, thermodynamics always assumes a depletion of voltage at the source over time which further implies a non-“a priori” causality for all voltage sources. In other words, voltage sources are like bucket brigades in which nobody is the ultimate source for voltage. Yet, differences of voltage keep getting transferred from one “source” to the next in an endless chain of transference (the sun transfers moisture from the oceans to the mountains where it keeps flowing towards the sea, and the power grid recharges batteries using that hydroelectric power, and the consumer discharges batteries).

But as we will see further along in this discourse, Mho's Law changes all of this by converting some of the electronic components of a circuit into generators of reactive power while some other electronic components remain functioning as consumers of real power. Spark gaps help in this regard, but are not always necessary since there are many variations available for achieving this technique.

The dependency (which we've been collectively programmed into believing and accepting on blind faith) has been (now) broken which has made us dependent upon singular sources of voltage difference as our sole source for energy. For now on, our circuits can provide all of the voltage differences which we may need to empower our appliances to run in perpetuity on whatever scant voltage already exists in our immediate vicinity, such as: the micro volt resident within our atmosphere.

FIG. 3 also dispels the silly notion, although commonly held to be true, that Conservation of Energy is far-reaching and sacrosanct when, in reality, it is limited to the domain (jurisdiction) of symmetrical circuits which do not possess *any* reactivity, whatsoever, since they are under the auspices of Ohm's Law. This is contrary to the asymmetry of Mho's Law which succeeds at filling in the missing ingredient of knowledge which mathematically supports our belief in free energy.

FIG. 4 is a schematic for reviewing the dynamics of a simple D/C battery, voltage source in which the resistance flanking the right side of its battery is significantly *less than*  $1\Omega$ .

FIG. 5 is the output of the dielectric potential, current and power of FIG. 4. All of its output data conforms to a steady-state defined by Ohm's Law.

FIG. 6 is the nodal voltage and segregated analysis of FIG. 4 using the data from FIG. 5. Its coefficient of performance is 0% as indicated within this figure.

FIG. 7 has the same resistance as with FIG. 1 (namely, greater than  $1\Omega$ ), but the battery is replaced by a capacitor of  $1\mu\text{F}$  and  $3\Omega$  of equivalent series resistance to simulate a dielectric medium of tantalum or aluminum for usage in high voltage conditions (which I expect my invention will be subjected to). This capacitor is also precharged with a voltage of  $1\mu\text{V}$ .

It will become more obvious, further along in this presentation, why it is advantageous to replace a constant source of voltage (such as a battery) with a source of voltage in which its amp-hours are extremely limited (such as a precharged capacitor) if we refrain from suppressing the tendency for reactive power to surge (as transient overvoltages, overcurrents, etc) by *not* supplying reactive components, such as: capacitors and inductors, with a constant source of voltage rated at the full volts needed to power their load.

The clue resides within the inherent nature of a voltage *source* in which its equivalent function is as a *regulator* of voltage.

An additional clue resides within Mho's Law in which resistance is divided by the square of voltage (§3.1a)...

$$\text{Conductivity} = \frac{\text{Resistance}}{-\text{Voltage}^2} \tag{§3.1a}$$

This implies that the more resistance which a power supply has available to engage in, the more conductivity will result. It also implies that the less voltage we use for powering a circuit, then the greater is the conductivity of that circuit despite its lack of super-cooling to nearly absolute degrees, Kelvin, along with an inherent gain of power.

A precharged capacitor is used as an example of an electronic component which cannot regulate voltage as a steady-state (similar to spark gaps and dissimilar to batteries or rotary generators of electricity). Quite the contrary, being that capacitors are (by their very nature) reactive, regulation is the *last thing* they can accomplish and, thus, overunity is the *last thing* they might suppress if their precharged voltage is small enough to not get in the way of the initial onset of meager reactivity which must be fostered (ie. protected) against competitive sources of voltage (such as batteries) which might prohibit the growth of reactivity.

FIG. 8 is the output of the dielectric potential, current and power of FIG. 7. All of its output data conforms to the losses inherent within thermodynamics. This is not steady-state, because its parameters of power drop off at a hyperbolic rate using zero as its asymptotic limit.

FIG. 9 is the nodal voltage and segregated analysis of FIG. 7 using the data from FIG. 8. Its coefficient of performance is 0% as indicated within this figure.

FIG. 10 has the same resistance as FIG. 4 possesses (less than  $1\Omega$ ), but the battery is replaced by a capacitor of  $1\mu\text{F}$ , with  $3\Omega$  of equivalent series resistance, and it is precharged with a voltage of  $1\mu\text{V}$  to conform with the schematic of FIG. 7.

FIG. 11 is the output data of FIG. 10. Like FIG. 8, all of its output data conforms to the losses inherent within thermodynamics. This is not steady-state, because its parameters of power drop off at a hyperbolic rate using zero as its asymptotic limit.

FIG. 12 is the nodal voltage and segregated analysis of FIG. 10 using the data from FIG. 11. Its coefficient of performance is 0% as indicated within this figure.

Berkeley SPICE is an electronic simulator considered to be the standard of the engineering industry and a progenitor of a few examples of its commercial products, known as: LTSPICE and Micro-Cap (to name a few).

These electronic simulators define a “generator of reactance” as having an inverse polarity (a negation) of sign ascribed to its current as compared to its voltage and, thus, agrees with the view of physics cited at the beginning of this presentation.

Likewise, an “electrical load” is defined (by these simulators) as having a similar polarity of sign ascribed to both current and voltage arising from out of, or passing through, whichever electronic component possesses this characteristic.

Thus, a voltage source – such as a D/C battery possessing a difference of voltage between its two terminals – will have a positive voltage measured by an electronic simulator's virtual oscilloscope, and will also have a negative sign associated with its current to conform to an inverse polarization of sign value with respect to voltage versus current.

A non-reactive load, such as a resistor, will have both a positive current as well as a positive voltage, or else it will have a negative current and a negative voltage. But a reactive load, such as: a coil of wire, or a capacitor, or the capacitance between two coils which are magnetically coupled (as lumped inductors), are all three subject to electrical reactance which alters the character of this type of load to become a generator of entropy or a generator of negentropy. This latter condition of negentropy possesses a negative unity, power factor defined by its inversion (negation) of the polarity of signs associated with its current versus its voltage along with a separation of phase

between current and voltage by one-half cycle of alternating polarity.

Such is the case with Micro-Cap's macro for a spark gap in FIG. 13. It contains an artificially induced negative resistor of one Ohm of negative resistance at **R3**. This makes a spark gap a generator of reactance analogous to conventional generators, such as: rotary inductive generators at hydroelectric power plants, and solar panels on the rooftops above our homes, since a spark gap may generate reactive power when its resistance is overcome by an elevated voltage above its voltage threshold (of 90V in the case of neon bulbs). And this fulfills a spark gap has possessing the status of being capable of engendering negative resistance, ie. the inversion of voltage, to embody the principles of super-conductivity at room temperature and encourage overunity of the coefficient of performance due to Mho's Law.

Negative resistance (the inversion of the phase of alternating voltage relative to the phase of the alternation of current) will generate reactance under ideal conditions if: A) it is located alongside a reactive component, such as: an ideal capacitor<sup>35</sup> in FIG. 14, or B) it is located alongside an ideal inductor (replacing the ideal capacitor in FIG. 14). No generation of reactance will result if a negative resistor is placed alongside another resistive load, such as: a resistance of positive value (replacing the capacitor in FIG. 14 with a positively signed resistor). *{FIG. 14 uses Paul Falstad's idealistic simulator<sup>36</sup> and is merely intended for the purpose of illustrating this hypothetical discussion of negative resistance in general. I prefer to craft my overunity circuits using a more realistic simulator, such as: Micro-Cap, since it is more challenging and more practical. But, sometimes, an idealistic simulator is more suitable to illustrate a generalization of theory.}*

Micro-Cap's macro for a neon bulb, spark gap satisfies this criterion since it contains an inductor, **L1**, and two capacitors, **C1** and **C2**, alongside negative resistor, **R3**, in FIG. 13.

The condition of the inversion (negation) of voltage, relative to current within an alternating cycle, does not need to raise the amplitude of its circuit's output dependent upon the formation of an arc within a spark gap. Mho's Law makes it possible for the restructuring of the causal relationship we have grown accustomed to regarding generators and consumers regardless of arc formation within a spark gap. In other words, the formation of an arc within a spark gap is not required for the amplification of output to manifest. Nor is the presence of a

---

35 Negative Resistance → <https://is.gd/negres> = <http://vinyasi.info/ne?startCircuit=negresist.txt>

36 Electronic Simulator → <http://falstad.com/circuit/>

spark gap required to invoke Mho's Law. Once spark gaps are fully understood, by studying macros of their behavioral characteristics such as the macro devised by Micro-Cap's electronic simulator, it becomes possible to mimic a spark gap's behavior without its presence using novel methods as are evident within FIG. 68.

Power is not a *required* cost for sustaining the overunity of this methodology since merely a minimum *voltage difference* will sustain it. The concurrence of current arising from out of a voltage source intended to power overunity is merely intended to support Ohm's Law and has nothing to do with sustaining the benefits of this methodology.

In other words, why waste any more current (and its consequential expenditure of power) than is needed to benefit from this invention if all that is *really* needed is to manifest Mho's Law supported by Ohm's Law?

Hence, it is possible to do away with a voltage source, such as: a battery, and use the ambient energy of the environment immediately surrounding a circuit powered by a capacitor which is precharged by this environmental dosage of energy. This is what my invention will demonstrate: that the jurisdiction of the Conservation of Energy can be transcended (not violated) to support the runaway amplified outputs of inductive loads.

FIG. 15 is the same schematic as FIG. 13 with the addition of nodal numbers for ease of discussion.

FIG. 13 and FIG. 15 is a software, macro circuit designed to emulate the behavior of a spark gap. Since a spark gap has no internal circuitry of its own, any electronic emulation of the internal dynamics of a spark gap is purely mathematical predicated upon more than a century of technical expertise acquired by those who are skilled in this art.

Yet, it could be said of spark gaps, that this emulation *most certainly occurs as electrically mapped out* within the dynamics of the atomic composition inside of a spark gap.

Thus, it becomes possible to speculate (from these simulations of a neon bulb) on what might happen if a circuit were to emulate the internal construction of neon bulbs in particular, and spark gaps in general, to augment the circuit's ability to restructure their behavior transcendental to common sense.

The software engineers who designed Micro-Cap's macro for a neon bulb, spark gap have figured out how to disassemble electricity



into its component elements: of magnetism, dielectricity and time, and then reassemble them into a format which closely resembles the behavior of a spark gap. This process of the disassembly of electricity makes it possible to modify the output of its hosting circuit.

Micro-Cap's macro for a spark gap has only one inductor, **L1**, simulating both electrodes of a neon bulb.

How can this be? Is this realistic? Yes!

If we assume that what is being simulated is not a single electrode, but the surface of both electrodes, and the single inductor, **L1**, simulates the junction between the metallic electrode material of both electrodes and the gaseous gap between them within a real world spark gap, then this singular function is a buffer between the conductivity of an electrode versus the reactivity of the neon gas, making this singular inductivity functionally equivalent to both electrodes of an actual neon bulb and the gas between them.

Also significant is the fact that the negative resistance of **R3** is placed immediately adjacent to this singular inductor, of **L1**, and in parallel with a single resistor, at **R1**, and it is this threesome that defines the functionality of this junction on the surface of all spark gap electrodes.

This location is where the magic of electrical synthesis occurs at the surface of an electrode, adjacent to a potentially arcing plasma. This is also where the magic of our Solar furnace transduces the reactive power, generated at its central “dark star” deep within the interior of its hollow surface, into the heat and light which enlivens our planetary biosphere. This junction is between [www.TheSurfaceOfTheSun.com](http://www.TheSurfaceOfTheSun.com) and its atmospheric plasma of silicon and neon immediately above a solid, planetary surface of calcium ferrite. This calcium ferrite acts as a magnetic coupling between the inner dark star (unlit neon bulb) and the lit neon/silicon bulb at the outer photosphere of our Sun which serves to electrically isolate the inner dark star from the outer, active photospheric star material of neon and silicon plasma.

FIG. 16 is a schematic of Micro-Cap's spark gap macro in which I have drawn a square boundary around the area of this macro that disassembles electricity and reassembles it and can sometimes amplify it where ever there are inductive loads outside of itself while sometimes making it disappear inside of itself with no accountability transcending logical causality. Everything else outside of this bounded square, such as: Micro-Cap's use of behavioral voltage sources, merely determines when to turn ON the sparking function of this neon bulb

and when to turn it OFF and also determines how much current to manifest relative to various voltage differences. So, if somewhere within this circuit macro is to be sought some area for making modifications and improvements of net output, then it is within the bounded domain (so enclosed) wherein we will discover our goal of the buildup of dielectric potential despite no overunity, but an underunity, of the total coefficient of performance for this device to *appear to exceed* conventional standards of excellence if we refuse to perform a thorough segregated analysis of whatever is transpiring inside of this modified spark gap.

HINT... Energy may disappear at a rate which is far greater than its appearance, or appear at a rate far greater than its disappearance, *apparently* debasing our limited awareness of thermodynamics and, yet, create an abundance of energy at the load (for our appliances) far greater than the energy it takes to empower the circuits of this invention to perform this benefit.

It could be possible that an explanation for this anomaly may be acquired by performing several segregated analyses (over a period of time) on one of these types of circuits, enumerated herein, because it may be possible that an over-abundance of the consumption of power may be explained by the over-abundance of the production of energy at a later point in time and vice versa?

Or it may be that Mho's Law style of super-conductance at room temperature may be all that is required to explain the phenomenal behaviors of my circuit examples? Or, some combination of these two explanations?

My intention for this discussion is to merely suggest certain phenomena without necessarily provide all of their answers.

FIG. 17 is a sectional slice of this bounded domain of FIG. 16 exhibiting the labels which Micro-Cap uses which will help us analyze the output of any circuit which uses this spark gap. Thus, whenever an output gives us a current and a voltage of either a positive or a negative polarity of sign, we'll be able to make a determination as to whether or not any specific component is behaving as a generator or as a load by comparing the sign of the voltage versus the sign of the current for that component's output. *{This has already been pursued in FIG. 3, 6, 9 and 12.}* Furthermore, we'll be able to map out the flow of current and the orientation of voltages to make a determination as to how this macro is disassembling and reassembling electricity as a reactant method of manipulating the amplitude of either the production or the consumption of electricity. It's a very fruitful area ripe for learning about the internal dynamics of spark gaps.

FIG. 18 is a schematic of a normal spark gap, in the format of a neon bulb, in which the resistances flanking both sides of the spark

gap are  $1\text{m}\Omega$ .

FIG. 19 is the output of the dielectric potential, current and power of FIG. 18. All of its output data conforms to a non-steady-state of thermodynamic dissipation.

FIG. 20 displays the nodal voltages generated by Micro-Cap of the spark gap inside of FIG. 18.

FIG. 21 displays the nodal voltages of FIG. 18 generated by Micro-Cap and a segregated analysis of FIG. 18 and the spark gap inside of it using the data from FIG. 19 to derive this analysis. It includes a mapping of current flow and voltage orientation determined by the output of this simple circuit. It demonstrates the symmetrical equivalence of the dissipation of real power versus the generation of reactive power and, thus, favors the Conservation of Energy under Ohm's Law over the asymmetry of admittance under Mho's Law. This mapping demonstrates the variety of responses available to each component, within the context of this type of analysis, in which each component may either generate reactance or consume electricity. But it doesn't stop here...

The generation of reactance is an endothermic behavior if there are no extenuating circumstances to complicate matters any further than this, such as: the back EMF of coils inside of a rotary generator. And the consumption of electricity is an exothermic behavior. These facts are commonsense to every physicist.

In other words, we don't always need to super-cool a circuit's components to achieve super-conductance. The alternative is also possible in which we may super-conduct a circuit's components in order to achieve its super-cooling.

But these thermal distinctions are trivial since they are merely the consequential behaviors of electronic components in particular and electrical behavior in general. These thermal factors are not causative; they do not define the distinctions between the generation versus the consumption of power. Only the polarity relationships of the sign values of voltage relative to the sign values of current defines the distinction between reactive power generation and real power consumption.

Thus, thermodynamics is a trivial affair which should be relegated to the electrical technician who has to take environmental effects into account when crafting a real-world build of a theoretical device. Thermodynamics should not be a serious concern of determining whether or not an electronic device will support a load versus drain a source. Only polarity of sign value of voltage and amperage should be

anyone's concern for making a determination as to whether or not an electronic device will support a load versus drain a source.

It is a trivial matter whether or not an electronic component generates or consumes power unless we're concerning ourselves with its consumption of heat – if it is a generator of reactance, or its generation of heat – if it is a consumer of electricity. This obsession with thermodynamics is just that: an obsession with the movement of calories from, or towards, the environment surrounding an electronic device and has nothing to do with the strict mathematics which models the behavior of electrical theory operating in the real world.

As far as many electronic simulators are concerned, their viewpoint pays strict attention to the details of mathematical modeling and simulators are oblivious to whatever physical interaction a circuit has with its environment (as if the environment does not exist) unless we program the simulator to include more parameters emulating the environment immediately surrounding electronic components, yet, unaffiliated with the behavior of these components.

When analyzing a circuit's behavior to determine whether or not it is behaving as an overall generator of reactive power or behaving as an overall consumer of real power, the movement of calories is a side-effect and possesses no serious consequence to any endeavor to determine whether or not an electronic device has an overunity coefficient of performance.

There are a lot of trivial matters when concerning ourselves with complex phenomena. And this endeavor of mine, to promote a greater awareness of so-called: “free energy,” is no exception to this rule of thumb.

Hence, we have our priorities backwards putting caloric movement as an “a priori” focus of our attention span which is already limited enough as it is in its lack of tolerance for dwelling on the topic of so-called: “free energy” to waste this limited attention span on this trivial concern of caloric movement as if this is what defines energy when, in fact, it is merely a side-effect and not a causative agent to energy's production or consumption at all.

What's worse, is that “a priori” truth arises from mathematics while “a posteriori” truth arises from experience by the Latin definition of these Roman terms. Caloric analyses of inventions and devices is, thus, “a posteriori” putting it into an inferior position relative to any segregated analysis of the mathematics behind the polarity of sign value occurring within each and every electronic component in the context of the behavior of that circuit. So, our language already tells us that we have the wrong priorities claiming physics is the correct authority for

any discussion of this matter overriding our linguistic common sense! But do we pay attention to this linguistic fact – which is hidden in plain sight in front of our collective noses? No! We just go along with what we are told to believe and never question the authenticity of our beliefs.

This lack of ability for us to think in a logical manner belies our collective stupidity, or our propensity for sloth, or both. But most importantly, it belies our fear of change as if growth of intelligence is something to be afraid of!

Polarity of sign value is the only correct procedure for the segregated analysis of a circuit's production of reactance and/or consumption of real power and caloric analysis plays no significant role, whatsoever, in making this determination. Thus, thermodynamics can be ignored whenever studying this topic of “freely available reactive power” renamed into the colloquialism of: “free energy.”

One more aside...

The difference between a con artist and a salesman is that a con artist fails to deliver on his promised sale while a salesman fulfills his promise to deliver a sale. So, a con artist advertises a potential sale while a salesman advertises an actual sale that may take place should the prospective customer decide to follow through on the proposition for a sale.

So...

Do I deliver anything, or do I merely deliver empty promises?

That will be for the electrical technician to decide if, and when, he/she builds this device. Neither you, nor I, can make this determination without assistance from an electrical technician to manifest these simulations and discover whether they are pipe dreams or opportunities that we have overlooked.

But at least, my promises are logical due to their mathematical rigor.

FIG. **22** is similar to FIG. **18** except that the two resistors on either side of the spark gap have been raised to  $1\text{k}\Omega$  of resistance.

FIG. **23** is the output of the dielectric potential, current and power of FIG. **21**. All of its output data conforms to a non-steady-state of thermodynamic dissipation.

FIG. 24 are the nodal voltages generated by Micro-Cap of the spark gap inside of FIG. 22.

FIG. 25 are the nodal voltages of FIG. 22 generated by Micro-Cap and a segregated analysis of FIG. 22 and the spark gap inside of it using the data from FIG. 23 to derive the analysis. It includes a mapping of current flow and voltage orientation determined by the output of this simple circuit. It demonstrates the symmetrical equivalence of the dissipation of real power versus the generation of reactive power and, thus, favors the Conservation of Energy under Ohm's Law over the asymmetry of admittance under Mho's Law.

Referring to FIG. 21 and FIG. 25, nothing interesting is happening, here, from the perspective of overunity, so we'll use these figures as a reference for the default condition of a neon bulb, spark gap, which is: that they represent the underunity of their coefficient of performance. Underunity, ie. the self-damping of a wave, is a common misconception in the belief that it is the *only* possible type of wave and is, thus by misguided inference, the only explanation for the behavior of all waves.

Yet, there is something peculiar occurring at FIG. 25. The voltage at V1 within the spark gap is zero voltage, yet its current is not zero. Under normal conditions, we'd interpret this as being zero watts as well as zero voltage. But this is not what is happening here.

What is happening, is that some unknown voltage is simultaneously bipolarized causing the net voltage difference to be zero. It doesn't mean that there is no voltage, here, at V1. It just means that an undetermined voltage is bidirectionally polarized making it impossible for us to make a determination as to its absolute value and impossible to determine its orientation due to a conflicting possibility of simultaneous oppositional value of sign. It could be an infinite absolute value of voltage for all we know, or an infinitesimally small absolute value of voltage. We'll never know. But that doesn't mean that it does not exist. We merely can't make a determination one way or another.

The impact is that we don't know whether this is a generator of reactance, or an electrical load, even though it generates zero watts, because its current and its voltage are not in *definitive* alignment. Had they been aligned, that would have qualified this component as an electrical load. Anything else, by extended definition, is a generator of volts/amperes.

Notice how I said, a “generator of [reactant] volts/amperes” rather than saying, a “generator of electricity”? This is to distinguish the fact that this cannot be a generator of watts, nor of real power, owing to the premise of physics stated at the beginning of this presentation

regarding sign convention of an electron.

Effectively speaking, this component (of **X1.V1** in FIG. **25**) is manifesting magnetism without any dielectricity being simultaneously manifested. So, this is a mere fragment of electricity arising here.

It would be hard to call this reactive power in the conventional sense. It would be just as foolish to call this real power so long as its voltage remains zero. Yet, it has more in common with reactive power than it has in common with real power due to this fragmentation of exclusively manifesting magnetism in the format of current devoid of dielectric potential.

So, reactive power is the closest analogy (even though it has a 50/50 chance of being an electrical load) and will have to suffice until we upgrade our physics to accommodate this anomaly.

FIG. **26** through FIG. **31** is a circuit schematic, its nodal voltages, and RMS outputs used as raw data for calculating the segregated analysis (included, herein) which exhibits all of the characteristics of a constant voltage source, ie. the 100V battery, supplying voltage regulation to the output keeping it rock-steady, on average, as an oscillating set of waves.

The segregated analysis in FIG. **31** of the circuit in FIG. **26** begins to exhibit more real power being consumed than the reactive power which is produced. All of the prior circuit examples leading up to this one exhibited an exact mathematical equivalency between production and consumption which ultimately zeroed out. Herein is where we'll begin to see examples of the consumption exceeding production. And later on, we'll see examples of production exceeding consumption. This suggests a disassociation between the two in which consumption fails to neutralize production as an oppositely signed counter-magnitude which the Conservation of Energy requires of circuits to comply with thermodynamics.

This is a nightmare for physicists who, like bankers and certified public accountants, prefer all of their assets (production) to be the exact duplicate (in absolute value) of their liabilities (consumption) but of opposite polarity of sign value such that all positively signed denominations cancel all negatively signed denominations resulting in a total of zero net gain or zero net loss. That way, bankers and accountants can sleep peacefully at night without any nightmares. This is why free energy is against public policy which seeks to control everything: money, energy, etc.

According to the segregated analysis of FIG. **31**, the coefficient of performance for this circuit will be slightly more than  $\frac{3}{4}$  of  $1/10^{\text{th}}$  of 1%, or more precisely:  $1 - 0.9992235 = 0.0007765$  making this an *extremely inefficient* circuit. Nor does this analysis explain where did nearly three and a half kilowatts, over 99.9% of its energy, come from which disappeared at diode, **D1**, inside of the spark gap macro?

In other words, Conservation of Energy and Ohm's Law does not explain this failure of accountability which is inherent in this peculiar example of a non-overunity circuit simulation failing to make any thermodynamic sense to the commonplace engineering perspective which is schooled in thinking in a normal manner of logically deductive reasoning. Yet, Mho's Law explains this behavior, and explains it very well, without violating *any* law of physics.

This is why I don't think we should be calling anything a producer of reactance or a consumer of energy. It may work in *some* examples of conventional circuitry, it may work in *most* examples of acceptable circuitry, but it may not explain all circuitry.

In fact, we have taken figures of speech and converted them into venerable laws of physics by simply repeating these figures of speech so often that we have forgotten their idiomatic roots of conventional speech patterns.

But, as has often been quoted by various sources as saying something similar to the effect of: “Repeat a lie often enough by enough people and make it a big enough lie, and it will (eventually) be accepted as the truth.”<sup>37</sup>

It is interesting to note that this quote is an abusive perversion of a well-known fact of yoga practice in which: “if the mantra is repeated often enough, it becomes the truth (enlightenment becomes an all-time reality for the yoga practitioner) despite all odds set against the yogi to achieve this goal. It is not necessary for the aspiring yogi, nor is it relevant, to dwell on any meaning attributed to the mantra since meaning is not relevant to the practice of yoga and will get in the way of achieving the goal of yoga which is to transcend all meaning and transcend all thought to get to the source of thought which is beyond the realm of the thinking mind and without becoming a mindless idiot in the pursuit of this lofty goal called: “samadhi” in the Sanskrit, namely: awareness without anything to be aware of.

Also, if enough people practice meditation on a regular basis, then world peace is the result as has already been thoroughly

---

37 Famous Sayings: #56 – 'Repeat a Lie Often Enough...' → <https://is.gd/vuvezo> = <https://shmaltzandmenudo.wordpress.com/2017/04/07/famous-sayings-56-repeat-a-lie-often-enough/>



documented by the Transcendental Meditation movement operating under the auspices of its founder, Maharishi Mahesh Yogi.<sup>38</sup>

The import of this, that the silent repetition of a meaningless string of phonemes can produce world peace by enlightening its practitioners, is a very large aspiration.

Thus, all of the criteria of the quote, first cited up-above regarding lies (lots of people frequently repeating a big idea which has yet to become the truth), also holds true for yoga as much as it holds true for achieving world peace.

A dream is a mere placebo until it develops into reality. The force of evolution fills in the gaps between a dream and its actualization.

This holds true for physics and electrical engineering as well as for goals. ;-)

All energy does not equal all mass times the speed of light squared probably due to the energy in question is not totally related (nor relevant) to electrical energy, but is only relevant to nuclear energy.

The only energy relevant to electrical energy are the valence electron volts of the atoms of the materials of construction in a circuit, because various electrons can choose to participate, or not participate, in the electrodynamics of a circuit's behavior at any point in time making it impossible, sometimes, to account for everything.

All we look at is the energy entering and exiting a circuit while ignoring the potential energy congregating inside of every circuit in the form of whatever valence electrons are not participating in its electrodynamic behavior. At any, and every, point in time, various valence electrons may choose to “sit it out” versus “engage in the game” (so-to-speak) which can, and does, skew the results giving the false impression (to us witnessing all of this from our macroscopically blurred {distant} vantage point) that either our accounting is wrong or (else) that physics has been violated.

It's our own fault for misinterpreting the data and drawing false conclusions, thereby.

You want to know what I think?

I think that electrical reactance engages in a sloppy form of communication among the various components of a circuit in which, like

---

38 The TM Technique → <http://tm.org/>

the childhood game of “telephone,” not all of the information gets safely transferred from one component to another. Instead, some of the information gets “lost in translation” (so-to-speak) causing these anomalies which cannot be accounted for by the utilization of Ohm's Law, yet is accounted for under Mho's Law.

It's as if two or more gears in a transmission system have a considerable amount of “slippage” causing a loss, or gain, of energy and an inability to account for all of the energy in the system if we are blind to this slippage (occurring in front of our eyes) and also blind to how many gears we may be overlooking and what are the size of these “invisible” gears of valence electrons? Or, maybe the non-valence electrons underneath the valence electrons are somehow getting involved to facilitate this slippage of information among the valence electrons?

These invisible gears are the valence electrons, or non-valence electrons, which we are not accounting for since they “sit out” any participation in a physical circuit's dynamics most of the time causing us to take them for granted most of the time. Then, when they *do* choose to participate, we're shocked and confused assuming that some law which governs our stable life has been violated when, in fact, nothing has been violated. In short, we act as if we are sleep-walking and confident that we are keeping track of everything when, in fact, we are asleep at the “wheel of our life” and don't know it.

Worst of all.... We refuse to wake up! Instead, we claim to (already) be awake while simultaneously denying these anomalies which serve as our wake-up call to total reality – not merely the reality we wish to give credit for, but *all* of electrodynamic reality.

Tesla performed tolerance tests of the materials of construction, such as upon: copper wires, the dielectric plates of capacitors, etc, to see if and when would these materials break down. He exploded copper wires into nano-fine particles of copper dust, he punctured holes through the dielectric plates of capacitors, and other sundry experiments to see what are the physical limits of valence charges which are less than the non-limit of infinity which exists as the theoretical boundary condition for the absolute magnitude of free energy. This physical limit is the only limit we should be worrying about. This limit is governed by the valence charge which binds matter together into a conglomeration of solidity which we take for granted on the one hand, and also hold the continuity of this solidity to be (somehow) sacred as well. Yet, it is this valence charge of the materials of construction of our circuits which is the *only* source for all of our energy unless someone should prove the existence of an Aether.

Tesla assumed nothing. He tested everything. He was obsessed with efficiency and with the total picture of electrodynamic reality.

That's why he's a genius. Because he's willing to do his *own* homework and not take anyone's description of reality on blind-faith for whatever we've been taught to believe in.

Again...to repeat myself...

Where is the justice in Christ performing a miracle of multiplying a few loaves of bread and a few pieces of fish into enough food to feed a multitude of people?

Where is the American Way of Commerce when He turned worthless water into valuable wine and refused to charge a fee for His kind and brotherly service?

This is what I mean by “slippage” among gears which are loosely enmeshed. There is no direct causal relationship that would make any commercial sense, nor any moral sense, to justify giving away a substantial quantity of valuable merchandise for free! Nor, stealing valuable merchandise without due compensation made towards its owners.

Yet, that's what “free energy” implies! All the customer has to supply is the *need* for a product or service and the end result is guaranteed provided the customer no longer allows himself, or herself, to waste these gifts in senseless pursuits, as Christ admonishes the beneficiary to... “Go and sin no more.” This is a normal life. Anything else less than this is subnormal, substandard and subhuman.

The whole point behind physics is the presumption that accountability is all-encompassing and this obsession of physics is a misrepresentation under certain circumstances as the preceding analysis in FIG. **31** of a simple, non-modified spark gap has demonstrated.

So, why do a segregated analysis of free energy circuits if all inputs and outputs cannot be linked in a logically causal set of relationships? Why go to any trouble to convince conventional perspectives when conventional perspectives will be superseded by Mho's Law which transcends the strict logic of accountability?

I guess, it would be to point out the flaw of assuming that we can, or should, account for everything?

I set out pursuing this discussion with the belief that a segregated analysis would defy irrational non-acceptance of overunity circuits

in general and my invention in particular. To my dismay, the circuit of FIG. 26 and its segregated analysis in FIG. 31 defies Sir Isaac Newton's Second Law of Motion which states that, “the rate of change of momentum of a body over time is directly proportional to the force applied, and occurs in the same direction as the applied force.”<sup>39</sup> The circuit of FIG. 26 *defies* Newton's second law of motion, because FIG. 31 exhibits no causal link between the source of voltage at the 100V battery of that circuit and the resultant wattages and volts/amperes occurring within the spark gap analyzed in FIG. 31.

Despite this caveat undermining the conventional wisdom of physics, we get some hints as to what is going on within the spark gap (courtesy of FIG. 31) which spiritualizes an otherwise entrenched materialism engulfing physics by converting materialism into immaterialism.

Diode, **D1**, within Micro-Cap's spark gap macro is consuming a tremendous amount of energy (nearly 3½ kilowatts) in contrast to the battery, **V1**, which is producing reactance at a far smaller rate of nearly 3 volts/amperes. These are the only components worth focusing our attention on since these are the only components with the largest consumption of energy and production of reactance occurring anywhere throughout this circuit. Yet, their absolute magnitudes do not equal each other. Energy simply disappears without ever having appeared in the first place (as reactance). The ratio of this disappearance is vastly greater than its appearance by a factor of one thousand to one (1.28783k to 1) which is the mathematical reciprocal (multiplicative inverse) of  $\frac{3}{4}$  of one-tenth of one percent ( $1 \div 0.0007765$ ).

In addition to FIG. 31, variations of this anomaly will shortly repeat itself (at FIG. 41 and FIG. 58 through FIG. 63, inclusive, and FIG. 67, and FIG. 74 and FIG. 75, below) when I present a segregated analysis of another simple spark gap circuit followed by various versions of my invention.

This defiance of Newton's second law suggests an intriguing cosmology in that all of creation is the manifestation of “cycles of repetition” wherein the cycles do not possess an “a priori” first cause, nor do they possess an ultimate conclusion. Instead, each cycle is part of an endless progression of repetitions whose causal linkages only exist in between any two cycles of repetition. This relationship between any two adjacent temporal cycles is the source for our scientific laws and mathematical relationships, but is restricted to this limited domain

---

<sup>39</sup> “Newton's laws of motion; Newton's second law” → <https://is.gd/beganu> = [https://en.wikipedia.org/wiki/Newton's\\_laws\\_of\\_motion#Newton's\\_second\\_law](https://en.wikipedia.org/wiki/Newton's_laws_of_motion#Newton's_second_law)

of temporal jurisdiction and does not (cannot) supersede it.

Causality and its resultants only applies to the interconnecting relationship between two successive cycles of repetitious activity. This limited domain cannot transcend this limited jurisdiction and become applicable to all of time. Any scientific attempt on our part to transcend this limited domain is overtaken by amorphous bliss. And if we can become so familiar with this bliss such that it is always in the background of our awareness, even upon the event we know of as our own mortal death, then we have achieved enlightenment.

A circuit can get a momentary glimpse of bliss whenever it transcends causality, such as: within the context of Mho's Law operating within a spark gap or within an analogous circuit devoid of any spark gap, because it is during this transcendence of causality in which bliss is no longer overshadowed by the rigors of causality which we know to be scientifically and karmically validated by our vast history of expertise on this subject of both material and spiritual causalities.

It is this transcendence of causality which accounts for “free energy” by *not* accounting for its segregated analysis, but by *preventing* any possibility for a segregated analysis to make any logical sense.

FIG. 32 is a schematic of a simple circuit involving an unmodified, neon bulb, spark gap, three resistors of  $1\text{m}\Omega$ , each – resistors: **R1**, **R2** and **R3**, plus a one Farad capacitor precharged with 100 volts.

FIG. 33 is a graphical display of a few of the output values, namely: the voltage and current for the 1F capacitor, and the values of current for three components within Micro-Cap's macro for this non-modified spark gap, namely: its current source – **G1**, its zero voltage source – **V1**, and its negative resistor – **R3**.

FIG. 34 lists almost all of the output values for the non-modified spark gap within the circuit of FIG. 32. The only value missing is for resistor, **R4**.

FIG. 35 is the output value for resistor, **R4**, within the non-modified spark gap within the circuit of FIG. 32.

FIG. 36 are the output values for the circuit in FIG. 32 minus the output values for its spark gap.

FIG. 37 are the nodal voltages of the non-modified spark gap within the circuit of FIG. 32. **Switchchk**, node #10, is exhibiting 10

volts which indicates that this spark gap is ON and arcing at the termination of this simulation.

FIG. 38 are the nodal voltages and a segregated analysis for the circuit of FIG. 32 minus the nodal voltages or segregated analysis of FIG. 37.

FIG. 39 is a manually calculated, segregated analysis of the non-modified spark gap for the circuit of FIG. 32. Although it is not a steady-state condition, because power (both reactive power and real power) is escalating due to the low resistances of  $1\text{m}\Omega$  for each resistor, and due to the precharged condition of the  $1\text{F}$  capacitor, and also due to the low equivalent series resistance of this capacitor at  $10\text{m}\Omega$ . Yet, it appears to possess a net gain of +258 Mega watts indicating an abnormal condition which *does not support* the conventional rule of thumb in which “energy IN [usually] equals energy OUT.”

Fifty years after the “discovery” of the electron and its present convention of naming its sign negative, it was discovered that the electron is (actually) positively signed.

When you look at the manually tabulated values of FIG. 39, you will notice a very interesting thing in which all of the watts are signed positive while the volts/amperes are signed negative. This is backwards to logic since the generation of anything (volts/amperes in this case) should also be *adding* power to a circuit while the consumption of anything (watts in this case) should always be *subtracting* power from a circuit. Yet, this is not the case. Hence, it is very *confusing!*

The reason given (by historians) why physicists did not bother to change their sign conventions when they discovered their error is that they were afraid that fifty years was too long to upset conventions by correcting their mistake by going public with it and requiring that everyone switch over to the new naming convention of a positively signed electron volt.

Yet, look what a hazard this has become in logically deducing what is happening in a circuit which is undergoing a segregated analysis....? It's obviously self-contradictory to say that watts are consuming the power of a circuit while labeling it with a positive sign, or to claim that reactive power is being generated labeled with a negative sign. But this is what fear and sloth has accomplished for the study of physics which we have inherited to this day – *over a century after* this mistaken labeling was first discovered!

FIG. 40 is an automated recalculation of the subtotaled electrical load of the three resistors and capacitor (top image) and an

automated recalculation of the subtotaled spark gap (bottom image) of the circuit in FIG. 32. This automated recalculation was performed by Micro-Cap in an attempt to be more precise. It worked...

FIG. 41 is another automated recalculation, this time of the grand totaled, segregated analysis of all of the components of the circuit in FIG. 32. It shows a net gain of nearly 119kW in 10 seconds. This is, definitely, overunity! *{Just nothing to write home about since the resistances in this circuit, outside of its spark gap, are very low. Not too low to build this circuit, but too low to power a load and retain its overunity.}*

FIG. 42 through FIG. 47 are a few more examples of this type of low resistance circuit. Included are their schematics and their outputs, nodal voltages, but without any segregated analysis (for the sake of brevity). These figures also exhibit the property of an escalating output due to their low external resistances of less than one Ohm and the low equivalent series resistance (ESR) of 10m $\Omega$  within their precharged capacitor. 3 $\Omega$  would have been more realistic since this circuit must suffer very high voltages. But that high ESR would have dampened their output into a mediocre state of conventional thermodynamic loss. Although these circuits of low resistances are overunity, and escalate to their own self-destruction, they are not practical since any connection to a load of considerable resistance will suppress their overunity. Hence, these conditions and their resultants are usually never paid any attention to by anyone for these obvious reasons.

The other interesting thing about these three runaway examples of overunity (FIG. 32 and FIG. 42 and FIG. 45) is the fact that their outputs escalate the fastest when their resistors are enlarged to approach as close as possible to the turning point, but still remain less than whatever it happens to be, in which any greater resistance above this turning point (of slightly less than one Ohm) will create the opposite (damping) effect depicted in the following figures.

FIG. 48 through FIG. 50 is a circuit schematic and its outputs, nodal voltages, but no segregated analysis (for the sake of brevity) which displays a distinct self-damping of its output probably due to its raised resistances having been elevated to one Ohm – which is above the turning point and confirms underunity of its output performance.

We've seen enough simulations of spark gaps to conclude that a spark gap is a randomized version of a pair of diodes embedded within an LRC “tank” circuit since diodes act as switches (and filters) for current, switching current ON for each half cycle (of an alternating cycle) and switching current OFF for each subsequent cycle in an alternating fashion so that (for instance) every odd numbered half-cycle

will have its current turned ON while every even numbered half-cycle will have its current turned OFF while allowing voltage to pass through for each half-cycle.

And we've reviewed Micro-Cap's macro for a neon bulb, spark gap so many times that we've become familiarized with its peculiar way of simulating the behavior of a spark gap. One of these peculiarities is the presence of a negative resistor which inverts the polarity of current causing this fictionalized electronic component to become a generator of reactive power. Another one of these peculiarities is the presence of a pair of diodes whose anodes are facing each other and with no other electronic component in between them (at node #6 in FIG. 15). I believe that the presence of these counter-opposing diodes merely enhances the negative resistance of resistor, **R3**, in FIG. 15 due to the enhancements added to the circuit of FIG. 51 (enhanced output at FIG. 64) and the circuit of FIG. 65 (enhanced output at FIG. 69).

By combining an LRC oscillator with a pair of diodes with opposing direction of their terminals, it becomes possible to simulate the generation of reactive power at a rate which is far greater than its electrical consumption at various components acting as loads....and retain its ability to be built!

This may, or may not, be what the Ammann brothers built, but this awareness arises as a consequence to the pursuit of understanding their mystery.

FIG. 51 is the schematic for one embodiment of this invention. This may be how the Ammann brothers built their device. And it may also be what pop culture refers to as Tesla's TriMetal Generator.

The reason why **L2** of FIG. 51 is magnetically coupled to **L1** & **L3** of FIG. 51 and **L1** is not magnetically coupled to **L3** is because **L1** is bare aluminum wire or aluminum wool stuffed inside of the copper spheres and the copper tubing which connects the spheres with each other and paramagnetically reflects back outwardly from **L1** (inside the copper tubing) the inductance of **L2** with reversed polarity (just like a mirror). The paramagnetism of aluminum severely reduces the direct coupling of **L1** to **L3** towards negligible values. So, I'll omit it until later on when I will include it for one exemplified variation of this circuit in FIG. 51. **L2** has 60k Ohms of series resistance and is wrapped around the copper tubing. **L1** has a series resistance of 2k Ohms inside of the copper tubing serving as its electrode. The aluminum is also acting as a self-referencing (parallel) capacitance internalized inside of the copper tubing. *{Tantalum may substitute for aluminum?}* This capacitance (inside of the copper tubing) is simulated with the help of 1 Farad, each, of parallel capacitance placed inside of the



simulated inductors, **L1** & **L2**. **L3** is a motor load of 25 AWG copper winding possessing 10 Ohms of series resistance and no parallel capacitance. All capacitors possess 3 Ohms of equivalent series resistance. **C2** prohibits the escalation of impedance at **L3**. The magnetic coupling of **L3** is to its armature, not to itself, since the copper winding of **L3** contributes a much smaller coupling coefficient than the contribution of its ferromagnetic armature. **X1**, **X2**, **X3** & **X4** are spark gaps filled with air possessing a voltage threshold of one kilo volt. Gear Approximation Method is simulated with RELTOL (relative tolerance) equaling 1.

The frequency of the sine wave generator, **V2**, is slightly faster than the frequency of the sine wave generator, **V1**, by 10% to create a beat frequency between them. This helps to insure the overunity gain.

The voltage precharged onto capacitor, **C1**, also regulates the overunity rate of gainful output.

The resistor, **R3**, of Micro-Cap's macro for a spark gap (in FIG. 15) turns the direction of current around at nodes #3 and #5 due to its negative resistance of  $1\Omega$  (spark gap, macro parameter: **RNEG** = -1).

Diode, **D1**, of Micro-Cap's macro for a spark gap prevents current, at node #5, from returning to itself from resistor, **R3**, by converting it into voltage and accumulating this voltage behind itself, at node #6, during each half-cycle of alternating voltage polarities.

Despite whatever D/C input may, or may not, enter from outside this spark gap, oscillations are initiated by the switching action of the two diodes, **D1** and **D2**, imposed upon their flow of current, and the gap capacitance at **C1**, and the arcing capacitance at **C2**.

Current source, **G1**, clones a quantity of current ten times greater than whatever voltage is behind itself at node #7, labeled “**Switch**,” if the voltage difference between **Pin #1** and **Pin #2** exceeds the breakdown setting for this type of spark gap (which is set to a default condition of 90 volts) and divides this voltage between **Pin #2** and resistor, **R4**.

Resistor, **R4**, impedes the current of **G1** by converting it into voltage on its opposing side at **Switch**, node #7, due to the impedance of current at diode, **D2**. This creates a positive feedback which escalates until it reaches whatever thermodynamic inefficiencies limit this runaway condition from escalating any further.

FIG. 52 are the nodal voltages of the circuit minus the nodal voltages of its four electrostatic gaps of air (ie, spark gaps).

FIG. 53 is a numeric output of the individual components of the circuit (acting as electrical loads) minus the output from its four electrostatic gaps of air. It hit its target, for an electric vehicle, of nearly 70kVA at inductor, **L3**, in slightly over 210 seconds while only turning ON one of its four spark gaps located at **X4** adjacent to this motor load. The inductor at the motor load, **L3**, is behaving as a generator of reactive power rather than behaving as a consumer of real power.

FIG. 54 is a chart of the numeric outputs of electrostatic gap, **X1**.

FIG. 55 is a chart of the numeric outputs of electrostatic gap, **X2**.

FIG. 56 is a chart of the numeric outputs of electrostatic gap, **X3**.

FIG. 57 is a chart of the numeric outputs of electrostatic gap, **X4**.

**V(X1.10)** through **V(X4.10)** are the ON/OFF conditions of the four electrostatic gaps of air. If their voltages are 10 volts, then they are ON. If they are approximately 10 nano volts, then they are OFF.

Nodal number **#10** in FIG. 15 is alternatively labeled “**Switchchk.**” The nodal voltage at this node is 10n volts indicating a double “false” condition of the IF/THEN test-statement of its **E2** behavioral voltage source:

```
IF (ABS (V (PIN1 , PIN2) ) > V (THRESH) , THEN E2 = 10 ,  
ELSE IF (ABS (I (V1) ) > ISUS , THEN E2 = 10 ,  
ELSE E2 = 10N
```

In plain English, this renders into the equivalent statement that: if the absolute value of the voltage difference between **Pin #1** and **Pin #2** of this spark gap macro is not greater than the voltage default setting for the threshold of the breakdown of resistance for this neon bulb macro (which is 90V), and if the absolute value of the current of **V1** is not greater than the default setting for the minimum current required for sustaining an arc in this macro (which is 500mA), then the nodal voltage for node **#8** will be set to the value of 10 nano volts and will be transferred to the left-hand side of resistor, **R5**, to node **#10** labeled **Switchchk**. This value of 10nV will then become a multiplier for calculating the voltage of current source, **G1**, when multiplied against the voltage difference between node **#7** (labeled “**Switch**”) and

**Pin #2.** This will result in a new value for voltage erupting from out of current source, **G1**.

This double false condition is indicative of this spark gap being in the state of “OFF,” namely: it is not arcing. Instead, an ionic channel is forming across its arc which is preliminary to the formation of an arc.

Despite the temptation to assume that this OFF condition renders this component (a spark gap) useless for the purpose of encouraging any circuit which utilizes it to accumulate dielectric potential, the presence of this arcing space is required to convert inductive loads into generators. Otherwise, without this arcing space (whether ON or OFF), inductive loads (for all intents and purposes) retain their consumptive quality and are incapable of providing for the generation of power.

So, don't expect that my invention (of a modified spark gap) will require its spark gap be in a condition of being ON (engaging in arcing/firing) in order for my invention to be successful. The low-scale, prefiring/prearcing warmup of its spark gaps are enough to render it useful. This is the unrecognized mystery of spark gaps which this invention capitalizes on and, thus, benefits from probably due to the occurrence of Mho's Law? In other words, spark gaps exhibit negative resistance regardless of their state of being ON (arcing) or OFF (not arcing; merely ionizing) their gap's gas/es.

ON versus OFF conditions don't seem to severely impact anything most of the time except for an enhancement causing the surge to escalate at a vertical rate of departure (up or down; enlargement of amplitude versus its diminishment) from the virtual oscilloscope's midline (of zero amplitude) when the spark gap is ON versus a gradual hyperbolic escalation when the spark gap is OFF.

FIG. **58** is an automated subtotal of the entire output of the circuit in FIG. **51** minus its four spark gaps. Its output is slightly greater than negative one-third of a volt/ampere.

FIG. **59** through FIG. **62** are the subtotaled outputs of the four spark gaps within FIG. **51**. They demonstrate a spike of wattage occurring around 200 seconds into the simulation amounting to a variation of a minimum of +30 milli watts and a maximum of +6 watts of real power. This is far greater than the one-third of a volt/ampere of reactive power being generated at the load (as depicted in FIG. **58**) as if to suggest that the spark gaps are attempting to periodically “soak up” (consume) the reactive power coming from the load in order to maintain thermodynamic equilibrium averaged out over time? I don't know. This would require several segregated analyses performed over

time to make a more definitive conclusion.

FIG. **63** is a manual tabulation of the entire circuit, plus its four electrostatic gaps of air. Its conclusion is that less real power (+1.0956 milli watts) disappears into its four sparkable gaps of air (although they are not sparking yet; they're merely ionizing/preparing to spark) by comparison to the  $-348.573$  milli volts/amperes of reactive power which appears at this circuit's inductive loads. These loads have become generators of reactive power due to this circuit's use of electrostatically energized gaps of air making Mho's Law manifest within these inductive loads. Also, more power continually amplifies over time from the scant seed power which initiated this circuit as a precharged condition of its capacitor, **C1**, of one volt in FIG. **51**. The absolute value of its two largest outputs are both exactly 69.33 kilowatts (**C2** and **L3**) by comparison to its manually computed totaled outcome leaves a remainder of  $-346.8267$ mVA. That's a ratio of about 210k to 1 of absolute value which is not bad for a lazy overunity circuit which takes its sweet time at achieving its goal of supplying adequate power for an electric vehicle.

FIG. **64** is a fully automated tabulation for the entire circuit which comes to us courtesy of Micro-Cap's grand summation of all of the components of this circuit (in FIG. **51**) plus all of its macro components of its four spark gaps. The software did not allow me to proceed to 214 seconds as it did during the previous simulations. Here, it is slightly asymmetrical in the direction of the consumption of real power producing a residue of +1.621 milli watts, rather than the slight asymmetry, exhibited in FIG. **63**, of the production of reactive power with spikes of humongous amplitude of real power. The largest spike occurs at 160 seconds reaching upwards to +10.353 mega watts.

It's not always easy to conclusively compute the outputs of the behavior of a circuit containing one or more spark gaps. Very often I'll get inconclusive results. So, in those cases, I'll look for a trend. If I can see a trend occurring, then I can extrapolate what might be happening.

But in this case, I'm not sure whether these discrepancies are due to “slippage” of causality among the various components of this circuit, or else is due to repercussions stretched over time requiring several segregated analyses to quantify these anomalies. I don't know.

FIG. **65** is the schematic for the construction of an enhanced embodiment for the circuit in FIG. **51**. Here are its construction details...

**L1** is the “inner,” primary, coil of the Ammann brothers' Atmospheric Generator's transformer. To represent its parallel capacitance

(of one Farad), it is filled with bare aluminum wire or wool which has been “conditioned” by first using this material as the terminus of one electrode while another electrode of some other material are both immersed into an electrolyte of borax (or, baking soda) and both electrodes are energized with an A/C current to cause a layer of alumina (aluminum oxide) to form on top of the surface of this bare aluminum wire or wool, and then stuff a copper pipe with this conditioned material, and then hold this copper pipe in a vertical orientation, and then position a Bunsen burner flame underneath one end of this copper pipe to cause a stream of hot air to rise upwards through the interior of this copper pipe to dry out any lingering moisture which may be adhering to the surface of the conditioned material.

If the iron winding of inductor, **L2**, is without insulation, then the Henrys of **L2** is defined by its diameter of bare iron, single layer winding (not by its mass as is the case with conventional windings {of today} predicated upon when winding copper – not iron – coils). **L2** is, then, wound upon a wicker-style frame of iron rebar setting each turn of winding apart from its previous turn to create a capacitant spacing between each turn of winding.

But if the iron winding of inductor, **L2**, is insulated, then its mass is significant and its winding should be fill its entire radius. I am not capable of determining which is the case prior to an actual build.

The coupling coefficient between **L2** and **L3** is 99.9999999% due, not to proximity between its pair of coils, but -instead- due to their coupling between their iron masses: the mass of iron armature upon which is wound the stator and starter coils associated with **L3**, and the iron winding of **L2**. In actuality, the distance of their separation is a radius of several miles determined by the radius of **L2** (simulated by the inductance of **L2**).

The inductance of **L1** is weak due to it being constructed of a mere copper tubing whose interior is partially filled with aluminum. Its resistance is also low due to its shrunken mass.

You'd think that the diodes, **D1** and **D2** of FIG. 65, are oriented backwards? Shouldn't their cathodes be pointing towards inductor, **L2**, instead of pointing towards inductor, **L1**? Isn't aluminum material stuffed inside of the copper tubing (which represents inductor, **L1**) acting as an anode? That would mean that these two diodes should be pointing their cathodes *away* from inductor, **L1** – not towards it! But this is not the case. Why?

Because it doesn't need to be.

The parallel resistance of inductor, **L1**, already takes care of representing the presence of aluminum material inside of the copper tubing which is being simulated, here. So, a counter-balancing action is required to encourage – not a throughput of current, but the prohibition of current and, instead, encourage the buildup of voltage and take advantage of the cross-wiring of capacitors, **C5** and **C6**, to further the encouragement of this buildup of voltage.

To further discourage the flow of current, this cross-wiring of capacitors, **C5** and **C6**, will neutralize back EMF of both inductors: the massive iron winding of **L2** and the copper tubing of parallel resistance (brought about by stuffing it oxidized aluminum material) by converting any and all currents, driven by both forwards and backwards EMFs, into voltages which are immediately stored into capacitors, **C5** and **C6**.

We don't want current to manifest at these two inductors (of **L1** and **L2**). We want voltage, alone, and lots of it, to convey to the shorted inductive motor load, **L3**, the electrical equivalency of torque which it will require to serve as a necessary backdrop for whatever current becomes manifest at inductor, **L3**, due to its self-shortened condition. Self-shortening of coils tends to deplete them of their voltage rather quickly. So, we want a backdrop of torque to be provided by its electrical equivalency of voltage which will be accumulated at inductor, **L2**, and magnetically transferred towards inductor, **L3**, to support the function of inductor, **L3**, to serve as a motor load.

Pointing the cathodes of diodes, **D1** and **D2**, will force the paramagnetism (exhibited by the parallel capacitance of inductor, **L1**, possessing oxidized aluminum material for its inner composition) to export its capacitant voltage to inductor, **L2**. Inductor, **L2**, will (for the most part) be the most significant influence to magnetically transfer this voltage to inductor, **L3**, as a step-down reduction of its voltage along with a concomitant increase of current at inductor, **L3**.

It's very important to conserve voltage. The conservation of voltage is the only safeguard an electric load of vast consumption, such as: an electric vehicle, possesses to maintain its ability to provide itself as a source for its own need for maintaining a condition of high voltage and replace our dependency upon battery packs, and the need for recharging these packs of batteries from the power grid or from solar panels and, thus, liberate our E.V.s from their umbilical extension cords. Hence, everything about this circuit – apart from inductor, **L3**, is merely intended to amass and conserve against the loss of the accumulation of voltage in a fraction of a second to rapidly accommodate

the appetite for power required by electric vehicles.

Aluminum and copper are poor mediums for magnetic transfer. Hence, the coupling coefficient for inductors, **L1** and **L2**, is simulated (and assumed) to be quite low –  $1/10^{\text{th}}$  of 1% in this simulation of FIG. 65. Meanwhile, the coupling coefficient for inductors, **L2** and **L3**, is a theoretical value nearly equivalent to idealistic unity due to the mass of iron contained within the winding of inductor, **L2**, and within the armature of the motor load at inductor, **L3**, and surrounding these two inductors, **L2** and **L3**. This is why Tesla was quoted to have said that, “one horsepower of the output (of Tesla's Special Generator) will increase with each additional 200 pounds of iron attached to his Special Generator.”<sup>40</sup> Although a direct/physical coupling of additional iron mass was required of Tesla's Special Generator to benefit the output of his Special Generator, this may have a direct impact upon whatever inductors are within the vicinity of inductor, **L2**, within the device of the Ammann brothers and not necessary to have it electrically attached. This “vicinity” is several miles of radius according to C. Earl Ammann during his newspaper interview.

This increase of horsepower is *not* linear. It is exponential. The closer a magnetic coupling approaches unity, the more it may accelerate its contribution of power acting as a current source.

This fact, I achieved to my satisfaction, by modifying the software code of Paul Falstad's electronic simulator<sup>41</sup> to allow for a mutual inductance up to, and beyond, unity.

My experience, although idealistic, with a mutual inductance of unity brings about an instantaneous explosion of “infinite matrix” error messages indicating that its computation of output via matrix algebra is yielding this seemingly illogical outcome. Any coupling coefficient which was substantially greater than unity gave more modest gains of output. And any coupling coefficient which was slightly greater than unity, such as a mutual inductance of 1.01, was surprisingly more explosive than values of mutual inductance which were substantially greater than unity. This indicates to me that mutual inductance is *not* a linear action. Far from it! It is an exponential

---

40 This quotation comes to us by way of a Mr. Dort whose father had presumably worked with the Nazis during WWII on their theft of Tesla's Special Generator from his lab in 1895 at the time of its arson-based fire according to William Lyne who met with Dort's son as reported to us in Lyne's book, entitled: “Pentagon Aliens”. See, footnote #42.

41 My mirror of Paul Falstad's electronic simulator with my revisions. → <http://vinyasi.info/ne>

relationship. Hence, it is easy to deduce that *any* increase of the mass of *any* iron – held in proximity to the field of mutual inductance among multiple inductors – stands a good chance of increasing an exponential gain (not a thermodynamic loss) of magnetic remanence among mutually coupled inductors.<sup>42</sup>

This is why Tesla chose, for his demonstration of 1931, a massive Pierce-Arrow composed of lots of iron in its chassis instead of a light weight car made of non-ferrous material. And this is also why his Special Generator was installed by the Nazis during WWII into several Electro-U-Boats whose massive iron hulls contributed lots of iron to the output of his Special Generator used in those U-Boats to recharge their banks of batteries without having to resurface since his Special Generator ran on compressed air stored as liquid air in various tanks on board these submarines.

Permanent magnetism is equivalent to magnetic remanence and also equivalent to mutual induction (magnetic coupling) which is also equal to inductivity which spawns inductive reactance. This is why Tesla suggested to use more iron attached to his Special Generator since permanent magnets of sufficient strength were not available over a century ago when he invented his Special Generator in 1893 to accommodate its need for a very large and powerful Perpetual Motion Holder. And this is why my electronic analogues of the Ammann brothers' device, in FIG. **51** and FIG. **65**, has to have a minimum of 10k Henrys of induction and wound with iron wire (giving my coil a resistance of 60k Ohms) to substitute for its lack of permanent magnetism.

Thus, it may truly be said that capacitive reactance is what 180° reversal of voltage amounts to, but only if the capacitance is saturated. And this saturation can only occur if bombarded by the back EMF erupting from out of a very high inductive reactance.

In FIG. **51**, I place the one Farad capacitor inside of each of the pair of 10k inductive coils as a parallel capacitance. But in the other scheme, of FIG. **65**, this parallel capacitance is held outside of this enlarged inductor and adjacent to it which, hence, requires that I cross-connect two small capacitors along diagonal axes and point the cathodes of two diodes away from this large inductor to force electric charge to remain inside of these capacitors and quickly accumulate a condition of complete saturation of electric charge and refuse to admit any more charge into themselves and, thus, become reflectors of electric charge rather than acting as absorbers and dischargers. And since

---

42 <https://is.gd/12voltcap> (simulation) → <https://is.gd/magrem> = <http://vinyasi.info/vinnie-folder/SIMPLEST.jpg>



reflection of the electric field is instantaneous requiring no transit time since nothing is traveling, the speed of light is transcended without its violation due to the lack of involvement of any current. The reversal of voltage is strictly that: a reversal of voltage. Current is not affected, nor is it involved, in any way whatsoever, due to a puritanical interpretation of Ohm's Law in its original format (at equation §2.1a)...

$$Power = Watts = \frac{Voltage^2}{Resistance} = Ohm's Law \tag{§2.1a}$$

Where is there anything to suggest the existence of current devoid of any preconceived notions or prejudicial inclinations? I don't see any! But then again, I'm not brainwashed...

Thus, do we get a condition of primal movement without the need for any exteriorized presence of a prime mover simply by inverting voltage by one-half cycle of an alternating cycle from a voltage source. And under this condition of voltage reversal, any inductor which comes under the influence of this voltage reversal will become a generator of reactive power despite its lack of motion through a field of magnetism and, thus, transcend Michael Faraday's Law of Induction which requires movement and, yet, we need not provide any movement in this scheme and, yet, produce the same results! Fantastic...!!

Looking up this topic on the Internet, this citation<sup>43</sup> yields the concept of “coercivity” which sounds equivalent to the enlargement of mass of iron which Tesla was referring to?

The diodes, **D1** and **D2**, have their cathodes pointing towards the parallel capacitance of the aluminum oxidized wire or wool of **L1** which, at first, may seem backwards since the oxide only forms if the aluminum is serving as the anode of a diode. But the cross-wired capacitors, **C5** and **C6**, are effectively reconnecting the anodes of these two diodes with their origin at the parallel capacitance possessed by inductor **L1** by the use of a cross-wired connection. This cross-winding lends stability to what would otherwise be considered an unstable circuit (which is what conventional wisdom calls overunity, free energy circuits: unstable). This makes the task of Micro-Cap simulator a bit easier to compute the outcome with less error which tells me that this is also a good idea to use this feature in the actual, physical build.

The diodes, **D1** and **D2**, could be represented in their electrical analog as a pair of diodes possessing an aluminum anode and an iron

---

43 “Permanent Magnets” → <https://is.gd/mixala> = <http://hyperphysics.phy-astr.gsu.edu/hbase/Solids/magperm.html>

cathode if, in your physical build of this device, you wished to avoid the use of oxidized aluminum material stuffed inside of copper tubing when building your own version.

The circular polarity of **L1** relative to **L2** is significant. They must possess a continuously, unbroken orientation of direction to their windings. Yet, this is automatically taken care of due to omnidirectionality of the polarity of a magnetized copper tube (**L1**).

The precharged condition of capacitor, **C1**, is one factor which regulates the rate of amplification of output. A greater voltage input, here, accelerates the growth of output.

Resistor, **R1**, in between the two ground nodes, registers a voltage difference of zero volts, because the Ammann brothers are using the chassis of their EV conversion as their ground nodes for both copper spheres and this resistor represents the resistance of their chassis between both headlight sockets. These spheres are attached to the headlight sockets of their car and replaces its headlamps. They are electrically connected to the car's chassis. The mass of iron within the car's chassis may be a significant contributor of amplification due to what Tesla has been quoted by a Mr. Dort (via William Lyne in his book, entitled: "Pentagon Aliens"):<sup>44</sup> "for every 200 pounds of iron added to Tesla's Special Generator, one horsepower is added to its output." This is merely one reason why I believe that Tesla may have been replicating and improving upon the Ammann brothers' demonstration when Tesla performed his own demonstration ten years later with a Pierce-Arrow which weighs over 4k lb.

Aluminum must be at the core of this device's power transformer, simulated herein by inductor **L1** (being made of a copper tube filled with oxidized aluminum material), but whose dormant coils are wound with iron and surrounded by an iron case – the more iron the better, but its active windings are of copper. All of these dormant windings of this transformer is simulated by **L2** and is exclusively of iron. And the chassis of the Ammann brothers' car contributes the iron of its construction to the iron of the motor's armature and conveys its iron influence into the copper windings of the car's motor to become actuated.

The copper tubing minimizes the use of copper needed to transfer the magnetism of the aluminum to the iron winding of **L2**, and vice

---

<sup>44</sup> "PENTAGON ALIENS; CHAPTER VIII: A TASTE OF OTHER ENERGY SECRETS" → <https://is.gd/anavum> = <https://www.bibliotecapleyades.net/ciencia/pentagonaliens/pentagonaliens08.htm#CHAPTER%20VIII:%20A%20TASTE%20OF%20OTHER%20ENERGY%20SECRETS>

versa, and not get in the way of focusing our objective on the near exclusive buildup of power without encouraging its dissipation. Its dissipation would have been encouraged had more copper been used surrounding the aluminum core. This should reduce the manifestation of heat at this transformer to indicate less manifestation of usable power at the transformer saving as much of it as is possible for its thermodynamic conversion/dissipation at the car's electric motor.

There's usually a core idea which initiates my development of an overunity circuit plus enhancements. The enhancements accelerate the amplification of “freely available” reactive power to help make that device more practical.

You'll notice that this improvement, in FIG. 65, is no longer capable of adhering to an authentic style of build according to whatever the Ammann brothers managed to succeed at, because I lack the imagination required to envision how the two cross-wired capacitors, C5 and C6, could be built according to the style of build utilized by the Ammann brothers. *{In other words, we may have to dispense with the use of copper tubing and replace this with a simple inductor to represent L1 and parallel connect this to a capacitor, C7, in FIG. 65.}* At this point in the development of this circuit, it becomes necessary to divorce one's self from adherence to authenticity of whatever the Ammann brothers managed to accomplish and strike out on our own – which may be what Tesla managed to succeed at accomplishing ten years after the Ammann brothers?

Anyway, the 8 micro second duration required to accelerate the growth of reactive power is so fast, in FIG. 67 and FIG. 68, that it far surpasses the 214 seconds required to amass a largess of power in FIG. 51 and also manages to make possible the elimination of the pair of frequency sine wave inputs, V1 and V2 utilized in FIG. 51 and, thus, invalidate any requirement for remaining true to the Ammann brothers' claim of “energy from the air” – the description of their Atmospheric Generator.

Where is the growth of energy coming from to amplify the initial one volt, which had been precharged onto the one pico Farad capacitor, at C1 in FIG. 51 and in FIG. 65? That's all that is necessary to initiate an infinite growth of reactive power against considerable impedances and resistances.

This precharge (on C1 in FIG. 51 and in FIG. 65) could come from a short aerial? Or, the result of voltage division powered by a postage stamp-sized solar cell?

This growth of reactive power is coming from the inductive loads, all of the coils, associated with this device, as if to suggest that these coils have become convinced that they are moving through an electromagnetic field and this movement is magically induced by some invisible prime mover. Apparently, spark gaps can “authorize” inductors into becoming prime movers by “faking” their rotation, and movement, by substituting an electrodynamic field of inverse polarity of voltage relative to current to in place of movement of an inductor through an electromagnetic field and, thus, satisfy Mho's Law and, also, satisfy Michael Faraday's assertion that movement through this type of field initiates a changing trend (over time) of electromagnetic input entering into inductors forming current within these inductors effectively causing these inductors to become generators of reactive power.<sup>45</sup>

Rapid switching can do this....that is, if we could invent mechanical switches that could withstand the rigors of high speed switching. But diodes do this with ease for one half of each alternating cycle. And spark gaps also provide negative resistance in addition to electrical behavior reminiscent of ultra-fast, mechanical switching.

Spark gaps incorporate diodes and negative resistance and inductive and capacitive reactance all into one innocent looking space between two pieces of metal!

It's as if the Federal Reserve were to make the announcement that we don't need banks anymore, nor do we need to work for money, when we can mint our own money all by ourselves out of practically nothing by creating free energy to run all of our appliances!

You may either assume that this is a ridiculous thought and dismiss it on that premise, alone. Or, you may dismiss it on the premise that we don't want that kind of world to live in for fear of how dangerous is a world without workers and without money. Either way, you'd be against this technology.

But that didn't stop the Ammann brothers. Nor did it stop C. Earl Ammann from evolving towards his fate of arrest within the jurisdiction of Washington, D.C.

Normal circuits – which create overunity when they are simulated in the domain of the virtual reality of electronic simulators, such as the world of Berkeley SPICE, or Paul Falstad's simulator, all share one thing in common which makes it easy to create a state of overunity –

---

<sup>45</sup> “Faraday's law of induction” → <https://is.gd/opamoc> = [https://en.wikipedia.org/wiki/Faraday%27s\\_law\\_of\\_induction](https://en.wikipedia.org/wiki/Faraday%27s_law_of_induction)

much easier than in the real, concrete world of disappointments: they see a circuit – no matter how large and complicated – from a bird's eye view in which all of the components are timed at the same clock time as the simulator is running on so that the occurrence of any behavior of each and every component occurs at the same time. In the real world, this would never happen resulting in a compositional multitude of beat frequencies which will manifest throughout the circuit and, thus, make it much harder for the condition of overunity to occur.

Overunity, brought on by inductive reactance, is less demanding than that of capacitive reactance since coils are sloppy instruments. Their reactance is layered with the complexity of beat frequencies making them notoriously inefficient at creating overunity.

Capacitors, on the other hand, are very efficient at creating overunity with the caveat that they have very narrow tolerances for punctuality. They must discharge at precise moments spending far less time than the time consumed whenever they are charging up.

This punctuality is automatically provided by simulators which make the mistake of running all the components of a circuit by the same beat of the simulator's clock timer.

Inductors don't discharge at precise moments. Waves of induction pass through coils with no well-defined beginning nor any well-defined terminus to their waves. So, inductors don't need to be punctual, nor can they be.

Yet, overunity requires both capacitive as well as inductive reactance to be complete. Only by the union of these two halves can the phase of voltage become inverted (relative to the phase of current) and generate power with no input from any outside prime mover.

So, for the sake of capacitive reactance, punctuality is a must.

For simulators, this is easy. But for circuits in the real world, we have forgotten how important this is, as well as having forgotten how to accommodate circuits in this regard.

FIG. 66 demonstrates three examples of how to accommodate the imperfections of the real world when it comes to making sure that all capacitors charge, discharge or reflect at exactly the same time.

If one or more capacitors should be grouped together with others as a symmetrical set, such as: **C5** and **C6** in Fig. 65, then layer all four plates (of this pair of capacitors) into one multi-layered capacitor by interleaving their plates in an alternating fashion to maintain

correct polarity of charge on every odd-numbered plate versus every even-numbered plate. This way, whenever one capacitor will either charge one plate or discharge its opposing plate, these activities will occur at the same time and without the need for having a simulator's clock regulate these activities in pace with each other. Thus, we will overcome the tendency for a circuit's capacitors to fall out of sync with each other and, instead, be able to mimic the ease with which an electronic simulator may produce free energy with that tendency in mind and be able to support Mho's Law under the auspices of the inversion of the phase of voltage relative to the phase of current within the context of an alternating polarity of voltage signs.

FIG. 67 are the nodal voltages for the circuit in FIG. 65.

FIG. 68 and FIG. 69 are the graphic and numeric outputs for the circuit in FIG. 65, respectively.

FIG. 70 is the same as the circuit in FIG. 65, except that this circuit is intended to give the circuit in FIG. 65 a means of shutting itself OFF by way of grounding both terminals of inductor, L2. Notice how this circuit is not entirely shut OFF? Only its reactance is shut OFF. Its thermodynamic dissipation remains ON giving it a residual quantity of power.

FIG. 71 are the nodal voltages of FIG. 70.

FIG. 72 is a numeric and graphic display of the throughputs for some of the components of the circuit within FIG. 70, apart from the throughputs for the four neon bulbs (for brevity).

Anytime two diodes face in opposing directions, facing away from each other, suggests an area between their pair of anodes which is outside of, and *in parallel to*, the circuit to which these two diodes appear.

Anytime two diodes face in opposing directions, facing towards each other, suggests an area between their pair of cathodes which is also outside of, and *in series to*, the circuit to which these two diodes appear.

This is another purpose behind the use of diodes, D1 and D2, within the circuit of FIG. 65.

In fact, four alternative schematic symbols for a spark gap – depicted on the right-hand side of FIG. 73, by comparison to Micro-Cap's use of a capacitor symbol surrounded by a circle – depicted on the left-hand side of FIG. 73, are a pair of diodes whose cathodes are

facing each other across a small gap!<sup>46</sup>

In Micro-Cap's normal simulation of a spark gap, neon bulb (depicted in FIG. 13 and FIG. 15), this area between diodes **D1** and **D2** (and behind their anodes) fails to contain anything since it has been assumed, by convention, that a neon bulb will be encased in a dielectric enclosure, such as: a glass bulb, and not surrounded by an inductor (**L2**).

The Ammann Brothers replaced a dielectric enclosure with a copper or bronze enclosure which constitutes a parallel connection with the environment surrounding their undisclosed use of a spark gap.

Their use of a copper tubing unites the aluminum-based paramagnetic inductance inside of the copper tubing with the iron winding which surrounds this tubing.

We might choose to use tungsten material, instead of aluminum, since tungsten may be more paramagnetic than aluminum? But I'm not convinced this would be a good choice since whatever we choose to use must also exhibit the properties of a dielectric material as well as the properties of a paramagnetic material.

Aluminum may be an equivalent choice over tantalum? We want this material to first store dielectric potential within itself and, then, paramagnetically shift the magnetism, which will be congregating inside this invention, to become exported outside of this device towards the copper tubing, which surrounds the ionized air or arcing plasma, so that the copper tubing may further transfer this magnetism towards, and into, the iron winding surrounding this tubing. Thus, this aluminum will perform a function analogous to a magnetic diode. But if tantalum can do a better job, then so be it.

This is an appropriate analogy since diodes were constructed of two plates, one made of aluminum and the other plate usually made of lead (or else, any other material other than aluminum will suffice) with an electrolyte of baking soda or borax between these two plates a century ago when the Ammann brothers discovered these various properties of material substances. The aluminum will develop an oxide coating causing it to prevent the passage of current outwards through itself making this aluminum plate the anode and the opposing plate the cathode.

---

<sup>46</sup> Spark gap schematic on Wikimedia Commons → <https://is.gd/asanuk> = [https://upload.wikimedia.org/wikipedia/commons/2/29/Symbol\\_Spark\\_gap.svg](https://upload.wikimedia.org/wikipedia/commons/2/29/Symbol_Spark_gap.svg)

Diodes shift current towards their cathode and voltage accumulates behind their anode. Any loss of voltage, by the passage (leakage) of current through almost any component is a cost of efficiency. But since we're dealing, here, with an abundance of freely available reactive power generation, I'm not going to cry over the loss! *{And neither do the operators of UFOs cry over their loss of energy exported outside their craft for lack of motor load coils to temporarily store reactive power while their craft is in use! They can't retrieve this reactive power by returning it to their power supply whenever they turn it OFF. Once this energy leaves their craft and enters their immediate environment, that energy is lost forever. But who's crying over that loss if they're also using a free energy device to power their anti-gravity mechanism?}*

Since node #5 is directly in front of diode, **D1** (depicted in FIG. 15), as well as adjacent to negative resistor, **R3**, any voltage which deposits there immediately gets shifted behind diode, **D1**, and accumulates behind **D1** in the space between **D1** and **D2** which is where I want lots of voltage to accumulate and amplify, by virtue of the fact that this location, between **D1** and **D2**, is also outside of this spark gap in as much as it is behind the anodes of **D1** and **D2**. But the difference, here, from node #5, is that node #5 is a series relation with the environment surrounding this spark gap macro while this space between **D1** and **D2** is a parallel relation with the environment surrounding this spark gap macro.

I learned this by experimenting with the placement of a ground connection at node #5 and placing a pair of counter-wound inductors in series with each other and in between diodes, **D1** and **D2**, plus a capacitor in between this pair of inductors and in series with them. Although this experiment was fictional, in as much as it may not be buildable, nonetheless, I learned a lot from that exercise of my imagination, because these two inductors became highly efficient acting as primary windings of a transformer-style coupling to a motor load and, thus did they, protect the power supply from the motor coil's load so as to prevent the suppression of the inversion (negation) of the phase of voltage relative to the phase of current and, consequently, protect the condition of super-conductance (at room temperature, or thereabouts) authorized by Mho's Law by the use of electrical isolation to quarantine inductors from manipulators of voltage inversion.

Inductors exhibit free energy by becoming their own generators even if they had been designed with the intention of merely consuming power as an electrical load. But this can happen only if inductors are isolated from whichever components of a circuit, such as: spark gaps, orchestrates this anomaly to occur.

Electrically isolate the super-conductivity of this invention's type of power supply from the inductive load – to which its power will



be magnetically transferred – so as to insure its success of achieving the goal of overunity of the coefficient of performance as stated at the opening of this discussion.

Iron passes magnetic remanence without any tendency to forget its orientation of having been magnetized on any prior occasion immediate to the present moment. This the basis for computer core memory techniques of operation dating from the years of 1955 to 1975 in which two strands of copper wire were threaded through a cloth arrangement of ferrite rings. Each ring possessed one bit of information: either a one or a zero, depending on the direction of its magnetic remanence. The remanence stayed in perpetual orientation until acted upon by contrary forces (Newton's Law of Motion: an object tends to stay in motion, or stay at rest, until acted upon to do otherwise)<sup>47</sup> at which point the remanence would release its orientation as a bit of information (in the form of energy) before storing the subsequent bit (of informational energy).

This lack of forgetfulness of magnetic remanence implies that magnetism cannot impede its own memory in FIG. 74.

Magnetic remanence is vaguely analogous to inductance since it is the memory of inductance having been applied to an inductor and has not been altered by any new inception of inductive influence coming from outside the inductor, or fed into it via current, or arising from inside the inductor as its reactance. Yet, we are not given any parameter within the Berkeley SPICE model of simulating electronic circuits to represent this very important feature of electrical engineering.

The Nazis who made use of the German theft of Tesla's Special Generator<sup>48</sup> (which was stolen from Tesla in 1895 nearly half a century prior to the rise of Hitler) felt magnetic remanence was so important that they staked the performance of their use of Tesla's Special Generator on increasing its magnetic remanence by adding more iron to it by way of bolting this Special Generator to the floor of its location adjacent to the bank of batteries that were going to be recharged with it inside of whichever of their Elektro-U-Boots (electro-U-boats) were equipped with this device. This type of vessel gave this machine lots of iron to increase its output. And Tesla's use of a four thousand pound

---

47 “Newton's laws of motion; Newton's first law” → <https://is.gd/uxebof> = [https://en.wikipedia.org/wiki/Newton%27s\\_laws\\_of\\_motion#Newton%27s\\_first\\_law](https://en.wikipedia.org/wiki/Newton%27s_laws_of_motion#Newton%27s_first_law)

48 [https://is.gd/spec\\_gen](https://is.gd/spec_gen) = <http://vinyasi.info/circuitjs1/texts/Nikola%20Tesla/The%20Inventions,%20Researches%20and%20Writings%20of%20Nikola%20Tesla,%20ch.%2063.pdf>

Pierce-Arrow also contributed lots of iron to whatever method Tesla was using to power his EV conversion of 1931.

How do we know this?

I don't know. All I know is the expertise of Edward Leedskalnin who promoted this concept in a Perpetual Motion Holder, and Nathan Stubblefield who incorporated lots of iron in his patented Electric Battery, and my use of iron wire in replicating Leon Ernest Eeman's biocircuit which was far superior to Leon's use of copper wire – so much so, that I staked my first provisional patent application on this preponderant use of iron as an experiment to try and better understand this persistent emphasis on the use of iron in Tesla's Special Generator, and William Lyne's quotation of Dort's son quoting his father who, in turn, was quoting Tesla.

And...

In FIG. 74 and FIG. 75 and FIG. 76, I managed to rewrite the software code of Paul Falstad's simulator to accommodate my need to increase magnetic remanence by way of increasing mutual inductance among transformer coils<sup>49 50</sup> since this was the only way I knew how to effectively insert magnetic remanence into Paul's software as a variable parameter.

In Micro-Cap, this software only allows me to increase inductance. So, I raise the inductance of inductors, **L1** and **L2**, in FIG. 51 and inductor, **L2**, in FIG. 65 to 10k Henrys and add 60k Ohms of resistance to simulate the use of iron wire in these coils.

LTSPICE is similar in its lack of creative imagination for its failure to accommodate my need to insert magnetic remanence into an inductor.

It could be that inductor, **L2** of the circuits of FIG. 51 and FIG. 65, is not – in reality – that high of an inductance if we are to attempt to remain true to a replication of the Ammann brothers' device by boosting magnetic remanence. The inductance of inductor, **L2**, may be much smaller?

---

49 <https://is.gd/coremass> = <http://vinyasi.info/ne?startCircuit=coremass.txt> → maintains a steady-state of output because it has already made use of its “growth” phase and is engaging its maintenance stage of “coremass” to steady its output.

50 <https://is.gd/addinduct> = <http://vinyasi.info/ne?startCircuit=addinduct.txt> → gives instructions for initiating this circuit from a cold start to whatever level of output is desired before shutting down this escalation in favor of maintaining it.

But I know of no other way to simulate it.

The purpose of wrapping an iron winding of very large inductance around the copper tubing (capped at both ends with copper spheres and filled with air and aluminum material) is to transfer the ionic or plasmic electrical activity of the air molecules (held inside this arrangement) into eddy currents inside the copper tubing and then translate these eddy currents into an inducement of magnetic fluxes occurring within the singular iron winding immediately surrounding this tubing.

The purpose of the reduced diameter of the copper tubing, relative to the diameter of its two end caps of copper spheres, is to create a dielectrical Venturi Effect within the tubing which will accelerate the reciprocating motion of the eddy currents along the entire length of the tubing.

The paramagnetic and dielectric material (in the shape of metallic wire or wool) within the tubing and adjoining spheres serves a dual role of offering resistance along the interior of the tubing and spheres – to prevent arcing (shorting) across the diameter of the tubing and spheres, and also store dielectric charge potential which will accumulate and enhance the amplitude of the eddy currents arising in the copper tubing.

Here is the secret to how my two speculative attempts at replicating the Ammann brothers' mystery, in FIG. **51** and FIG. **65**, succeeds at inverting voltage and generating an endless supply of reactive power...

FIG. **51**...

A large parallel capacitance (PC) is placed inside of an inductor. Let's call this **L1**.

A very large inductance (Henry) is at another inductor, **L2**.

These two inductors are connected in a series loop so that each feeds the other and the direction of their windings remains the same along the entire route around the circumference of their looped interconnectivity.

If the inductance of **L1** is going to be as large as the inductance of **L2**, then **L2** must also contain a very large parallel capacitance as exhibited in FIG. **65**.

So, to summarize...

The first choice is demonstrated by the circuit in FIG. 51...

Inductor <b>L1</b>	Inductor <b>L2</b>
1 Farad PC	no PC
10n Henry	10k Henry

The PC of **L1** is servicing the back EMF of **L2** by inverting the voltage of both coils which is inductively significant at **L2** due to its enlarged inductance and non-existent parallel capacitance, while it is also capacitively significant at **L1** due to its enlarged parallel capacitance and very low inductance creating an escalating amplitude of triangular waves.

The second choice is demonstrated by the circuit in FIG. 65...

Inductor <b>L1</b>	Inductor <b>L2</b>
1 Farad PC	1 Farad PC
10k Henry	10k Henry

The PC of **L1** is servicing the back EMF of **L2**, and the PC of **L2** is servicing the back EMF of **L1**. Each PC is inverting the voltage of the other coil creating an escalating amplitude of triangular waves.

The first choice, from above, is also exhibited by the circuit in FIG. 75 and FIG. 76, below, by using a very large magnetic coupling percentage, but is less effective (than parallel capacitance of a partnered large coil) requiring a much greater mass of iron to produce similar results....

Transformer at...	Top of schematic	Bottom of schematic
Coupling Coefficient...	1.01	1.00E+008
For accelerating the growth of reactive power...	2.5E+11 Henry on each primary and secondary coil	1 pico Henry on each primary and secondary coil
For slowing down the growth of reactive power...	1E+18 Henry on each primary and secondary coil	1 pico Henry on each primary and secondary coil

The elevated magnetic coupling, of  $1E+8$ , at the transformer at the top of the schematic in FIG. 75 and FIG. 76 is servicing the back EMF of the enlarged inductance, of  $2.5E+11$  Henry, at the transformer at the bottom of the schematic in FIG. 75 and FIG. 76 by inverting the voltage of each other's coils creating an escalating amplitude of sine waves.

Back EMF is not such a bad thing if we can get it to work for us, rather than against us.

C. Earl Ammann was falsely charged with “stealing energy from the grid” in 1921 when he entered Washington, D.C., to deliver his electric car conversion, serving as a working model, to the United States Patent Office. By the standards of today, plus my discovery of the methodology behind his device, leads me to conclude that he should not have been falsely charged with theft, but -instead- more accurately charged with acts of “domestic terrorism” since he gave energy to the grid within the scope of downtown Denver, Colorado and disrupted the frequency and phase relation of the entire grid located within the radius of his influence. He did not steal any energy at all.

He gave a disturbance of phase relation and frequency to the area within the dozen or so mile radius of influence wherein his device furnished power to the grid. But at the periphery of this circle of influence, no significant amount of power was able to reach the grid. Instead, a significant amount of disturbance reached this peripheral area, just as it also reached the interior of this radius of influence, which caused an electrical blackout since he caused a translation of real power into reactive power at this peripheral perimeter. And since this demonstration of his, and his brother's car, was not foreseen by the engineers who had installed the electric power grid of Denver, Colorado,

no correction for reactive power had been installed to safeguard the grid from this type of disturbance. So, the real power of the grid at the foothills surrounding downtown Denver went down towards zero by becoming converted into reactive power of no practical benefit to the customers of the grid. From the perspective of the customers' appliances at this peripheral location, useful real power disappeared into the domain of invisibility for all intents and purposes since it translated into reactive power leaving no real power left remaining to power anything.

These segregated analyses confirms what Eric Dollard has to say about Nikola Tesla's method for transmitting power. He didn't transmit. The power simultaneously appeared at both the transmitter and at the receiver of Tesla's Magnifying Transmitter – *under construction, but never implemented, at Wardencllyffe, near the village of Shoreham on Long Island, New York, and thoroughly tested for nine months at Colorado Springs, Colorado, in 1899* – by bringing both locations together with a mutual relationship between them which transcended their spatial disjunction making their divergent locations into one singular, conjunctive location requiring no speed of light to delay the response at the receiver from the transmission of the sender.<sup>51</sup>

In other words, in my segregated analyses it becomes obvious, to the trained eye of the skilled artisan, that the appearance of reactive power and the disappearance of real power are simultaneous events without any causal relationship between them since they don't cancel each other – in other words, thermodynamics does not apply. They both occur at the same time preventing any accountability and making senseless any segregated analysis of their raw data as if to suggest that we are overlooking some other significant factor whose scope is, as yet, undetermined.

Yet, to appease those who are trained in traditional schools of thought, I perform these segregated analyses despite their futility in proving *conventional* thermodynamics is relevant for defining circuits involving spark gaps. It may be that our conventional understanding of thermodynamics is flawed for its shortsightedness in overlooking the significance of Mho's Law by overriding it with a superficial overuse of Ohm's Law along with its consequential overuse of the Conservation of Energy Law?

FIG. 77 is a photograph of the Ammann brothers standing in front of, and on either side of, their EV conversion which incorporates the use of their novel invention to which I owe my gratitude. Two red arrows have been inserted onto this photograph directly above the two

---

51 YouTube video → <https://is.gd/conjunctionofspaceandtime>

copper spheres seated within the headlight sockets where there used to be headlights before they were removed to make room for these spheres. I owe a debt of gratitude to “Tartaria Mud Flood” on FaceBook who posted this picture and has allowed me to use it within this application for provisional patent.

FIG. 78 is one of the two newspaper articles (that we know of), in which the photograph of FIG. 77 appears, scanned by a fellow who prefers to go by the EnergeticForum.com username of, Boguslaw, and who has kindly permitted me to use this newspaper clipping at my discretion.

If we intersperse a pair of capacitances in and among a large enough pair of inductances, then the back EMF of these two or more inductors will pull upon (resist) the absorption of these capacitors and convert them into reflectors rather than their conventional behavior acting as absorbers of energy.

Absorption of energy takes time. Reflection is immediate.

Thus, reflection results in an inversion of voltage and a standing wave of zero wattage since voltage folds back upon itself resulting in no net current when voltage polarization, thus, cancels itself. Any current we care to imagine is just that...imaginary current, also known as the square root of negative one times current. The voltage is, likewise, imaginary times the square root of negative one.

Under these circumstances, the girth of a piece of wire effectively collapses into an infinitely small diameter making the piece of wire unidimensional lacking any diameter, yet, retaining a length.

Thus, it may truly be said of this condition that it lacks current possessing merely resistance divided by the square of imaginary voltage...

$$\text{Conductance} = \text{Siemens} = \text{Mho} = \frac{\text{Resistance}}{(\sqrt{-1} \times \text{Voltage})^2} = \frac{\text{Resistance}}{-\text{Voltage}^2} = \text{Mho}'s \text{ Law} \quad \S 3.1a$$

This inversion, or self-cancellation, of voltage offers its own resistance to current in the format of an additional impedance added to whatever resistance already exists since it is predicated upon the reactance of capacitance reflecting back upon itself within the nurturing environment of inductive reactance which fosters and supports this phenomenon.

Thus, resistance increases with the negation of the square of voltage and, thus, conductance also increases (with this increase of resistance in the form of impedance) – under Mho's Law – despite the effective diameter of any piece of wire subjected to this circumstance will possess a zero diameter of girth. This will, effectively, increase the negation of power in the format of negative volts/amperes.

This is not a permanent condition. It must be continuously maintained or else it will revert back into Ohm's Law which specifies a completely different set of circumstances...

$$Power = Watts = \frac{Voltage^2}{Resistance} = Ohm ' s Law \quad \text{\$2.1a}$$

The production of power by a battery is non-reactive. It is not a byproduct of electrical reactance. Nor is the production of power by a rotary generator a purely reactive component since both a battery and a rotary generator require an external prime mover to authorize their potentiality as producers of power.

Yet, the reflectivity of a pair of capacitors acting within the context of a pair of inductors requires no prime mover of any significant motive force greater than whatever is already resident within the environment's ambient energy. In fact, Mho's Law encourages a low-voltage condition of high resistance in order to foster the increase of conductivity.

These pair of inductors provide their support analogous to a woman's womb in which the back EMF appearing within these inductors becomes inverted voltage with the help of a reflective pair of capacitors situated nearby and, thus, replaces back EMF with the simultaneous occurrence of inverted voltage inside of these inductors.

All of this occurs within the realm of complex numbers simultaneous to the occurrence of the real number calculations of Ohm's Law. Thus, it could be said of Mho's Law that it does not exist since it does not exist among the field of real numbers. It exists among the field of complex numbers. It is a concurrent existence to Ohm's Law effectively adding magic to what would otherwise be considered a straightforward scientific act visible to the untrained eye of the common perspective.

The electronic simulator figures all of this out by including these imaginary calculations involving the complex field of numbers among the real numbered calculations of Ohm's Law, but only if we construct circuits which encourages this phenomenon...



1. By keeping the input voltage low, and...
2. By fostering the buildup of impedance predicated upon reflective capacitance acting in conjunction with a large back EMF and discourage absorptive capacitance.

FIG. **80** is a solid-state version speculated to be a replication of Tesla's TriMetal Generator.

Aluminum discs are sandwiched in between each ring magnet.

On either side of each aluminum disc is a pancake coil whose orientation is selected on the basis of which pole of each ring magnet is inline with that coil.

Since magnetism follows the right-hand rule, if we were to look down from above – from the top of the stack downward towards the bottom of the stack in FIG. **80**, then a counter-clockwise wound pancake coil would be facing upwards towards our perspective in alignment with the north pole of the upper surface of the topmost ring magnet, followed by a pair of clockwise wound pancake coils in alignment with the south pole of the lower surface of the topmost ring magnet and the upper surface of the next ring magnet immediately beneath the topmost ring magnet situated on either side of the next aluminum disc beneath the topmost aluminum disc. Hence, the direction of winding for each pancake coil works with the right-hand rule of magnetic polarity in the vicinity of either the upper or lower surface of each ring magnet.

Each pair of pancake coils are serially connected together in an alternating fashion while among each pair, the central terminal of one coil connects with the outer terminal the other coil of that pair.

In other words...

One coil of each pair of CCW coils located on either side of a shared aluminum disc are connected together from the center terminal of one to the outer terminal of the other of each pair to create one extended straight line.

Likewise, one coil of each pair of CW coils located on either side of a shared aluminum disc are connected together from the center terminal of one to the outer terminal of the other of each pair to create one extended straight line.

But each CCW coil is connected either from its outer terminal to the outer terminal of the next CW coil, or else from the inner terminal of one coil to the inner terminal of the other coil in an alternating fashion.

This is a coiled version of a D/C battery with endless amp-hours available until the magnetism runs out.

If we prevent overheating, then their magnetism should last a long time.

Remember how I mentioned in the main text how current is a mathematical fiction born of our desire to simplify Ohm's Law by replacing voltage divided by resistance with a single variable called capital "I" which represents current? This subconsciously discourages us from pursuing the multiplicative reciprocal of Ohm's Law – Mho's Law – which contains a lower case "i" which represents the square root of negative one.

Current does not exist. It is a fabrication of the mind of man intended to represent a fictional movement of a mysterious prime mover along with its subsidiary smaller movers to affect a change in voltage across the vast emptiness of space. Yet, this fictional entity is not needed due to voltage already uses the dielectric medium of empty space to influence action at a distance without the need for anything else to make this action possible.

We know that no current travels through the dielectric of a capacitor. So, why do we need current in a wire to jump across the microscopic emptiness in between each atom of copper in a wire?

But the existential fiction of current helps us to visualize the movement of fictional abstractions. These fictionalized abstractions are the creations of the human mind which is always hungry for patterns. So, we create a fictional pattern of movement and call this fiction: "current."

Just as a wave of current does not exist as it travels around a football stadium created by individual members of the audience standing up and sitting down at precise intervals, likewise is the ripple of transverse current a fiction as the voltages of each copper atom changes over time creating this fictional pattern to arise inside of our mind.

So, a fictional current represents a change in voltage over time governed by resistance, or...

$$\frac{V}{R} = \frac{dV}{t} = \Delta \text{delta voltage per second} = (I) \text{Current}$$

§5

And the presence of resistance implies change (represented by the Greek letter, “Δ” – delta) over time.

Despite current's fictional existence, this fictional action at a distance known as: current, helps us conceptualize the changes in voltage occurring per unit of time.

Hence, the following figure may be useful if we don't take it too seriously! It is conveyed in the context of that other fictional creation of the human mind called, “alternating current” in which the reflection of voltage is a simultaneous affair occurring at right angles to the path taken by normal current.

So, if the path of fictionalized current travels down the length of a piece of wire, and the alternations of current occur, likewise, across this same length, then the path taken by the simultaneous occurrence of the capacitive reflection of voltage occurs across the diameter of a piece of wire resulting in a zero condition of current, no magnetism and, thus, a zero condition of watts.

Current occurs within the imaginary plane of complex numbers. Hence, we cannot measure it. Yet, we may infer it using the square root of negative one.

In FIG. **80**, the simultaneous alternation of imaginary current occurs under Mho's Law and does not alternate its direction. Instead, it travels in opposing directions at the same time effectively canceling itself creating a standing wave of voltage caught in between two states of:

1. Increased voltage and diminished resistance and diminished conductivity, along with...
2. A simultaneous decrease in voltage and an increase of resistance and an increase of conductivity during each half of an alternating cycle

Although the invention has been explained in relation to its preferred embodiment, it is to be understood that many other possible modifications and variations can be made without departing from the spirit and scope of the invention.